

2016-01-22

The Impacts of Bycatch from the Atlantic Tropical Tuna Purse Seine Fishery on Ecosystem Structure and Function

Francesca C. Forrestal
University of Miami, frescaff@gmail.com

Follow this and additional works at: http://scholarlyrepository.miami.edu/oa_dissertations

Recommended Citation

Forrestal, Francesca C., "The Impacts of Bycatch from the Atlantic Tropical Tuna Purse Seine Fishery on Ecosystem Structure and Function" (2016). *Open Access Dissertations*. Paper 1572.

This Open access is brought to you for free and open access by the Electronic Theses and Dissertations at Scholarly Repository. It has been accepted for inclusion in Open Access Dissertations by an authorized administrator of Scholarly Repository. For more information, please contact repository.library@miami.edu.

UNIVERSITY OF MIAMI

THE IMPACTS OF BYCATCH FROM THE ATLANTIC TROPICAL TUNA PURSE
SEINE FISHERY ON ECOSYSTEM STRUCTURE AND FUNCTION

By

Francesca Cassell Forrestal

A DISSERTATION

Submitted to the Faculty
of the University of Miami
in partial fulfillment of the requirements for
the degree of Doctor of Philosophy

Coral Gables, Florida

May 2016

©2016
Francesca Cassell Forrestal
All Rights Reserved

UNIVERSITY OF MIAMI

A dissertation submitted in partial fulfillment of
the requirements for the degree of
Doctor of Philosophy

THE IMPACTS OF BYCATCH FROM THE ATLANTIC TROPICAL TUNA PURSE
SEINE FISHERY ON ECOSYSTEM STRUCTURE AND FUNCTION

Francesca Cassell Forrestal

Approved:

David Die, Ph.D.
Research Associate Professor of
Marine Ecosystems and Society

Elizabeth Babcock, Ph.D.
Associate Professor of Marine
Biology and Ecology

Danielle McDonald, Ph.D.
Associate Professor of Marine
Biology and Ecology

Andrew Bakun, Ph.D.
Professor of Marine Biology
and Ecology

Victor Restrepo, Ph.D.
Vice President, Science
International Seafood Sustainability Foundation

Dean of the Graduate School

FORRESTAL, FRANCESCA CASSELL (Ph.D., Marine Biology and Fisheries)
The Impacts of Bycatch from the Atlantic Tropical (May 2016)
Tuna Fishery on Ecosystem Structure and Function

Abstract of a dissertation at the University of Miami.

Dissertation supervised by Professor David J. Die.
No. of pages in text. (208)

Global catches of tuna have increased steadily in the past several decades and this increase was largely driven by the switch to purse seine gears. Purse seine vessels target tropical tuna species in all the world's oceans and have two main modes of fishing, catching schools of tuna associated with a floating object (FAD sets) or schools of unassociated tunas (free sets). Both modes of fishing strategies have the potential to catch unintended species, termed bycatch, however larger rates of bycatch are seen from FAD sets. The total amounts of bycatch caught by both fishing strategies can be difficult to quantify without 100% coverage of onboard observers recording bycatch. This dissertation presents methods to determine total bycatch from unobserved sets using variations of the stratified ratio estimator method. Bycatch is retained onboard the fishing vessel or discarded at sea, with the aim to discard the bycatch species alive, however there is the potential for high levels of post-release mortality. Impaired reflexes of species that are discarded at sea were measured and were a significant predictor of delayed mortality. Proportions of impaired reflexes and delayed mortality were paired with physiological indicators of stress in teleost species.

The data obtained from the first part of the dissertation was used to build an Ecopath model of the Gulf of Guinea to understand the total impacts removals of the targeted tuna and bycatch species have on the ecosystem. This model was calibrated using available time series for the Gulf of Guinea. The fitted model was then used to build several scenarios with varying both bycatch removals and purse seine fishing effort. The largest changes to the ecosystem resulted from changes to the purse seine fishing effort, rather than the treatment of the bycatch.

Acknowledgements

This work would not have possible without the support of my advisor, David Die, who encouraged me from the very start of my career as a master's student. I also thank my committee for their support and encouragement, Elizabeth Babcock, Andrew Bakun, Danielle McDonald and Victor Restrepo.

I thank my funding sources: the Cooperative Institute for Marine and Atmospheric Science (CIMAS), the International Seafood Sustainability Foundation (ISSF), the Mary Roche Fellowship and the Harry D. Vernon Scholarship.

I thank the UM Experimental Hatchery staff for their support of the work presented in Chapter 3 and the Cape Eleuthera Institute researchers for the work presented in Chapter 4. I also thank Christopher Moore, Alyson Oriold, Rebecca Pelofsky, Dominique Lazarre, Michelle Sculley, Ron Hoenig, Petra Szekeres, Aaron Schultz and Zack Zuckerman. I thank Frederic Menard and Marta Coll for their input for the work presented in Chapters 5 and 6. I also thank the European Union Tuna Observer program, for collecting the observer data used in this dissertation, I thank Pierre Chavance, Hilario Murua and Alicia Delgado de Molina for compiling and providing the data.

I thank my mother, Kit Forrestal, for supporting me from the instant I decided I was going to be a marine biologist in the 3rd grade. I thank my in-laws, Ann Burke and Dale Enochs, for cheering me on every step of the way. Last but not least, I thank my husband, Ian Enochs, for constantly believing in me and pushing me to keep going.

Table of Contents

List of Figures	vi
List of Tables	xi
Chapter 1: Introduction	1
Chapter 2: Estimates of the total bycatch from the EU tuna purse seine fleet in the eastern tropical Atlantic.....	9
Overview	9
Methods	15
Data Preparation	15
Ratio Estimator	19
Unobserved Strata	20
Bayesian Model	21
Delta Model	23
Results	24
Ratio Estimators	26
Delta Model	32
Discussion.....	38
Estimation Methods.....	38
Patterns in Bycatch Amounts and Composition.....	42
Conclusion.....	46
Chapter 3: Reflex impairment as a measure of delayed mortality in a tuna purse-seine bycatch species, grey triggerfish (<i>Balistes capriscus</i>)	48
Overview	48
Methods	51
Baseline Tests	53
Stress Tests	54
Statistical Analysis	55
Results	57
Stress Tests	57
Bayesian Model	61
Discussion:	63
Stressors.....	63
Model Uses	68
Conclusions	69
Chapter 4: Impaired reflexes as measure of delayed mortality in recreationally caught yellowtail snapper (<i>Ocyurus chrysurus</i>).....	72
Overview	72
Methods	74
Collection and Holding.....	74
Reflex and Stress Testing	76
Blood Sampling	77

Laboratory Testing	78
Statistical Analysis	78
Results	79
Reflex and Stress Testing	79
i-STAT Measurements	85
i-Stat Validation.....	87
Discussion.....	89
Conclusions	95
Chapter 5: Ecopath model examining the effects of the tuna purse-seine fishery on the ecosystem of the Gulf of Guinea	96
Overview	96
Methods	97
Ecopath Approach	97
Model Structure and Parameterization	98
Functional Groups	100
Fisheries.....	127
Discards	128
Discard Mortality Rate	129
Model Analysis.....	130
Results	132
Data Inputs.....	132
Trophic Flows and Ecosystem Indicators.....	133
Discussion.....	144
Conclusions	149
Chapter 6 – Simulated ecological effects of the tuna purse seine fishery on the Gulf of Guinea	150
Overview	150
Methods	152
Ecosim Approach	152
Biomass Levels.....	153
Time Series	154
Scenarios.....	157
Ecological Indicators	158
Results	161
Scenarios: Biomass and Yield	164
Scenarios: Ecological Indicators	167
Discussion.....	176
Changes to Biomass of Functional Groups	176
Changes to Ecosystem.....	181
Conclusions	184
Chapter 7: Conclusion	185
References	188

List of Figures

Figure 1. Global catches of the five major tuna species: YFT = yellowfin, SKJ = skipjack, BFT = bluefin tuna, BET = bigeye tuna and ALB = albacore. <i>Source: ISSF Status of the World Fisheries for Tuna - November 2015</i>	1
Figure 2. Global catches of the five major tuna species: YFT = yellowfin, SKJ = skipjack, BFT = bluefin tuna, BET = bigeye tuna and ALB = albacore (top panel) and global catches by gear type (bottom panel). <i>Source: ISSF Status of the World Fisheries for Tuna - November 2015</i>	2
Figure 3. Total observed bycatch amounts for object associated sets (top panel) and free sets (bottom panel) from 2003-2013 from the EU tuna observer programs. Functional groups are defined in table 2.	13
Figure 4. Observer coverage compared to total observed catches (observed bycatch and observed catch in mt). Observer coverage calculated from observed sets to unobserved sets in European Observer program (Damiano <i>et al.</i> , 2014).....	15
Figure 5. Location of both FAD and free observed sets from 2003-2013.	17
Figure 6. ICCAT Task II totals for all reported landings from EU purse seine fleet in the eastern tropical Atlantic.....	17
Figure 7. Code for Bayesian model.....	23
Figure 8. Linear regression model on stratified observed totals for FAD sets (top panel) and free sets (bottom panel) with 95% confidence interval in grey shading.....	30
Figure 9. Bycatch estimates for ofeach functional group using the three estimation methods, stratified using ratios for neighboring strata, collapsed and Bayesian.. Error bars represent one standard deviation of the estimated total bycatch.....	35
Figure 10. Composition of bycatch for FAD sets (left panel) and free sets (right panel). 36	
Figure 11. Deviance of Bayesian model 1 and sample of predicted ratio estimator posterior distributions.	36
Figure 12. Diagnostic plots for FAD BPUE binomial and GLM models (top panel, left and right) and free BPUE binomial and GLM models (bottom panel, left and right).	37
Figure 13. Standardized BPUE with nominal BPUE and 95% confidence intervals for FAD sets (left panel) and free sets (right panel).....	38

Figure 14. Size distribution of collected triggerfish	52
Figure 15. Dorsal spine reflex testing under restraint	54
Figure 16. Mean proportion of impaired reflexes for all groups after air exposures. Error bars are standard errors of the mean. Data points are mean proportion for each group after air exposure. Letters represent significant difference in impaired reflexes after air exposure.	59
Figure 17. Proportional contribution of impairment to total RAMP score from each tested reflex for all groups and all air exposures.	60
Figure 18. Relationship between air exposure (m) and impaired reflexes with 95% confidence band.	61
Figure 19. Relationship between impaired reflexes and delayed mortality.	62
Figure 20. Trace and posterior distribution of full model (beta[2] (Air) and beta[3] (RAMP)).....	70
Figure 21. Trace and posterior distribution of model using impaired reflexes (beta[2] (RAMP)).....	71
Figure 22. Distribution of size classes (average length 28.8 cm, median 29 cm). Black line signifies minimum size allowed in US territorial waters (30 cm).....	75
Figure 23. Proportional contribution of each impaired reflex.	80
Figure 24. Linear regression model fitted to air exposure (minutes) and impaired reflexes (proportion). Points are individual fish impaired reflex scores at given air exposures. Red dashed line represents air exposure at which 25% of reflexes become impaired. Gray area around fitted line represents 95% confidence interval (p=0.00013, n=30)	82
Figure 25. Impaired reflexes predicted by air exposure fitted to sigmoidal curve and 95% confidence interval.	83
Figure 26. Results of generalized linear model (binomial with logit link) on individual fish's reflex scores (RAMP scores) and delayed mortality. Lethal doses of impaired reflexes are noted with dashed lines (LD25, LD50 and LD75). Gray area around fitted line represents 95% confidence interval (p=0.063, n=30).	84
Figure 27. Proportion of delayed mortality predicted by impaired reflexes fitted to sigmoidal curve and 95% confidence interval. Dashed blue line point at which impaired reflexes result in 50% delayed mortality.	84

Figure 28. Results of Pearson Correlation between air exposure, impaired reflex score (RAMP), and delayed mortality. Variables that are not significant ($p>0.05$) are crossed out.	85
Figure 29. Linear regression model fitted to pH levels and impaired reflexes (RAMP) and 95% confidence interval (gray area).....	86
Figure 30. Linear regression model of glucose concentrations measured with assay and by i-STAT CG8+. Gray area around fitted line represents 95% confidence interval ...	88
Figure 31. Linear regression model of lactate concentrations measured with assay and by i-STAT CG8+. Gray area around fitted line represents 95% confidence interval	89
Figure 32. Modified map of FAO fishing areas with PICOLO model area outlined in yellow and the Gulf of Guinea model area outlined in brown.	99
Figure 33. Multi-stanza routine within Ecopath to estimate parameters of non-leading stanza (juvenile yellowfin).	112
Figure 34. Size composition of catch of yellowfin tuna by gear group. Red arrow represents size at maturity.	113
Figure 35. Multi-stanza routine within Ecopath to estimate parameters of non-leading stanza (juvenile bigeye).	115
Figure 36. Size composition of catch of bigeye tuna by gear group. Red arrow represents size at maturity.	116
Figure 37. Figure from original PICOLO model calculating biomass of mesopelagics due to diel vertical migration Source: <i>Schultz, 2001</i>	124
Figure 38. Trophic flow diagram showing the connections between the functional groups of the Gulf of Guinea model. Colored lines denote the relative proportion of each predator's diet.....	137
Figure 39. Lindeman Spine diagram quantifying the trophic flows between each trophic level, legend showing destination of each component of biomass. Biomass flows in $t/km^2/yr$	138
Figure 40. Graphical results of the Mixed Trophic Impact analysis. Impacting groups are on the vertical axis while impacted groups are on the horizontal axis. The size and color of the ovals represents the magnitude and nature of the impacts between functional groups.....	139

Figure 41. Total MTI results of impacting functional groups on the remaining groups.	140
Figure 42. Regression of the longevity of each functional group against their respective trophic levels used to assess thermodynamic stability.	141
Figure 43. Regression of the trophic levels of each functional group against their respiration to assimilation ratio used to assess thermodynamic stability.	142
Figure 44. Partitioning of consumption of production in the system for all functional groups (A) and the consumption of the production by fished functional groups (consumption \geq 2%).	143
Figure 45. Model outputs fitted to time series data. Value within parentheses are the sum of squares. Time series run from 1974-2009.	163
Figure 46. Annual estimates of three ecosystem indicators from 1974-2009. Dashed line at 1991.	165
Figure 47. Percent changes in biomass across the five scenarios for discarded bycatch model (results same for retained bycatch model). Top panel shows functional groups targeted by free and FAD purse seine fleets, middle panel shows groups caught as bycatch and bottom panel shows biomass changes in lower trophic level forage fish. D1-D5 represent different discard scenarios.	169
Figure 48. Biomass changes in $t/km^2/yr$ for targeted tuna species. Baseline has constant fishing pressure, D1: 50% increase in both FAD and free school fishing pressure, D1: 50% increase in FAD fishing pressure, no change in free, D3: no change in FAD, 50% increase in free school fishing pressure, D4: 25% reduction in both FAD and free school, D5: 25% decrease in FAD fishing pressure, free school pressure remained constant. Models run under discarded bycatch model, patterns in biomass changes same in retained bycatch model.	171
Figure 49. Biomass changes in $t/km^2/yr$ for species caught as bycatch. Baseline has constant fishing pressure, D1: 50% increase in both FAD and free school fishing pressure, D1: 50% increase in FAD fishing pressure, no change in free, D3: no change in FAD, 50% increase in free school fishing pressure, D4: 25% reduction in both FAD and free school, D5: 25% decrease in FAD fishing pressure, free school pressure remained constant. Models run under discarded bycatch model, patterns in biomass changes same in retained bycatch model.	172

Figure 50. Yield changes in t/km²/yr for target species in all 5 scenarios. Baseline has constant fishing pressure, D1: 50% increase in both FAD and free school fishing pressure, D2: 50% increase in FAD fishing pressure, no change in free, D3: no change in FAD, 50% increase in free school fishing pressure, D4: 25% reduction in both FAD and free school, D5: 25% decrease in FAD fishing pressure, free school pressure remained constant..... 173

Figure 51. Yield changes in t/km²/yr for bycatch species in all 5 scenarios. Baseline has constant fishing pressure, D1: 50% increase in both FAD and free school fishing pressure, D2: 50% increase in FAD fishing pressure, no change in free, D3: no change in FAD, 50% increase in free school fishing pressure, D4: 25% reduction in both FAD and free school, D5: 25% decrease in FAD fishing pressure, free school pressure remained constant..... 174

List of Tables

Table 1. Overview of observer data for the three institutions.	15
Table 2. List of species included in each component of bycatch.	18
Table 3. Totals of all bycatch for FAD sets for three estimation methods.....	24
Table 4. Totals of all bycatch for free sets for three estimation methods.....	25
Table 5. Raw totals (mt) and averages (mt) of bycatch, discard and catch of each functional group across all observed sets from 2003-2013.	26
Table 6. The fate of bycatch functional groups expressed as a percentage of the total number of individuals caught (Total) over the period 2003-2013.	28
Table 7. Outputs of linear models used to identify significant predictor variables for ratio estimates.	29
Table 8 Comparisons between Bayesian model 1 and previously published total bycatch estimates.	44
Table 9. Mean (SE) proportions of individual reflex impairment for each group and air exposure (n).....	58
Table 10. Mean (SE) proportions of total reflex impairment and mortality for each group and air exposure (n).	58
Table 11. Results of ANOVA between group reflex impairment.....	59
Table 12. Results of ANOVA between group mortality.....	59
Table 13. Results of ANOVA between reflex impairments at air exposures of pooled groups.	60
Table 14. Results of ANOVA between mortality at different impaired reflexes of pooled groups.....	60
Table 15. Bayesian model results with mean effect of parameters on mortality and credible intervals. Rhat value of 1.00 shows model has converged and n.eff is the effective sample size for each parameter, which should be more than ~500 (Lunn ref).	62
Table 16. Model selection results, correct shows correctly predicted outcomes. Model with sole variable of RAMP score selected as best model.	62

Table 17. Numbers of fish within each group and total numbers of fish tested at each exposure.....	77
Table 18. Model results of air exposure on impaired reflexes in individual fish and group averages.	81
Table 19. Model results of proportion of impaired reflexes (RAMP) on delayed mortality in individual fish and group averages.....	83
Table 20. Summary of results from linear regression model predicting impaired reflexes using i-STAT parameters and air exposure. Model 1 is the complete model and Model 2 is preferred by the AIC.....	86
Table 21. Summary of results from linear regression model predicting delayed mortality using i-STAT parameters, impaired reflexes and air exposure.	87
Table 22. Results of binomial GLM predicting mortality given air exposure, impaired reflexes or blood sampling.	87
Table 23. Species composition of functional groups with more than one species.	102
Table 24. Values used to calculate P/B and Q/B for the seabird functional group.	103
Table 25. Life history parameters, weighting factors (WF) and source for each species of sharks in functional group Sharks.	106
Table 26. Biomass, weighting factor (WF) and calculated Q/B values for each species of marine mammals in the Marine Mammal functional group. Calculated Q/B obtained from Vasconcellos and Watson 2004.	108
Table 27. Input parameters and final calculations for the Billfish functional group.....	111
Table 28. Natural mortality (M) and fishing mortality (F) used for initial instantaneous mortality (Z) and P/B for the tuna functional groups.	114
Table 29. Life history and input parameters for species within the Scombridae functional group.....	118
Table 30. Life history and input parameters for species within the Carangid functional group.....	119
Table 31. Life history parameters used to estimate M, P/B and Q/B for Coryphaena. ...	120

Table 32. Life history parameters used to estimate M, F, P/B and Q/B for the Balistidae functional group.....	121
Table 33. Life history parameters used to estimate M, F, P/B and Q/B for species contained within Epipelagic I.....	122
Table 34. Life history and input parameters for species within the Epipelagic II functional group.....	122
Table 35. Life history parameters used to estimate P/B and Q/B for small epipelagics	123
Table 36. Fisheries and reported landings ($t\ km^{-2}\ yr^{-1}$) in the model area.....	127
Table 37. Discards ($t\ km^{-2}\ yr^{-1}$) by fleet and total discards for each functional group...	128
Table 38. Discard mortality rate for functional groups caught as discards.....	129
Table 39. Final input parameters for Gulf of Guinea model. Values in bold represent parameters estimated by Ecopath.....	134
Table 40. Results of Monte Carlo trials using confidence values derived from Pedigree Index for the biomass, P/B and Q/B input parameters.....	135
Table 41. Diet composition matrix with prey (row) and predator (column) with import amount.....	136
Table 42. Summary statistics and indices of the Gulf of Guinea and the comparison of statistics from previous PICOLO model.....	144
Table 43. Final model fits of all functional group's vulnerabilites adjusted and only the groups with time series (TS) adjusted.....	161
Table 44. Changes (%) to yield ($t/km^2/yr$) for target groups and bycatch groups. Groups shaded for changes above 4%. D1-D5 represent different discard scenarios.....	169
Table 45. Percent change in biomass of functional groups from 2009-2059 for the two models (discarded or retained bycatch) and 5 scenarios. Scenarios D4, D5, R4, R5 represent a reduction in purse seine catches. Changes are shaded (blue: +; orange:).	170
Table 46. All measured system statistics for all scenarios and models at the completion of the simulation (Year 2059). D1-D5 represent different discard scenarios R1-R5 represent different bycatch retention scenarios.....	175

Table 47. Trends in system statistics relative to baseline scenario.D1-D5 represent different discard scenarios R1-R5 represent different bycatch retention scenarios.. Negative trends in orange, positive in blue. 176

Chapter 1: Introduction

Catches from the global tuna fishery provide an important food source and are an economically valuable commodity. Tuna catches in 2012 accounted for 9% of the total marine capture fisheries, with skipjack and yellowfin tunas among the 10 most productive species caught (FAO, 2014). The annual catch of tuna has increased from 300,000 metric tons in the 1950's to 4.7 million metric tons in 2013, peaking at 9.5 million metric tons in 2003 (Majkowski, 2007). This increase in fishing has largely been the result of a shift from hook and line fisheries to more efficient purse seine vessels and advances in gear technology (Miyabe and Nakano, 2004). The five major commercial species of tuna (by catch tonnage) are skipjack (*Katsuwonus pelamis*, 57%), yellowfin (*Thunnus albacares*, 27%), bigeye (*T. obesus*, 9%), albacore (*T. alalunga*, 6%) and bluefin (common name for three species: *T. maccoyii*, *T. orientalis*, and *T. thynnus*, 1%).

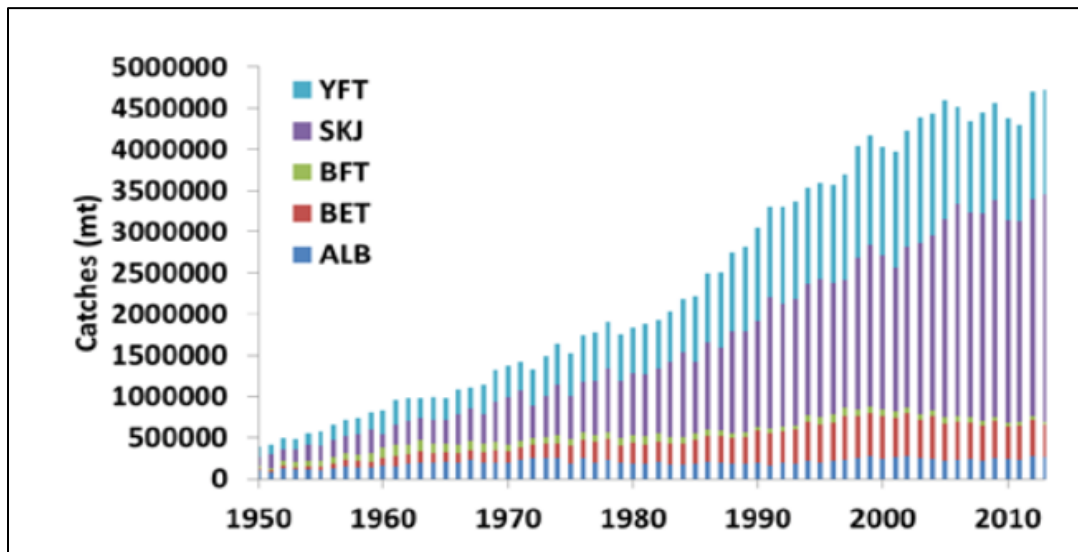

Figure 1. Global catches of the five major tuna species: YFT = yellowfin, SKJ = skipjack, BFT = bluefin tuna, BET = bigeye tuna and ALB = albacore. *Source: ISSF Status of the World Fisheries for Tuna - November 2015.*

Tuna are classed as highly migratory species, meaning that catches occur either within several countries exclusive economic zones (EEZ) or the high seas, where 40% of tuna are caught (Allen, et al, 2010). The major tuna species are split into 23 stocks and managed by five tuna regional fishery management organizations (RFMOs). Tuna stocks in the Atlantic, the focus of this dissertation, have been managed by the International Commission for the Conservation of Atlantic Tunas (ICCAT) since 1969. The major fishing gears targeting these stocks are purse seining, which accounts for 64% of the global catch; longline with 12%, pole-and-line, termed baitboat in the Atlantic, with 10%, and gillnets with 4% of the tuna catch. Other miscellaneous gears account for the remaining 10% of catches (ISSF, 2015). Each method of fishing has its unique set of bycatch issues; this dissertation focused on bycatch issues of the purse seine fishery.

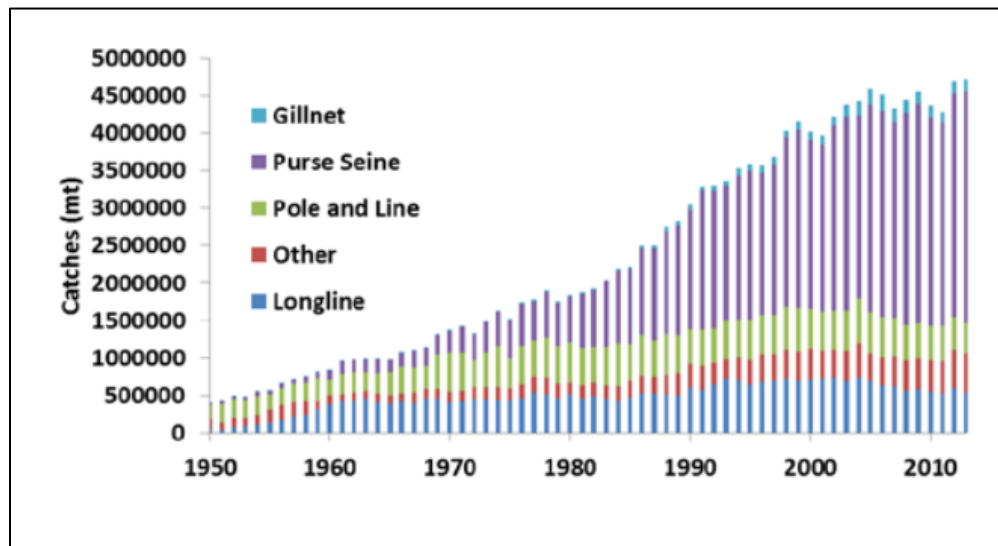

Figure 2. Global catches of the five major tuna species: YFT = yellowfin, SKJ = skipjack, BFT = bluefin tuna, BET = bigeye tuna and ALB = albacore (top panel) and global catches by gear type (bottom panel). *Source: ISSF Status of the World Fisheries for Tuna - November 2015.*

Tuna purse seiners operate worldwide in tropical waters, with the largest catches coming from the Western and Central Pacific followed by the Indian Ocean. Due to the recent piracy problem in the eastern Indian Ocean, some fishing fleets have transferred their efforts to the Atlantic Ocean (Chassot *et al.*, 2010), which yields roughly 10% of the global tuna catch. The eastern tropical Atlantic, in particular the northern Gulf of Guinea, is the main purse seine fishing ground in the Atlantic Ocean and the fleets have shifted to predominately targeting FAD (fish aggregating device) associated schools of tuna since 1991 (Menard *et al.*, 2000). Commercial purse seine vessels range from 40 to 115 m in length with a fish hold capacity of up 3,000 mt. Once a school of tuna has been located, the purse seiner deploys a small workboat that tows the seine net around the school of fish. The net is brought back to main vessel and the net is tightened, “pursed”, around the school. Once the net is fully pursed, the fish are brought onboard via a brailer or large scoop. Large bycatch animals are generally released from the deck while other bycatch is sorted below and released from a chute, depending upon the construction of the vessel.

Historically, purse seine vessels have targeted large schools of either skipjack or yellowfin tunas. These schools are comprised of assemblages of a single species of tuna, within the same general size class. After the 1980’s effort has shifted from these free tuna schools to object-associated schools. These objects range from natural logs, large dead animals, such as whales, under-water seamounts to man-made floating objects. In the Eastern Pacific Ocean, yellowfin are frequently associated with dolphins, so that purse seine vessels often set their nets around dolphin pods, which prompted the call for dolphin safe tuna. Tunas form schools around both whales and whale sharks in all oceans; while the dolphin associated schools of yellowfin tuna just occur in the eastern

Pacific Ocean. Sets made on whales are classified as free schools while sets on whale sharks are classified as object or FAD associated schools due to the composition of the catch for each respective type of set. However, this classification depends on the ocean and the flag of the fishing vessel (Gaertner *et al.*, 2002; Scott *et al.*, 1992).

Schools of tuna associated with floating objects caught by purse seiners are termed object or FAD sets, and fall into two main categories, anchored FADs and drifting FADs. FADs are typically constructed of floating rafts with netting or some other type of below-water structure. FADs are often equipped with satellite buoys, to allowing their location to be known by the fishing vessel. The exact number of FADs that are in operation or have been abandoned is unknown; however recent estimates from PEW set the annual number of individual FAD deployments in the Atlantic around 17,000 (PEW, 2015). Concern has focused on these man-made objects due to the wide variety of marine life, including juvenile tunas, associated with them that are incidentally caught by purse seine vessels. Additionally, proliferation of man-made FADs in areas lacking natural floating objects could cause changes in behavior, including natural migration patterns (Dempster and Taquet, 2004). These changes in fish behavior could result in FADs acting as an “ecological trap” and lead to modifications in diet, prey switching and poorer feeding conditions (Dagorn *et al.*, 2010; Essington *et al.*, 2002). There is evidence that tunas associated with drifting FADs are of smaller size and are more likely to have empty stomachs than tunas associated with anchored FADs (Jaquemet *et al.*, 2011; Marsac *et al.*, 2000), however there is still uncertainty if FADs do act as a true ecological trap (Dagorn and Menard, *in prep*).

Tunas, especially small tunas, aggregate under floating objects and become less active, making them easier to catch (Menard *et al.*, 2000). Association of the various fish species with FADs has been well documented; however, accepted theories for these associations are few (Freon and Dagorn, 2000). The general theory for the association is that the pelagic environment is an extremely uniform one so any physical anomaly will attract attention; however, this does not explain why fish remain with the physical anomaly for days to weeks at a time. Due to logistical constraints, the majority of studies on the behavior of fish species around FADs have been on anchored FADs. Initially, it was thought the size of the FAD would play a role in the size of the assemblage beneath it; however large schools of tuna have been found under floating palm fronds, although in general, medium size FADs are more attractive than small or larger sized FADs (Hall *et al.*, 2000).

The two main hypotheses for the aggregating behavior, discussed by Freon and Dagorn, are the meeting point hypothesis and indicator log hypothesis. Several other hypotheses have been proposed for tuna aggregations, however the authors argued the supporting evidence for these alternate hypotheses was weak. The indicator log hypothesis is based on logs originating from productive areas, river mouths and swamps, and the surrounding productive water remaining entrained around the floating object. Logs can also indicate a productive frontal zone, that can make up a triad *sensu* (Bakun, 2006). The meeting point hypothesis posits that schooling species use FADs to increase encounter rates, however it relies on the assumption that these species are able to detect

floating objects from further away than they can detect schools of fish. The evolutionary basis for the meeting point hypothesis is similar to the evolutionary reasons for schooling in general; *i.e.*, protection from predation and increased prey encounter rate.

Species in addition to tunas found beneath FADs include sharks, billfish (Istiophoridae), rainbow runners (*Elagitis bipinnulata*), dolphinfish (*Coryphaena*), wahoo (*Ananthocybium*), triggerfish (Balistidae *spp.*) and barracuda (*Sphyraenidae*). Both predator and prey species have been found around FADs, with some predation activity observed, however the presence of a predator species is not always explained by the presence of its prey species (Freon and Dagorn, 2000). While schools of predators and prey items are often found together at FADs there are few published reports of predation being observed (Potier and Sadhotomoto, 1995). However, in the case of large tuna schools, FADs do not appear to act as a source of prey items. Stomach content analysis conducted on schools of tuna associated with FADs demonstrate the major prey items are mesopelagic fish species (Ménard and Marchal, 2003; M. Potier *et al.*, 2007).

Association with floating objects is a widespread behavior across species and it has been theorized there must exist a significant adaptive reason for this association (Dempster and Taquet, 2004). There are two types of processes that could explain the emergence of the associative behavior, intergenerational transmission of this behavior or natural selection (Freon and Dagorn, 2000). However, if the first were to hold true, older individuals would be found in great numbers associated with FADs and this has not been observed. From a natural selection standpoint, the drive to find schools of conspecifics

could support the meeting point hypothesis (Freon and Dagorn, 2000). This of course depends on the ability of tunas to locate FADs from a further distance away than they can locate other schools of tuna.

The stages of colonization of the FAD by fish species have been examined by various studies and it appears to be fairly rapid, under a few days (Yu, 1992).

Recruitment to the FAD can also be ongoing as purse seiners will remain with a FAD for several days with catches remaining constant (Freon and Dagorn, 2000). The process of locating drifting FADs by fish has been thought to be primarily visual, however sound and odors of fouling organisms could also play a role. Fish of the genera *Seriola* and *Corphaeyna* could locate drifting FADs from several hundreds of meters away, well outside visual range (Dempster and Kingsford, 2003). Other hypotheses include low frequency sounds produced by both the FAD structure and first colonizers of the FAD. Yellowfin tuna are able to orient towards anchored FADs up to 10 km away and have used them as markers in migratory pathways. Their method of detection for returning to anchored FADs appears to be bio-magnetic in nature as yellowfin possess cranial biogenic magnetite and potentially can orient themselves using the earth's magnetic field pattern. However, this method would not function for locating drifting FADs (Dempster and Kingsford, 2003).

While the underlying mechanisms of this associative behavior are poorly understood and need to be further studied, the impacts of the fishery that exploits this behavior can be investigated. Large-scale questions on the impacts of bycatch were developed by Hall (1996). What happens to the community if, due to selectivity, a fishery reduces or increases the average size of individuals? How does the selectivity of the

fishery differ from selectivity of predation? How is the spatial distribution of prey species modified? And the major question this dissertation tries to specifically address: how does the composition and amount of bycatch affect the stability and productivity of the ecosystem?

The bycatch data for the EU purse-seine fishery is available from the on-going observer program, which this paper uses as well as a handful of research cruises and their associated publications. Previous bycatch estimates were obtained through specialized research cruises, such as the EU bigeye observer program, which focused on bigeye tuna in the Gulf of Guinea, and ran from 1997-1999 (Fonteneau *et al.*, 2000a). These longer-term studies in both the Atlantic and Indian Oceans have noted that the fishing mode substantially effects both species composition and magnitude of the bycatch, with FAD sets leading to higher levels of bycatch (Ariz, et al 1999, Hallier and Parajua, 1999 and Fonteneau, 2000).

This dissertation is comprised of five data chapters. Chapter 2 estimates the total bycatch removed by the EU purse seine fleet using the EU tuna observer database and several estimation methods based on the ratio estimation method. The post-release mortality of discarded teleosts was assessed in Chapter 3 and Chapter 4. Using data from Chapter 2 and Chapter 3, an Ecopath model of the Gulf of Guinea was developed in chapter 5. Finally, Chapter 6 examines overall trends in biomass, catch and ecological indicators of the Gulf of Guinea with an Ecosim model.

Chapter 2: Estimates of the total bycatch from the EU tuna purse seine fleet in the eastern tropical Atlantic

Overview

The impacts of fishing activity are not solely limited to the stock that is being targeted; they can be observed throughout the ecosystem in which a fishery operates. The shift towards an ecosystem approach to fishery management (EAFM), takes into consideration all impacts from fishing including changes to community structure and diversity, as well impacts to the physical environment (Hobday *et al.*, 2011; Levin *et al.*, 2009; Link *et al.*, 2002; Pikitch *et al.*, 2004). The overall goal of the EAFM is to maintain a healthy and functioning ecosystem in which fisheries can be supported; one of the tenets of this approach is a reduction in the amounts of fish and marine mammals inadvertently captured during the fishing operation, termed bycatch (Gerrodette *et al.*, 2012; Hall and Mainprize, 2004). However, reliable, quantitative estimates of the amount of bycatch removed by different fishing fleets can be difficult to obtain; due in part to fisheries operating far from shore and for extended periods of time (Amande *et al.*, 2010; Davies *et al.*, 2009). Without knowledge on the current levels of bycatch, it is difficult to assess the overall effects of bycatch removal and put in place regulatory measures when these are needed (Lewison *et al.*, 2011). The impacts of fishing activity are not solely limited to the stock that is being targeted; they can be observed throughout the ecosystem in which a fishery operates. The shift towards an ecosystem approach to fishery management (EAFM), takes into consideration all impacts from fishing including changes to community structure and diversity, as well impacts to the physical environment (Hobday *et al.*, 2011; Levin *et al.*, 2009; Link *et al.*, 2002; Pikitch *et al.*, 2004).

The overall goal of the EAFM is maintain a healthy and functioning ecosystem in which fisheries can be supported; one of the tenets of this approach is a reduction in the amounts of fish and marine mammals inadvertently captured during the fishing operation, termed bycatch (Gerrodette *et al.*, 2012; Hall and Mainprize, 2004). However, reliable, quantitative estimates of the amount of bycatch removed by different fishing fleets can be difficult to obtain; due in part to fisheries operating far from shore and for extended periods of time (Amande *et al.*, 2010; Davies *et al.*, 2009). Without knowledge on the current levels of bycatch, it is difficult to assess the overall problem of bycatch removal and put in place regulatory measures when these are needed (Lewison *et al.*, 2011).

Bycatch removals are not assessed as part of the formal, single-species stock assessments for tuna and historically data on bycatch was rarely collected (Depestele *et al.*, 2011). Monitoring of bycatch removals is part of the observer programs of different countries as mandated by the tuna Regional Fishery Management Organizations (tRFMOs), however these programs are expensive and logistically difficult to implement. With the exception of 100% coverage onboard tuna purse seine vessels in the eastern tropical Pacific, coverage rates of vessel trips can be quite low, making a well-balanced sampling regime difficult to achieve (Amande *et al.*, 2010; Babcock and Pikitch, 2003; Hall and Roman, 2013). To limit costs and improve precision, several countries and regions rely on stratified sampling of fishing fleets, sampling proportional to vessel size,

and ratio estimators based on landings (Hall and Roman, 2013; M.-J. Rochet and Trenkel, 2005). All of these methods rely on implicit assumptions about the factors that influence bycatch variability.

Bycatch amounts and composition are dependent on the fishing mode and gear used and can also be influenced by spatio-temporal variables. Compounding influences can include technical, economic, environmental and social factors unique to each fleet (Amandè *et al.*, 2010; Depestele *et al.*, 2011; M. Rochet and Trenkel, 2005). In general, tuna purse-seine bycatch species composition is similar across oceans, with the notable differences in bycatch resulting from sets made on free or unassociated schools of tuna and those made on schools of tuna associated with natural floating objects and drifting fish aggregating devices (dFADs). The exception to this are dolphin associated sets in the eastern Pacific Ocean (Archer *et al.*, 2002). The bycatch from sets made on dFADS is more numerous and more diverse than the bycatch from sets made on free schools; this has been observed across ocean basins and purse-seine fleets (Amandè *et al.*, 2010; Fonteneau *et al.*, 2013; Gaertner *et al.*, 2002; Hallier and Gaertner, 2008a). The bycatch caught within both FAD and free sets fall into the categories of tunas, bony fish (excluding targeted scombrids and billfish), billfish, elasmobranchs and sea turtles. Abundances of these species within the bycatch can vary seasonally and by area.

Bias and precision of bycatch estimates will be affected by biological, environmental, and economical factors (Amandè *et al.*, 2012). The use of stratified sampling, either designed a priori or post hoc, relies on the assumption that bycatch composition and amounts are affected by spatio-temporal variations, possibly including environmental effects (M.-J. Rochet and Trenkel, 2005). In the case of the eastern

Atlantic, true random stratified sampling is not feasible as observers are limited to larger vessels and each country designs and manages its own at-sea observer program. ICCAT recommends (ICCAT Rec. 10-10) a minimum observer sampling coverage of 5% for purse seine, longline and baitboat fleets targeting tropical tunas (ICCAT 2010) and in recent years it has achieved this level (Figure 4). It needs to be noted that ICCAT has mandated 100% observer coverage in the seasonal closure areas where FAD fishing is prohibited (ICCAT Rec. 11-10). Previous studies have estimated that observer, or sampling coverage, would need to be a minimum of 20% (Babcock and Pikitch, 2003).

Discussions on the importance of bycatch are centered on the most vulnerable species to fishing pressure, those with low fecundity, long lifespans and late maturation; specifically elasmobranchs, sea turtles, and marine mammals (Monin Justin Amandè *et al.*, 2011; Carranza *et al.*, 2006; Coelho *et al.*, 2011; Dulvy *et al.*, 2008; Gaertner *et al.*, 2002; Gardner *et al.*, 2008; Hall, 1995). Because of their life history, these large charismatic species are vulnerable to fishing pressure and any catch, incidental or otherwise, often exceeds the fishing pressure the species can withstand (Burgess *et al.*, 2005; Couturier *et al.*, 2012; Dayton *et al.*, 1995). The majority of purse seine bycatch, in terms of weight and numbers of individuals incidentally caught, is comprised of small teleosts, members of the Scombridae, Balistidae and Carangidae families (Figure 3). The composition of teleost bycatch species varies by ocean and region, however, *Auxis spp.*, wahoo (*Acanthocybium solandri*), mahi-mahi (*Coryphaena spp.*) and triggerfish (*Canthidermis maculata*) are common bycatch species across all oceans (Monin Justin Amandè *et al.*, 2011; Lawson, 1997; Rajruchithong *et al.*, 2005; Taquet *et al.*, 2008).

The species caught as bycatch have differing life histories and seasonal abundances. Certain species can be caught individually or within schools at different times of the year, causing the observer coverage needed to accurately estimate total bycatch to vary by species (Amande *et al.*, 2012). For species that are quite common in the bycatch, such as tunas and some bony fish, observer coverage rates do not need to be particularly high in order to accurately estimate total amounts, however for those species that occur very infrequently, observer coverage would need to be higher and such coverage is often not achieved with the available resources.

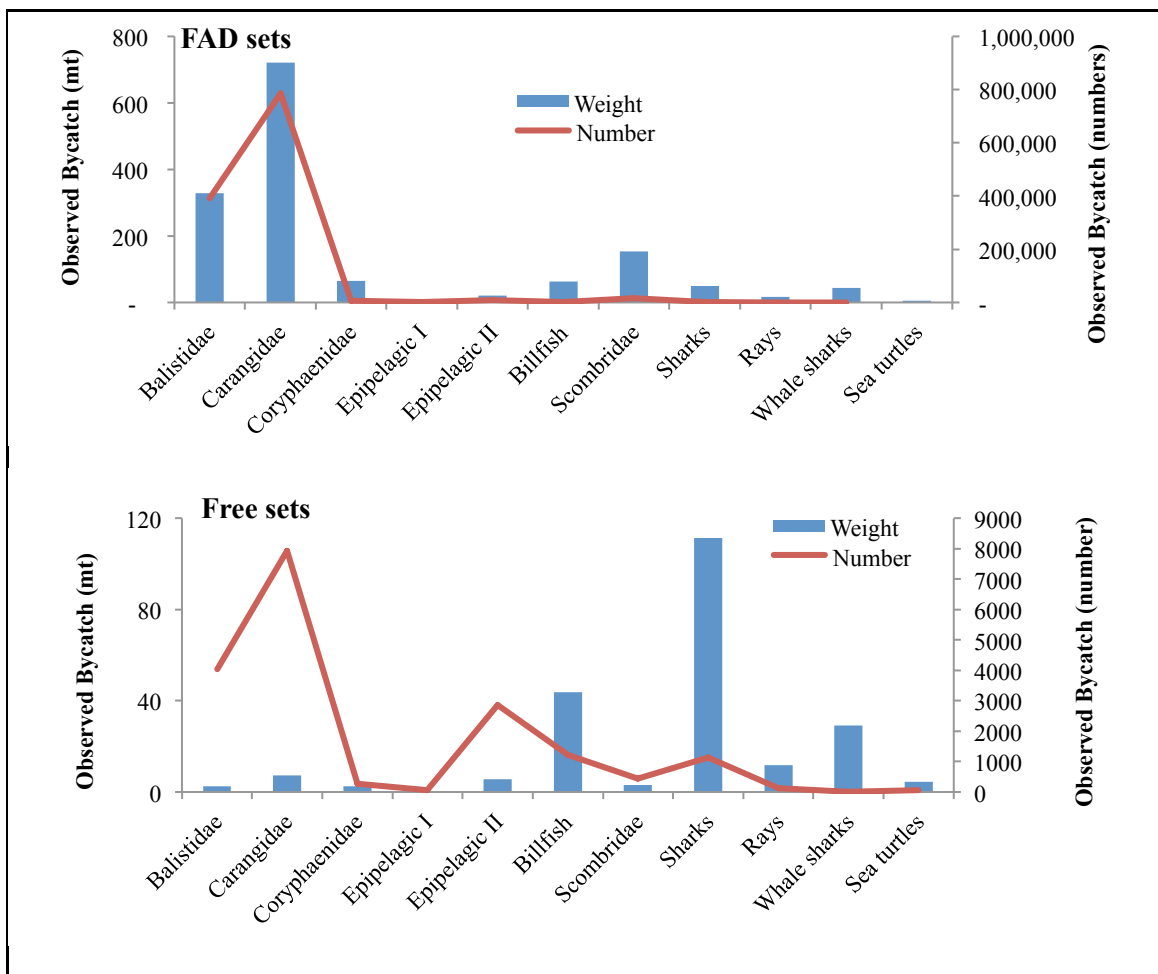

Figure 3. Total observed bycatch amounts for object associated sets (top panel) and free sets (bottom panel) from 2003-2013 from the EU tuna observer programs. Functional groups are defined in table 2.

Without 100% observer coverage onboard fishing fleets, statistical methods must be used to estimate the total amounts and composition of bycatch. There are several methods to estimate the total bycatch in a fishery, including models to estimate the total bycatch from observed data as well as ratio estimators which express the bycatch in ratio form (bycatch total/target catch total). Ratio estimators have been widely used to estimate total amounts of discards in fisheries, however this method is based on the assumption that discards proportionally increase relative to the catch (Amande *et al.*, 2012; Amandè *et al.*, 2010; Stratoudakis *et al.*, 1999). Using the bycatch and catch amounts recorded by onboard observers, a ratio estimator of bycatch to catch is obtained and this ratio can be applied to an auxiliary variable that is available to measure the entire fishery's activities. The auxiliary variable must be known at the fishery level, such as total landings, in order to be used as a proxy for total fishing activity (Borges *et al.*, 2005). However, the ratio estimate will be undefined for unsampled strata or for strata that have either no bycatch or no catches recorded. Methods to find missing ratios from unsampled strata include collapsing strata after sampling so that the ratio is based on several sampled trips or by using the average ratios of neighboring observed strata (Stratoudakis *et al.*, 1999).

This chapter estimates the total bycatch from the European Union tuna purse-seine fleet operating in the eastern tropical Atlantic Ocean using data provided by the Spanish and French observer program and the stratified ratio estimator method. The data was stratified by area, time period, year and fishing mode (free set or FAD set) and a Bayesian imputation model was applied to unobserved strata. These ratio estimates were then raised to the reported landings for the entire EU tuna purse seine fleet.

Methods

Data Preparation

The EU observer programs provided observer data; the collection and data management is split among three EU scientific institutions, IEO (Instituto Español de Oceanografía), AZTI Tecnalia and IRD (Institut de recherche pour le développement). The observer programs at IEO began in 2003, AZTI in 2004 and IRD in 2005. Data from the three scientific institutes reflects their respective start dates and continues until 2013. In total, there were 108 observed trips with 1,247 observed free sets and 1,244 observed FAD sets over this time period (Table 1). Observer coverage was obtained from published values and this information extends until 2009 (Figure 4) (Amandè *et al.*, 2010; Monin J Amandè *et al.*, 2011a).

Table 1. Overview of observer data for the three institutions.

	Time	Trips	FAD	Free
AZTI	2004-2010	13	74	14
IEO	2003-2013	43	594	479
IRD	2005-2013	52	556	754
Total	11yrs	108	1,224	1,247

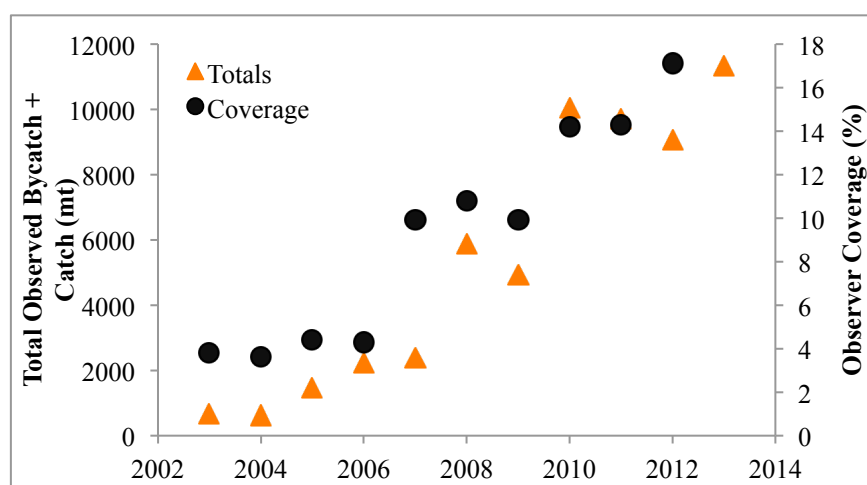

Figure 4. Observer coverage compared to total observed catches. Observer coverage calculated from observed sets to unobserved sets in European Observer program (Damiano *et al.*, 2014).

The onboard observers recorded the weight and number of the catch, discards and bycatch. Catches, including bycatch and discards, were identified at the species level and if this was not possible, they were classified at the family level. Catch amounts were estimated through both the known capacity of the brailer for each species of catch and the freezer well capacity onboard. For two of the institutions, fate of the discard and bycatch species were noted (e.g. discarded alive, retained). The location and type of set were also recorded (Figure 5).

The observed bycatch from the EU fleet for 2003-2013 was calculated as was the average bycatch and discards when they occurred in the sets. For the purposes of the remainder of the analyses in this paper, all three target species, skipjack, yellowfin tuna and bigeye tuna were grouped together and are termed catch hereafter. Small amounts of non-target scombrids were termed catch in the observer database and therefore were included in the catch amounts for this study. Discards of the target species were grouped into the tuna component of the bycatch. These discards occurred when the fishing process damaged target species and they were considered unfit for human consumption.

For the purposes of total bycatch estimations, the unit of measure was chosen at the set level rather than the trip level as trips contain both fishing modes: on free schools and on object associated sets. The data was stratified by year, area, season and fishing mode for each functional group. Seasons were determined using yearly quarters; quarter 1 corresponded to January-March, quarter 2 to April-June, quarter 3 to July-September and quarter 4 to October to December. Areas were defined as four quadrants: quadrant 1 was bounded by 0° N to 22° N and 0° E to 14° E, quadrant 2 by 0° N to 15° S and 0° E to 14° E, quadrant 3 by 0° N to 15° S and 0° W to 32° W and quadrant 4 by 0° N to 22° S

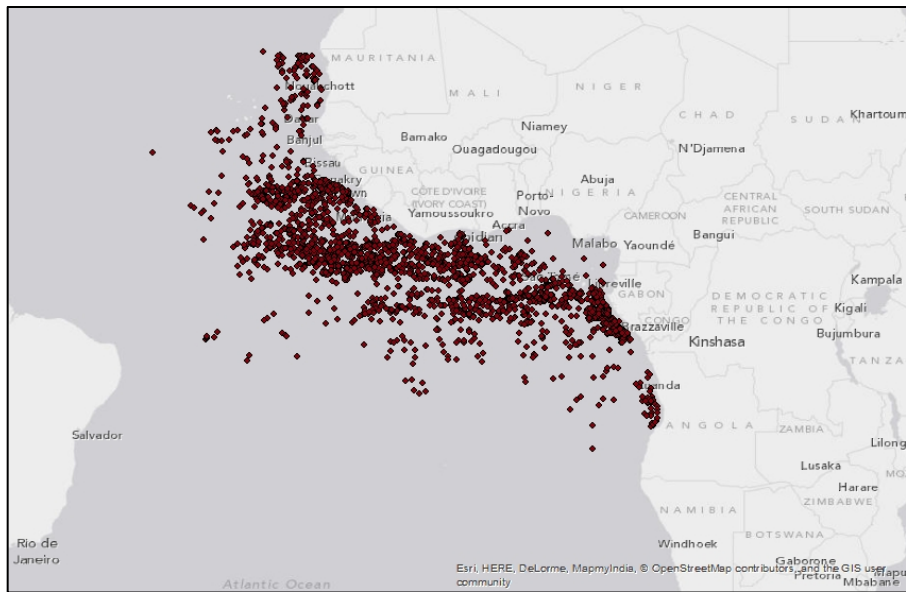

Figure 5. Location of both FAD and free observed sets from 2003-2013.

and 0° E to 32° W. The Task II catch/effort by fishing mode database supplied by the International Commission on the Conservation of Atlantic Tunas (ICCAT) was organized with the same stratification scheme of year, quarter, quadrant and fishing mode. Species comprising the bycatch were grouped either by family or similar ecological niche. These functional groups were further reduced into 5 groups composed of tunas, bony fish (all bony fish excluding tuna and billfish species), billfish, sharks (excluding whale sharks) and rays.

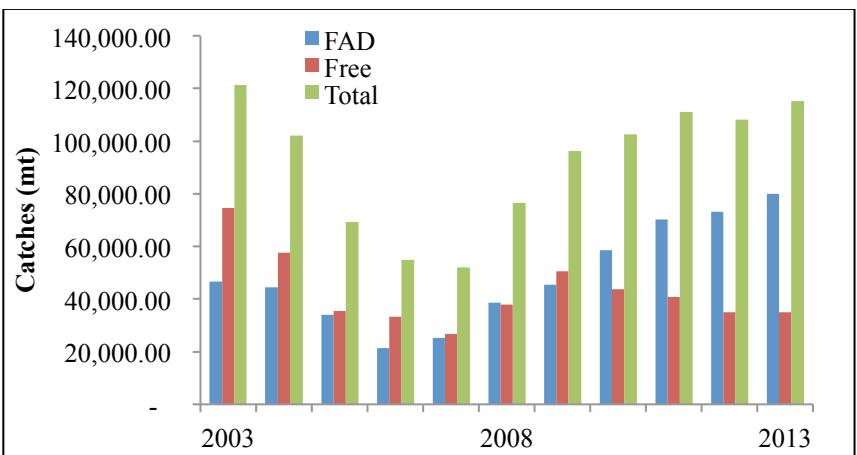

Figure 6. ICCAT Task II totals for all reported landings from EU purse seine fleet in the eastern tropical Atlantic.

Table 2. List of species included in each component of bycatch.

Tunas	Tuna discards	<i>Thunnus albacares</i> <i>Thunnus alalunga</i> <i>Thunnus obsesus</i> <i>Katsuwonus pelamis</i>	<i>Istiophorus albicans</i> <i>Makaira indica</i> <i>Makaira nigricans</i> <i>Tetrapturus albidus</i>
	Scombridae	<i>Acanthocybium solandri</i> <i>Auxis rochei</i> <i>A. thazard</i> <i>Euthynnus affinis</i> <i>E. alletteratus</i> <i>Sarda sarda</i> <i>Scomber spp.</i>	Billfish <i>T. angustirostris</i> <i>T. pfluegeri</i> <i>Xiphias gladius</i>
	Balistidae	<i>Balistes carolinensis</i> <i>Balistes punctatus</i>	Rays <i>Dasyatis violacea</i> <i>Manta birostris</i> <i>Mobula japanica</i> <i>M. mobular</i> <i>M. tarapacana</i> <i>M. thurstoni</i>
	Carangidae	<i>Canthidermis maculata</i> <i>Caranx crysos</i> <i>Elagatis bipinnulata</i> <i>Naucrates ductor</i> <i>Seriola rivoliana</i> <i>Uraspis helvola</i> <i>Uraspis secunda</i> <i>Uraspis sp.</i>	Sharks <i>Alopias spp.</i> <i>Carcharhinus falciformis</i> <i>C. longimanus</i> <i>Isurus oxyrinchus</i> <i>Prionace glauca</i> <i>Sphyrna lewini</i> <i>S. mokarran</i> <i>S. zygaena</i>
	Coryphaenidae	<i>Coryphaena equiselis</i> <i>Coryphaena hippurus</i> <i>Ablennes hians</i> <i>Lobotes surinamensis</i>	
	Epipelagic I	<i>Ruvettus pretiosus</i> <i>Sphyrna barracuda</i> <i>Tylosurus crocodilus</i> <i>Aluterus monoceros</i>	
	Epipelagic II	<i>A. scriptus</i> <i>Diodon eydouxii</i> <i>D. hystrix</i> <i>Echeneis naucrates</i> <i>Kyphosus sectatrix</i> <i>Lagocephalus lagocephalus</i> <i>Masturus lanceolatus</i> <i>Mola mola</i> <i>Psenes cyanophrys</i> <i>Ranzania laevis</i> <i>R. brachyptera</i> <i>R. osteochir</i> <i>R. remora</i> <i>Remorina albescens</i> <i>Tetraodontidae</i>	

Ratio Estimator

Total bycatch was estimated through the ratio estimator method, which assumes that bycatch is proportionally related to catch. To test this assumption, the stratified bycatch and catch totals were fitted with a linear regression model to examine correlation. The observer data was split by major bycatch group (tunas, bony fish, billfish, sharks and rays) and stratified by fishing mode, year, quarter, and quadrant. Using the stratified data, the relationship between each bycatch group's observed totals and the observed total catch was found using a linear regression. The relationship between all observed bycatch groups and the observed catch was also examined. This data was separated into fishing mode (free and FAD) and stratified by fishing mode, year, quarter, and quadrant.

For the remainder of the total bycatch estimation methods, predictor factors (year, fishing mode, quarter and quadrant) for bycatch ratios for each group were found using generalized linear models. The significant factors were selected using stepwise regression by AIC using the MASS package in R (Venables and Ripley, 2002). The set data was then stratified by the significant factors for each functional group and all total bycatch estimation methods were applied to the stratified data.

Bycatch ratios for each functional group (j) were calculated using the mean observed bycatch in each stratum divided by the mean observed catch for each stratum (Eq. 1) (Rao, 2000).

$$r_{jh} = \frac{\sum_{i=1}^n b_{ijh}}{\sum_{i=1}^n c_{ih}}$$

Equation 1

where r_{jh} is the rate of bycatch within stratum h of functional group j ; b_{ijh} is the bycatch in tonnes of functional group j of stratum h in set i and c_{ih} is the total observed catch (mt) in stratum h of set i . The ratio of bycatch to catch of functional group j in stratum h is then applied to the auxiliary variable of the total C from the Task II database from stratum h to yield the estimated total bycatch \hat{B} of each functional group:

$$\hat{B}_{1,j} = \sum_h^H C_h \cdot r_{jh}$$

Equation 2

The variance of the total estimated bycatch was found through equation 3 from the standardized bycatch reporting methodology (Wigley et al, 2007). This equation represents a first order Taylor expansion around the mean.

$$V(\hat{B}_{1,j}) = \sum_{h=1}^H C_h^2 \left(\frac{N_h - n_h}{n_h N_h} \right) \frac{1}{\left(\frac{\sum_{i=1}^n c_{ih}}{n_h} \right)^2} \left[\frac{\sum_{i=1}^n (c_{jih}^2 + (r_{s,jh})^2 c_{ih}^2 - 2r_{s,jh} b_{jih} c_{ih})}{n_h - 1} \right]$$

Equation 3

The total yearly estimate of bycatch by group was found through the summation of the total estimated bycatch \hat{B} and the total variance for each year was found through the same method.

Unobserved Strata

Ratios for unobserved strata are undefined and this paper uses three approaches for these undefined ratios to estimate the total bycatch: collapsed stratification, average ratio of neighboring observed strata and a Bayesian imputation model. Collapsed stratification used free and FAD ratios for each functional group and each year but does

not stratify by area or season, resulting in few or no unobserved strata in any years. The second method, using the average ratio of cells neighboring the missing strata, was termed the stratification method for simplicity. The average ratio of the quadrant was used for missing strata within quadrant, year and fishing mode. If no quadrant was observed, then the average ratio estimator of the year within the fishing mode was applied to unobserved strata and the total bycatch was found with equation 2.

Bayesian Model

Bayesian imputation models were used to find the missing ratios of the unobserved strata (Rubin and Little, 2002). The missing response data was missing in the form of the undefined, unobserved ratios. The year, mode, quarter and quad were known and fishing did occur in the missing strata as there was Task II reported landings from these unobserved strata. The BUGS software (Thomas, 1994) will automatically simulate the missing data according to the likelihood provided which was conditioned from the observed ratio estimates. The model ran on two different loops, the first using the real, observed data and the second loop predicted the unobserved ratio estimators using the same likelihood function. The log of the mean ratio for each stratum was found through a linear regression model using year, quadrant and mode as predictive factors.

$$\begin{aligned} \log(\text{Predicted Ratio}_{jh}) \\ = \alpha(\text{Year}_{jh}) + \beta(\text{Quadrant}_{jh}) + \gamma(\text{Mode}_{jh}) + \delta(\text{Quarter}_{jh}) \end{aligned}$$

Equation 4

The coefficients for each factor were given uninformative, normal prior distributions with a mean of zero and tau of 1.0 E-6. The likelihood function of the ratio (R) was based on a lognormal distribution,

$$\log(R) \sim (\log(\text{Predicted}R_{jh}), \tau_{jh})$$

Equation 5

Where τ is the inverse of variance for each stratum (h) and functional group (j):

$$\text{variance}(R_{jh}) = \left(1 - \frac{n}{N}\right) s_{jh}^2 / n \bar{b}_{jh}^2$$

Equation 6

$$s_{jh}^2 = \sum_1^n (c_{jh} - Rb_{jh})^2 / (n - 1)$$

Equation 7

The Bayesian model was run on R using the following packages: R2WinBUGS (Sturtz et al 2005), RJAGS (Plummer, 2015), R2JAGS (Su and Yajima, 2015) and RBUGS (Yan and Prates, 2013). The first 10,000 samples from the posterior distribution were treated as the burn-in period and every 100th samples were selected from the posterior distribution (n.thin=100). Convergence was determined with the Gelman-Rubin diagnostic with the coda package (Plummer et al, 2005). The total bycatch was found for each year by summing the mean estimates from the Bayesian results of each stratum within the year. For unobserved strata, the assumed variance of the mean estimates from

the Bayesian results was used to calculate the variance. The variance for the observed strata were found using equation 3. The variances for all the strata were added together to find the total variance for each year.

```

model {
  for (i in 1:N1) # Loop over observed strata{
    log.Ratio.pred[i]<a1[Year[i]]+b1[Quad[i]]+c1[Mode[i]]
    Ratio[i]~dlnorm(log.Ratio.pred[i],log.tau[i])
    RP[i]<-exp(log.Ratio.pred[i]-1.0E-7)
    TotBycatch[i]<-Ratio[i]*Totals[i]
    log.Ratio[i]<-log(Ratio[i]) }

  for(i in N2:N3) { #Loop over unobserved strata
    log.Ratio.pred[i]<a1[Year[i]]+b1[Quad[i]]+c1[Mode[i]]
    Ratio[i]~dlnorm(log.Ratio.pred[i],min.tau)
    RP[i]<-exp(log.Ratio.pred[i]-1.0E-7)
    TotBycatch[i]<-RP[i]*Totals[i]}

  for(j in 1:2){for(i in 1:11){
    SumTotBycatchYr[j,i]<sum(TotBycatch[][yr[,i]]*m[,i])}

  # Priors for factors
  for(i in 1:11)
  { a1[i]~dnorm(0,1.0E-6) }
  b1[1]<-0
  for(i in 2:4){b1[i]~dnorm(0,1.0E-6) }
  c1[1]<-0 #reference mode
  for(i in 2:2) { d1[i]~dnorm(0,1.0E-6) }

```

Figure 7. Code for Bayesian model.

Delta Model

A delta model was used to standardize and examine the overall trend in bycatch per unit effort (BPUE) for both FAD and free sets (Arrizabalaga *et al.*, 2003; Chyan-huei Lo *et al.*, 1992; Winter *et al.*, 2011). This model differs from the GLM conducted to determine significant factors for the stratification routine for the ratios to estimate total bycatch in that its purpose is to standardize the bycatch per unit effort (set) and determine if BPUE was increasing over the observed time series. Effort was calculated as the total number of observed sets. Data was stratified by fishing mode, year, quarter and quad. The lognormal transformed positive bycatch per set in each stratum were fitted using a

generalized linear model with a log link. Presence or absence of bycatch in each stratum was fitted using binomial model. Outputs aggregated by year from the best fitting GLM and binomial models were used to standardize BPUE from 2003-2013.

Results

The average annual total catch of the EU purse seine fleet between 2003-2013 was 76,978 mt for FAD sets and 65,011 mt for free sets (Table 3 and 4, Figure 6). According to the Bayesian method, average bycatch caught on all FAD sets in the same period was 6,498 mt, corresponding to 84.4 mt of bycatch for 1000 mt of catch. Annual average bycatch was 741 mt when fishing free schools of tuna, corresponding to 11.4 mt of bycatch for 1000 mt of catch.

Table 3. Totals of all bycatch for FAD sets for three estimation methods

	FAD Sets					
	Bayesian	SD	Stratified	SD	Collapsed	SD
2003	2,040	263	470	146	545	332
2004	16,071	10,159	16,398	9,171	16,365	7,492
2005	768	196	685	356	810	68
2006	212	26	221	45	286	38
2007	5,181	4,921	4,967	5,048	3,811	2,363
2008	4,120	1,229	4,102	2,056	4,587	802
2009	4,031	1,442	4,044	1,532	4,701	1,405
2010	8,498	2,595	8,688	4,363	7,584	1,831
2011	16,168	1,544	15,827	12,559	16,142	995
2012	7,392	2,186	7,386	2,471	9,019	1,595
2013	6,994	1,517	7,091	1,676	7,345	1,014
Avg. Bycatch	6,498		6,353		6,472	
Avg. Catch	76,978		76,978		76,978	
t/1000t catch	84.41		82.52		84.08	

Table 4. Totals of all bycatch for free sets for three estimation methods

Free Sets						
	Bayesian	SD	Stratified	SD	Collapsed	SD
2003	248	130	255	143	260	145
2004	569	303	245	52	218	190
2005	109	218	50	28	53	30
2006	36	9	56	33	68	38
2007	114	63	90	61	186	121
2008	68	25	70	38	72	31
2009	2,993	432	3,863	374	2,266	228
2010	1,363	742	1,362	760	1,211	742
2011	2,200	1,842	2,201	1,847	1,561	1,177
2012	137	62	134	68	113	53
2013	312	104	320	97	241	64
Avg. Bycatch	741		786		568	
Avg. Catch	65,011		65,011		65,011	
t/1000t catch	11.39		12.09		8.74	

The largest bycatch amounts seen in FAD sets belonged to Carangid species, followed by Balistidae species (Table 5). The most common discards for FAD sets were scombrid species and skipjack. FAD set catches were dominated by skipjack followed by almost equal amounts of yellowfin and bigeye tuna. The bycatch of free sets were composed mainly of billfish, followed by sharks while discards were mostly bigeye tuna. Free set catches were principally composed of yellowfin tuna, with much smaller amounts of the other target tunas caught.

Average discard fate (discarded dead, partially discarded, retained, used onboard, discarded alive, unknown and other) was also calculated where available in the database (Table 6). The discard rates for each functional group were calculated as a percentage of total individuals encountered by the observers. The largest bycatch group, Carangidae, was mostly used onboard (71%) or retained onboard (11%). Balistidae species were either discarded dead (44%) or alive (20%), while Scombridae were retained or used onboard (72%) as were Coryphaenidae (76%) and billfish (88%). Rays were usually

Table 5. Raw totals (mt) and averages (mt) of bycatch, discard and catch of each functional group across all observed sets from 2003-2013.

Bycatch Groups		FAD			Free		
		Totals	Average	SD	Totals	Average	SD
Bycatch	Balistidae	227.22	0.29	2.72	2.57	0.05	0.08
	Billfish	62.39	0.18	0.21	43.78	0.14	0.21
	Carangidae	231.24	0.25	0.61	7.35	0.14	0.19
	Coryphaenidae	63.29	0.09	0.14	2.54	0.05	0.09
	Epipelagic I	9.45	0.03	0.08	0.37	0.03	0.06
	Epipelagic II	19.41	0.07	0.5	4.95	0.03	0.05
	Rays	16.79	0.31	0.53	11.33	0.18	0.41
	Scombridae	151.2	0.21	1.89	2.94	0.06	0.11
	Sea turtles	5.14	0.07	0.09	4.6	0.07	0.1
	Sharks	36.72	0.13	0.21	34.08	0.41	0.74
	Small epipelagic	0.01	0.01	-	0	0	0
	Small mesopelagic				0.02	0.02	-
	Unknown	0.06	0.03	0.03	0.44	0.11	0.21
	Whale sharks	1.28	0.64	0.51	-	-	-
Discards	ALB	0.2	0.2	-	-	-	-
	BET	343.13	2.88	11.11	91.89	5.74	19.89
	Scombridae	709.24	3.35	6.49	19.74	0.94	1.71
	SKJ	673.91	3.72	8.06	24.28	1.21	2.73
	YFT	127.23	1.19	4.21	4.91	0.38	0.82
Catch	ALB	5.54	0.92	1.1	105.57	5.87	9.24
	BET	5,646.76	10.48	14.83	1,232.11	7.75	13.5
	Scombridae	498.97	3.28	5.04	29.85	2.49	3.76
	SKJ	15,277.26	18.59	25.59	2,985.64	17.26	20.11
	YFT	5,697.01	8.3	14.78	22,515.96	22.34	25.87

discarded dead (74%) with 20% discarded alive. Sharks had a similar alive discard rate of 17% and whale sharks were always a live discard as the net did not encircle the 2 individuals in the database. This was also the case with sea turtles with 96% of 109 individuals encountered discarded alive.

Ratio Estimators

Stratum bycatch for both FAD and free sets were linearly related to stratum catches, however, the linear relationship between observed FAD bycatch and catches was not significant (Figure 8). The results of the GLM to find significant factors for each

functional group's ratios are listed in Table 7. The only significant factors for tunas and billfish were year and mode. All the factors were significant for bony fish. For both rays and sharks, quarter was not significant for the ratio estimator and was not used. The stratification of year and fishing mode for tunas and billfish and sharks provided strata that were 76% observed with 24% unobserved. The stratification of year, quad and fishing mode for rays and sharks provided strata that were 64% observed and 36% unobserved while the stratification system for bony fish with resulted in only 42% observed strata and 58% unobserved. The collapsed ratio estimator method, which only split data by fishing mode and year, did result in some unobserved strata, as there were no rays recorded as caught for 2003-2005 by FAD sets and no recorded catches in 2004 for free sets.

Table 6. The fate of bycatch functional groups expressed as a percentage of the total number of individuals caught (Total) over the period 2003-2013.

FG	Dead Discard	Partial Discard	Retained	Used Onboard	Live Discard	Unknown	Other	Total
Carangidae	6.97	0.98	10.69	71.06	7.63	0.78	1.89	786,996
Balistidae	43.93	1.66	8.59	0.35	19.62	4.61	21.23	390,198
Scombridae	6.02	1.03	45.72	25.51	1.1	18.27	2.35	15,053
Epipelagic II	9.56	19.14	16.35	29.9	16.5	6.38	2.16	7,926
Coryphaenidae	9.23	2.51	55.72	20.12	0.86	10.08	1.48	6,768
Sharks	21.54	16.41	43.42	0.73	16.68	0	1.22	2,614
Epipelagic I	4.51	3.02	27.11	46.44	1.78	9.02	8.11	2,416
Billfish	7.15	0	82.67	4.61	0.32	3.97	1.27	629
Rays	73.85	2.31	3.08	0.77	19.23	0	0.77	130
Sea turtles	2.75	0	0.92	0	96.33	0	0	109
Small epipelagic	100	0	0	0	0	0	0	60
Unknown	47.83	52.17	0	0	0	0	0	23
Whale sharks	0	0	0	0	100	0	0	2

Table 7. Outputs of linear models used to identify significant predictor variables for ratio estimates.

TUNAS											
ALL	Df	SS	MS	F	P	Selected	Df	SS	MS	F	P
Year	10	226.07	22.61	4.69	< 0.01	Year	10	226.07	22.61	4.74	< 0.05
Quarter	3	21.21	7.07	1.47	0.23	Mode	1	546.86	546.86	114.75	< 0.01
Quad	3	6.41	2.14	0.44	0.72	Residuals	169	805.42	4.77		
Mode	1	539.10	539.10	111.86	< 0.01						
Residuals	163	785.55	4.82								
BONY FISH											
ALL/Selected	Df	SS	MS	F	P						
Year	10	99.65	9.97	3.75	< 0.01						
Quarter	3	30.20	10.07	3.79	0.01						
Quad	3	23.73	7.91	2.97	0.03						
Mode	1	454.11	454.11	170.78	< 0.01						
Residuals	163	433.42	2.66								
BILLFISH											
ALL	Df	SS	MS	F	P	Selected	Df	SS	MS	F	P
Year	10	48.75	4.88	1.98	0.04	Year	1	7.80	7.80	3.10	0.08
Quarter	3	2.21	0.74	0.30	0.83	Mode	1	25.02	25.02	9.93	< 0.01
Quad	3	3.50	1.17	0.47	0.70	Residuals	178	448.46	2.52		
Mode	1	24.58	24.58	9.96	< 0.01						
Residuals	163	402.23	2.47								
SHARKS											
ALL	Df	SS	MS	F	P	Selected	Df	SS	MS	F	P
Year	10	73.99	7.40	3.16	< 0.01	Year	10	73.99	7.40	3.13	< 0.01
Quarter	3	17.11	5.70	2.44	0.07	Quad	3	33.76	11.25	4.76	< 0.01
Quad	3	28.06	9.35	4.00	0.01	Mode	1	29.19	29.19	12.35	< 0.01
Mode	1	28.75	28.75	12.29	< 0.01	Residuals	166	392.41	2.36		
Residuals	163	381.43	2.34								
RAYS											
ALL	Df	SS	MS	F	P	Selected	Df	SS	MS	F	P
Year	10	16.63	1.66	2.08	0.03	Year	10	16.63	1.66	2.07	0.03
Quarter	3	6.56	2.18	2.74	0.05	Quarter	3	6.56	2.18	2.71	0.05
Quad	3	7.57	2.52	3.16	0.03	Quad	3	7.57	2.52	3.13	0.03
Mode	1	1.87	1.87	2.34	0.13	Residuals	164	132.04	0.81		
Residuals	163	130.17	0.80								

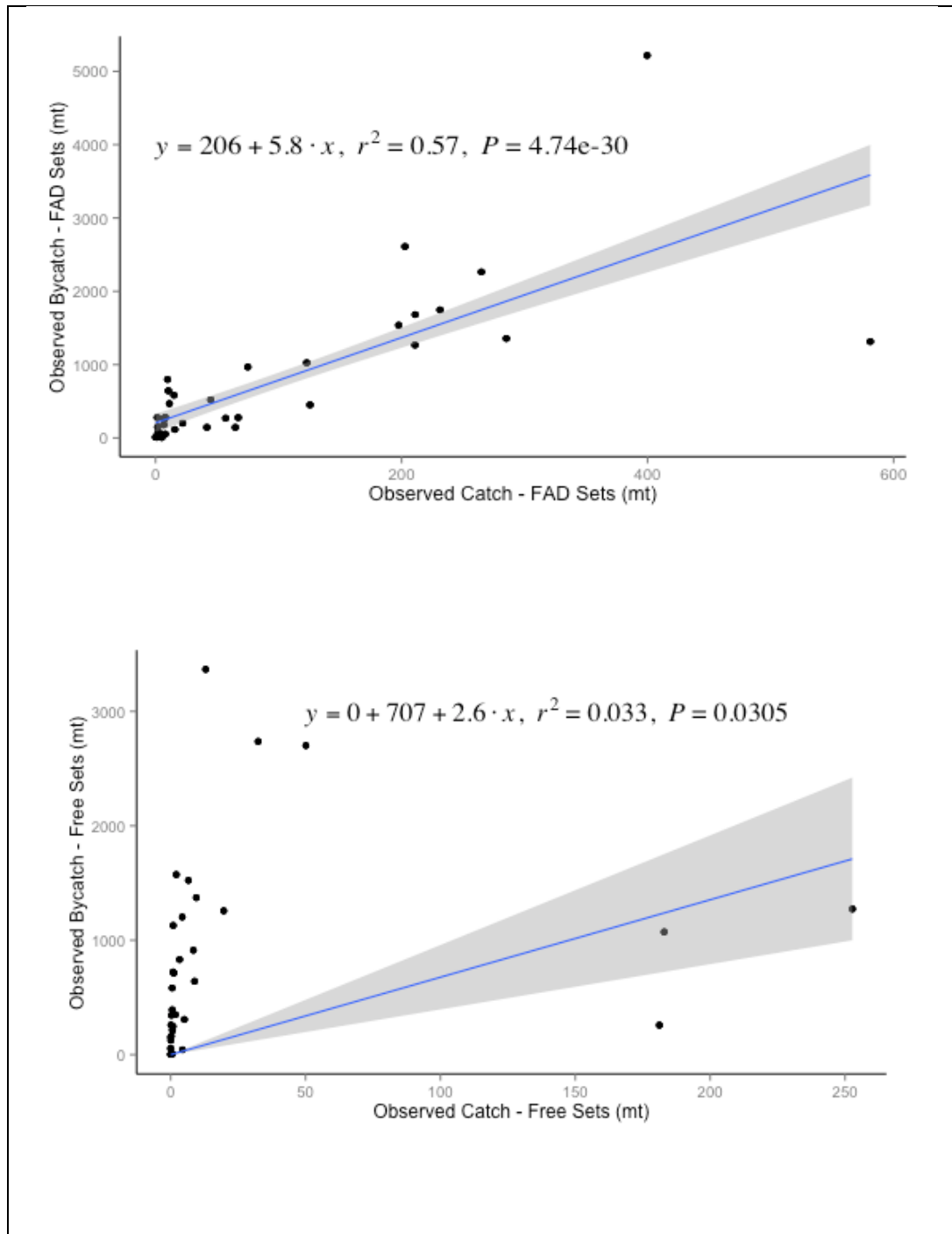

Figure 8. Linear regression model on stratified observed totals for FAD sets (top panel) and free sets (bottom panel) with 95% confidence interval in grey shading.

The differences between the three estimation methods showed no clear pattern in the amounts of total bycatch, but in general the Bayesian model and the stratified model with the average ratio for the missing stratum were similar (Figure 8). Tuna bycatch in FAD sets in 2004 was significantly larger than in subsequent years, however the variance of this year's estimate for all three estimation methods was very large, casting doubt on the high levels of bycatch estimated. A similar situation occurs with the estimates of bycatch of tuna in free sets for 2011. Bony fish bycatch estimates for FAD sets in 2011 are highly uncertain while the higher estimates for the free sets in 2010 have a higher confidence level. The remainder of the groups; billfish, sharks, and rays, have less variable bycatch estimates throughout the years. The exception to this is the 2009 free set bycatch estimates for sharks. The variability of the shark collapsed ratio estimator is extremely high, however this high variance is not seen in the other two estimation methods.

The significant factors for the ratios in both tuna and billfish bycatch were just fishing mode and year, resulting in no unobserved strata. This precluded the necessity of applying the stratified method and the Bayesian method to estimate missing ratio estimators. However, for sake of comparisons, both estimation methods were applied to the stratified data that did result in missing strata (year, mode and quadrant). The collapsed ratio estimator was extremely similar to results obtained through further stratification for FAD sets, although the collapsed ratio estimator gave smaller total

estimates of tuna bycatch caught in free sets than the other two estimation methods.

Billfish had consistent levels of total estimated bycatch across the three methods with the exception of 2008 FAD sets and 2007 free sets.

The Bayesian model appeared to be well converged, both the Gelman-Rubin diagnostic and the Rhat values were 1 or close to 1 (1.0001). The posterior distributions for the majority of the estimates had a reasonable distribution (Figure 11).

Delta Model

The binomial model that best fit the FAD set BPUE data had year, quad and catch as explanatory variables while the best fitting lognormal GLM model used year, quarter, quad and catch. The binomial model that best fit the free set BPUE data had year, quad and catch as explanatory variables while the best fitting GLM model used year, quarter, quad and catch (Figure 12). The standardized BPUE amounts showed that the BPUE did not increase over the ten year period for either free or FAD sets. The largest levels of uncertainty were in 2005 and 2009 for FAD sets and 2004, 2007 and 2012 for free sets (Figure 13). This matches with the large levels of uncertainty seen in the total bycatch estimates.

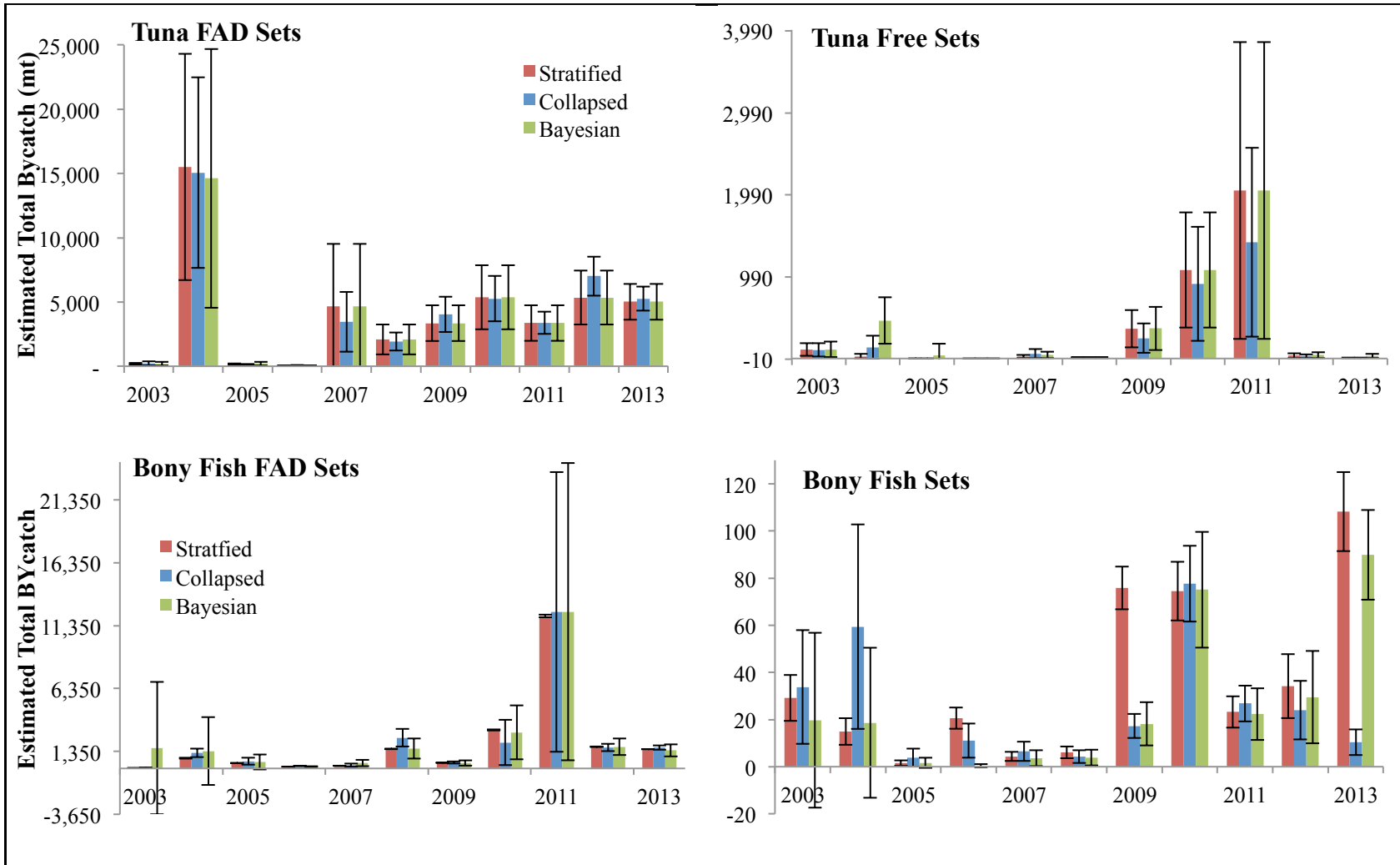

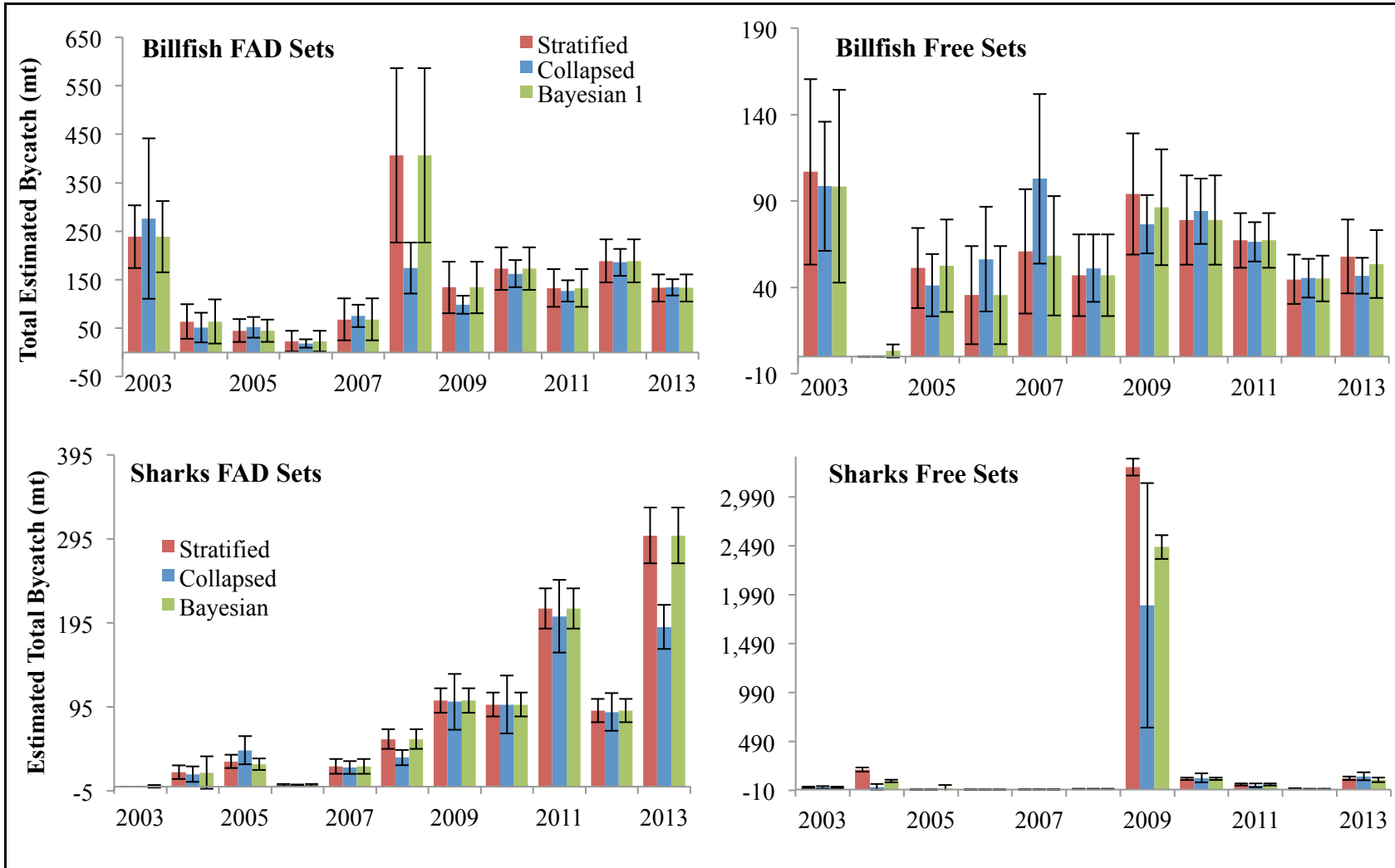

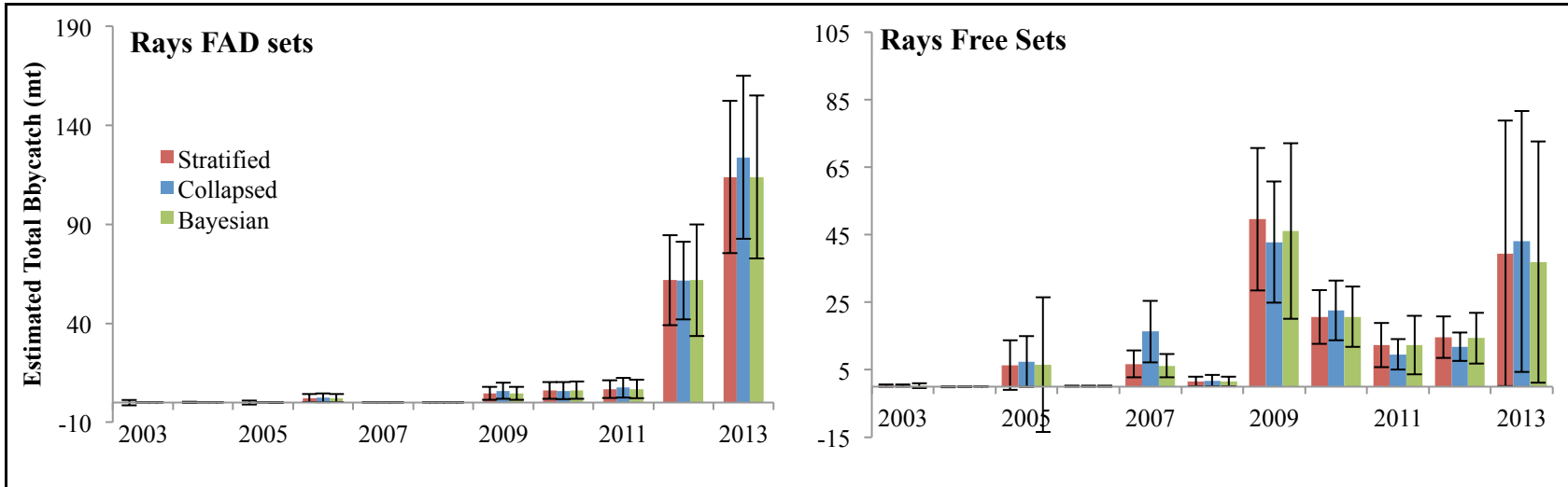

Figure 9. Bycatch estimates for each functional group using the three estimation methods, stratified using ratios for neighboring strata, collapsed and Bayesian.. Error bars represent one standard deviation of the estimated total bycatch.

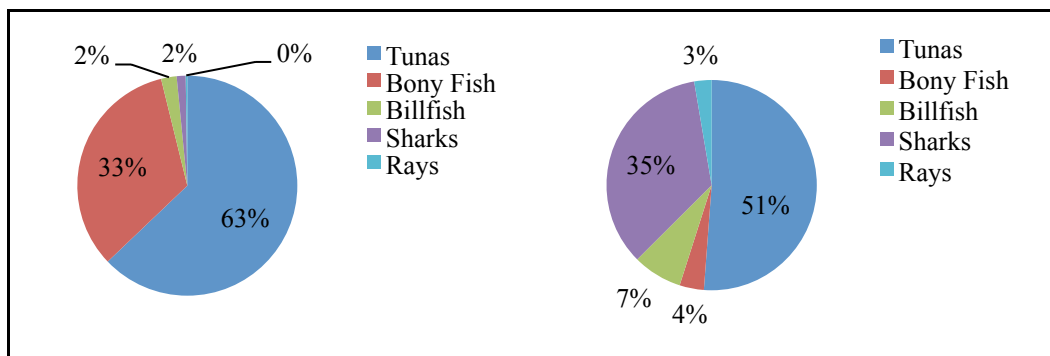

Figure 10. Composition of bycatch for FAD sets (left panel) and free sets (right panel).

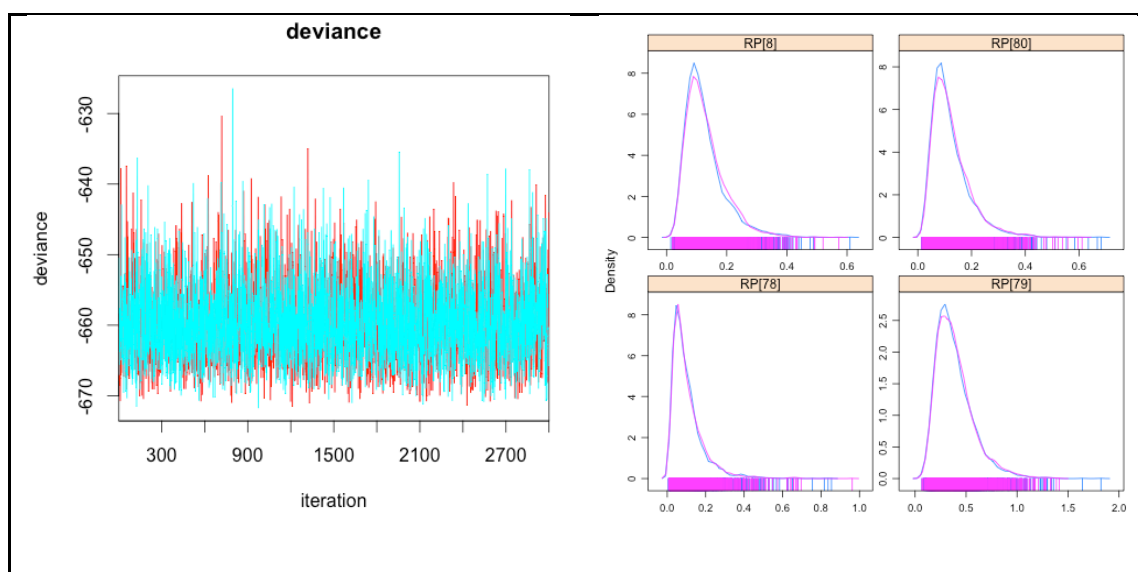

Figure 11. Deviance of Bayesian model 1 and sample of predicted ratio estimator posterior distributions.

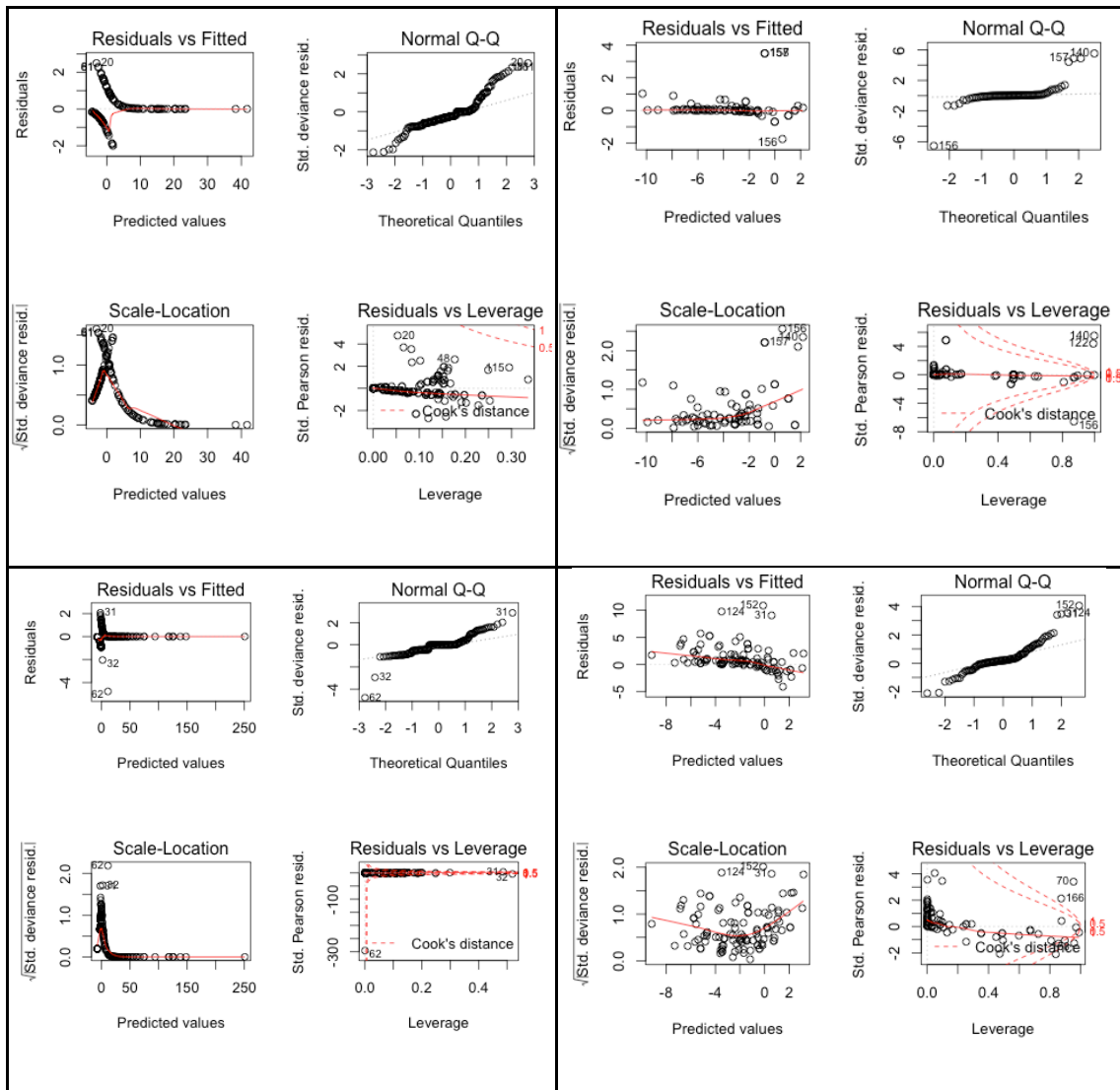

Figure 12. Diagnostic plots for FAD BPUE binomial and GLM models (top panel, left and right) and free BPUE binomial and GLM models (bottom panel, left and right).

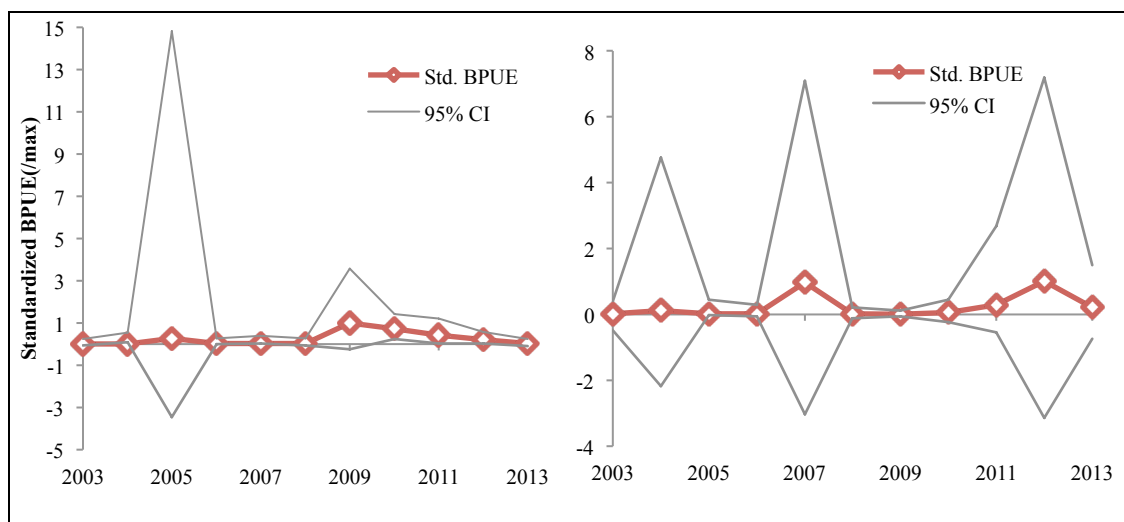

Figure 13. Standardized BPUE with nominal BPUE and 95% confidence intervals for FAD sets (left panel) and free sets (right panel).

Discussion

Estimation Methods

With the exception of billfish, the bycatch total estimates showed a general increasing trend across the years for both FAD and free sets. This is most likely the result of an increase in catches observed in the last 5 years of the time series and not any increase in bycatch rates as the BPUE index remained relatively stable in the last decade for both free and FAD sets (Figure 6). The observer coverage in the EU tuna purse seine fleets has been approaching 10% and this is most likely insufficient to understand the finer scale processes that can affect the amounts and composition of the bycatch. Logbook data recorded by the ship's captain can also provide important information on catch

composition and extrapolation of bycatch amounts, the number of sets made within a trip can be underreported as fishing masters do not always enter in sets that did not result in catch, causing an underrepresentation of total sets actually made (Amande *et al.*, 2010).

While the total estimates using the nearby averages in missing strata and the Bayesian model were similar across bycatch groups and years, the Bayesian methodology allows for a more statistically accurate estimate of the missing data. This is also the case with how the Bayesian modeling approach handles uncertainty within the model. The Bayesian modeling approach used in this paper assumed the reason for the unobserved strata was ignorable, meaning the unobserved strata have the same characteristics as the observed strata and there is nothing would cause differences between the observed and unobserved ratio estimators. As there is not enough data to fully explore the other options, that the mechanism behind the missing data is not ignorable and the unobserved strata have differences affecting bycatch amounts, this assumption is necessary (Little and Rubin, 2014). The potential for bias within the observer database exists as there may be a non-representative deployment of observers onboard vessels and/or a change in the normal fishing behavior of the vessel with the presence of an observer (Hall and Roman, 2013).

Totals of the tuna bycatch in free sets are much greater than the totals obtained through the other estimation methods, however, the tuna bycatch caught by free sets in this paper is significantly smaller than other reported bycatch amounts using the same EU observer database. This most likely the result of the data provided for this work as the area of reported bycatch is site of the heaviest FAD fishing, while free sets are further dispersed than the area of interest for this research.

The variance obtained through the Bayesian model, collapsed stratification and the average ratio methods were within similar ranges. The disadvantage of the collapsed stratification method is that fine detail is lost about the area and season, however each ratio is based on several strata, potentially minimizing the variance of the estimates as was observed in certain years (Stratoudakis *et al.*, 1999).

Stratification allows for the further analysis into the effects of moratoriums in place throughout certain areas of the Gulf of Guinea. Two moratoriums were in place during the collection of the data used in this study, a FAD seasonal moratorium from 1997-2005 and a seasonal no-take area for surface fleets from 2005-2010 (Torres-Irineo *et al.*, 2011). The FAD moratorium caused the fleet to spread outward from a concentrated area in the South Sherbro Area and increased the numbers of free sets during the months the moratoriums were in place. These shifts in effort and area will effect how the stratification regime estimates total bycatch. On the other hand FAD moratoria often have resulted in mandatory 100% observer coverage during a FAD closure to be imposed for purse seine fleets in the area of the closure (Anonymous 2014), or in the whole fishery (Anonymous 2015). In both cases such increase in observer coverage would presumably generate better data on bycatch for that period.

The use of sets as the measuring unit instead of trips was necessitated by trips containing both types of sets, free and object associated, however the use of trips as the measuring level has been shown to decrease variability in discard estimates (Borges *et al.*, 2005). The previous estimation studies utilized set as the unit rather than trip for same reasons as this paper (Amandè *et al.*, 2010). Factors that affect sets, such as time of day and sea conditions, leads to a higher variability between sets as compared to trips. Studies

estimating the discards in the North Sea haddock and cod fishery found that the haul level of the trawl fishery was an inappropriate unit if the aim was to minimize variance (Borges *et al.*, 2005; Tamsett and Janacek, 1999). Additionally, observer data has a hierarchical structure, as sets are nested within trips and trips within fleets. This would seem to necessitate multilevel models to estimate bycatch, however this would require a detailed knowledge of fleet and trip dynamics which is missing in this fishery (Borges *et al.*, 2005). Previous studies concluded that vessel size effect did not need to be included in the analysis as it was not a factor in the species composition of the sets (Pallares and Hallier, 1997)

The use of ratio estimators is founded on the assumption of the linear relationship between bycatch and fish production, however this is an approximation as bycatch is not always zero when there are zero catches as null sets can be made on incorrectly interpreted acoustic data (Moreno *et al.*, 2007b). There is some evidence with tuna purse seines that smaller catch sizes in individual sets can result in larger amounts of bycatch (Dagorn *et al.*, 2012). Sets under 10 mt in the Atlantic Ocean account for 41% of all sets made and the bycatch to catch ratio for these small sets was 121 mt per 1000 mt of catch. The data used in that study was not separated by fishing mode, however the ratio observed was far greater than the average bycatch ratio in this study (31mt/1000mt for FAD sets and 12mt/1000mt free sets). Additionally, the chosen auxiliary variable may not always respond linearly with discards (Tamsett and Janacek 1999; Rochet and Trenkel 2005). The ratio estimator is widely used in fisheries science; however, it can introduce biases and uncertainties due to stochastic processes that influence the fishery as

a whole (Stratoudakis *et al.*, 1999). An issue can also occur with small sizes of the observed auxiliary variable which is the denominator in the bycatch ratio, as the ratio estimator can give unrealistically high estimates for total discards.

Landing data was used as the auxiliary variable, however landing data may not be accurately reported. Purse-seine vessels target schools of tuna and these schools are either mono-specific or a mixed school of tuna, in either case the schools are made up of similar size classes within species or across species. The landings data used was solely for the EU tropical tuna purse seine fleet, however fishing methods between the French and Spanish purse seines do differ. On vessels without observers, the total catches can be different than the reported landings as fish can be consumed onboard by the crew, transshipped at sea to another vessel or discarded later on in the trip to make room for higher value species or individual fish (Cotter and Pilling, 2007). If this occurs, so called “high-graded”, can increase the bycatch to catch ratio. Catches that would have been retained for landing are instead discarded at sea, adding to the total negative impacts on the fishery (Davis, 2002).

Patterns in Bycatch Amounts and Composition

Tunas make up the majority of the bycatch in the purse seine fishery. Previous estimates of purse-seine bycatch were comprised of 83% of tuna species (Amandè *et al.*, 2010). Like this paper’s results, the 2010 EU bycatch estimates had bony fish as the second major component of the bycatch with billfish as the third largest component. This is in contrast to previous estimates from the 1990s that placed sharks as the third major component. It has been proposed that this reflects a shift in the abundance between sharks

and billfish, occurring around 1999 (Gaertner *et al.*, 2002; Torres-Irineo *et al.*, 2014). The bycatch and discards of the EU purse seine fleet in the Atlantic for 2008-2009 were estimated to be about 11,100 t while the EU landed tuna catch was 91,330 for the same period, or 120t of bycatch/1000t of tuna (Amandè *et al.*, 2011). Of this bycatch, the majority (80%) was tuna not considered marketable or fit for human consumption and the rest was comprised of small teleosts (14%), billfish (3%) and elasmobranchs (3.3%) (Amandè *et al.*, 2011). The annual amount of bycatch was higher in 2008-2009 than in 2003-2007, perhaps the result of increased fishing pressure from vessels displaced by piracy from the Indian Ocean. This study also estimates increase in bycatch in 2009, however the amounts did remain relatively stable after 2009, with the exception of FAD caught sharks in 2011. As previously noted, this paper's estimates of tuna caught in free schools are significantly lower than the reported in the Amandè et al paper. However, any discrepancies in results are most likely the result of differences in data used as well as stratification regimes (Table 8).

A study examining the same fishery for an earlier time period, 1997-1999, showed lower bycatch estimates than were obtained from the estimates obtained here and the previous studies from the 2000's. However, that is the likely result of the design of the research as the cruises were specifically organized to observe bigeye in the fishery and not directly related to other bycatch species (Fonteneau *et al.*, 2000a; Torres-Irineo *et al.*, 2014). The bycatch rate from the EU estimates from 2008-2009 are higher than those observed in the Indian Ocean, 67.2 t/1000 t of tuna in FAD sets and 19.2 t/1000 t of tuna in free sets (Amandè *et al.*, 2012; Rajruchithong *et al.*, 2005). The higher bycatch amounts in the Indian Ocean is in contrast to the lower rate in the Atlantic, however there

exists no market for small tunas in the IO as it does in west African “*faux poisson*” markets. The difference in bycatch rates may be the result of different market pressures or oceanographic differences causing differences in abundance, productivity and catchability of smaller tuna in the Indian Ocean (Amandè *et al.*, 2010).

Table 8 Comparisons between Bayesian model 1 and previously published total bycatch estimates.

2003-2007 avg.	Free		FAD		Totals	
	Bayes1	Amandè	Bayes1	Amandè	Bayes1	Amandè
Production	45,538	45,222	34,343	34,076	79,880	79,298
Bycatch	208	1,284	4,694	5,121	4,902	6,405
Tunas	130	941	3,943	4,384	4,073	5,325
Bony Fish	14	35	639	580	653	615
Billfish	50	233	88	88	138	321
Sharks	14	13	24	61	38	74
Rays		62		8	4	70
2008	Free		FAD		Totals	
	Bayes1	Amandè	Bayes1	Amandè	Bayes1	Amandè
Production	37,881	39,503	38,638	41,016	76,519	80,519
Bycatch	66	1,529	4,150	9,905	4,216	11,434
Tunas	10	1,296	2,079	7,544	2,090	8,840
Bony Fish	4	115	1,608	1,834	1,612	1,949
Billfish	47	101	406	460	454	561
Sharks	5	12	56	51	61	63
Rays		5		16	3	21
2009	Free		FAD		Totals	
	Bayes1	Amandè	Bayes1	Amandè	Bayes1	Amandè
Production	45,510	48,754	50,652	44,290	96,162	93,044
Bycatch	2,949	4,253	4,023	6,862	6,972	11,115
Tunas	366	3,719	3,353	5,138	3,719	8,857
Bony Fish	21	188	434	1,418	454	1,606
Billfish	86	99	134	165	221	264
Sharks	2,476	221	102	129	2,579	350
Rays		26		12	48.3	38

Species composition across the time periods using the data collected from the BET observer program found that the species composition does not appear to be different between sets or the 2 time periods for which data is available. The highest probability of occurrence in a set is bony fish (0.9) and the lowest probability of occurrence is for sea

turtles (<0.2). Estimates of total species richness in FAD sets had a maximum of 87 species while for free sets species richness was a 61 maximum species (Torres-Irineo *et al.*, 2014).

This paper did not estimate the total bycatch of sea turtles as they are rarely caught during purse seine fishing operations. When they did occur in the observer database, they were either sighted within the net or near the FAD. If brought onboard, they are discarded alive. However, the observer data cannot take into account juvenile turtles that may become entangled in FADs. Ghost fishing, or fishing by abandoned fishing gear, can cause significant and unobserved mortality in both sea turtles and sharks. Silky shark mortality was estimated at 5-10 times higher than observed mortality onboard fishing boats in the Indian Ocean (Filmalter *et al.*, 2013). Other species have the potential to become entangled in abandoned FADs and so the impact of the fishery can be greater than estimated from observer programs, however the new recommendation by ICCAT will require all FADs to be non-entangling by 2016 (ICCAT 2014).

In certain fisheries, it is possible to validate total estimates obtained from observer programs or other means through landings or export data (Clarke *et al.*, 2006, 2005), however validating bycatch amounts is problematic as no market exists for the vast majority of species caught as bycatch. The “*faux poisson*” market in Abidjan, Côte d’Ivoire presents a unique opportunity to compare some bycatch species estimates to the landings reported. Landings of bycatch destined to the local “*faux poisson*” estimated for the EU purse seine fleets have been estimated to have varied between 5,000 and 10,000 mt a year since 2000 (ICCAT 2015) and are mostly comprised of skipjack and small scombrid species (Chavance *et al.* 2011, Chavance *et al.*; 2015). The yearly average

estimated bycatch of tunas within this study is 4,439 mt and considering 45% of scombrids are retained onboard (Table 6), total landings of scombrids to the “*faux poisson*” market could reach close to 2,000 mt a year. However, the total estimates of tuna bycatch in this study are lower than reported previously (Amandè *et al.*, 2010; Monin *et al.*, 2008), so total scombrid landings are most likely larger and in line with what has been reported (Chavance *et al.*, 2015, 2011).

Conclusion

The ratio estimator method to find total bycatch amounts is one of the most widely used estimation methods and presents the best option to evaluating total bycatch taken by fisheries in the absence of 100% observer coverage. The Bayesian model to estimate total bycatch provides a more statistically valid method to treat uncertainty and missing data. However, the major assumption the ratio estimator methods is based on, that bycatch is linearly and positively related to catches may not always be valid in certain fisheries. There is some evidence in the tuna purse seine fishery that smaller sets in terms of catch tonnage have higher ratios of bycatch to catch and smaller ratio as catches increase (Dagorn *et al.*, 2012). This implies the bycatch amounts per set are not linearly related to the set’s catch. If that were true, decreasing the total number of sets overall to fewer sets with large catches could potentially reduce the impact on bycatch species from purse seining.

Total bycatch amounts need to be estimated separately for the different fishing modes of purse seine vessels as FAD sets result in higher bycatch. An increase in the proportion of FAD sets to free sets will lead to both a larger total bycatch and a larger

number of species contributing to the bycatch as more species aggregate around FADs. The estimates of tuna bycatch in this paper, while lower than previous estimates, are consistent with reported landings of scombrids in the “*faux poisson*” markets. In addition to the bycatch biomass sold in local markets, a large portion of the biomass caught as biomass is either consumed onboard (Carangidae) or discarded dead (Balistidae). While some bycatch is discarded alive, the long-term survival of the discards is unknown. Methods to quantify post-release survival are presented in Chapter 3 and 4. In summary, the total biomass removed by the tuna purse-seines from the ecosystem is larger than the total reported landings. The consequences of this biomass removal will be further examined in Chapters 5 and 6.

Chapter 3: Reflex impairment as a measure of delayed mortality in a tuna purse-seine bycatch species, grey triggerfish (*Balistes capriscus*)

Overview

The Atlantic tropical tuna purse-seine fleet targets skipjack (*Katsuwonus pelamis*), yellowfin (*Thunnus albacares*) and bigeye tunas (*Thunnus obesus*). These species can form large schools under floating objects, allowing for easier location by fishermen. The increased use of man-made fish aggregation devices (FADs) has raised concerns due to the wide variety of marine life that are associated with them and can be incidentally caught by purse-seine vessels, particularly shark and turtle species. With the exception of tunas, however, the most commonly discarded bony fish, in the purse seine fishery by both weight and number are species of the family Balistidae (Amandè *et al.*, 2010; Monin J Amandè *et al.*, 2011a). The Balistidae family is comprised of 42 species that are found in the three major ocean basins, three species of which are commonly found in tuna bycatch: *Balistes capriscus*, *Balistes punctatus* and *Canthidermis maculata* (Freon and Dagorn, 2000; Moreno *et al.*, 2007a). Balistidae seen around FADs have been observed with significant scarring from fishing gear, suggesting that they were either able to escape the gear and survive, or survived after being released from the vessel (Ménard *et al.*, 2007).

At-sea discards can cause uncertainty in determining the total impact the fishery has on the surrounding ecosystem as it is difficult to estimate the survival of the discarded species (Gilman, 2011; Crowder and Murawski, 1998; Lawson, 1997). Post-release survival studies have been conducted using mark and recapture methods, however these are expensive and are not feasible for all bycatch species (Pollock and Pine, 2007)

Traditionally, studies on post-release survival have examined physiological measures of stress including the blood plasma variables lactate, glucose, potassium, and sodium. The usefulness of these measures to predict mortality depends on how closely tied they are to behaviors necessary for survival, such as feeding and predator evasion (Davis, 2001). However, the linkage between concentrations of these variables and delayed mortality is not always clear, in part because of the high degree of individual variability of blood plasma measurements. Previous studies have found a lack of correlation between measured concentration levels of plasma variables and mortality; Davis (2001) measured the stress response of sablefish using cortisol and lactate and found no correlation between elevated levels of these stress parameters and mortality (Davis, 2001). Measuring discrete components of the stress response does not offer information on the chances of survival, however, using a direct measurement of the whole animal's reaction to stress can provide a straightforward method to estimate mortality outcomes of discard species in fisheries (Davis, 2010, 2007).

Reflex impairment, as a whole animal indication of stress, can be correlated with the classic stress responses of impaired growth, complications with predator evasion and delayed mortality (Davis, 2007; Raby *et al.*, 2012). The reflex responses consist of involuntary actions that constitute complex behaviors that are central for the fitness of both the individual and the health of the population (Davis, 2007). Reflexes can be observed in free-swimming and restrained fish and are easily scored as present or absent; restrained fish responses include body flexion, dorsal fin erection, and operculum reflexes. Measuring a suite of reflexes in unstressed and stressed fish and assessing their

reflex impairment against delayed mortality allows for a reflex action mortality predictor (RAMP) curve to be estimated. The RAMP curve can be used in fishing operations to provide an expeditious and inexpensive method to estimate discard mortality, once it has been validated for the species of concern.

This study identified reflex responses that are consistently present in unstressed grey triggerfish (*Balistes capriscus*). Grey triggerfish were chosen as the study species as they are common to the tropical eastern Atlantic, where the tuna purse-seine fleet operates, and to southern Florida, where the laboratory study was conducted. Additionally, the grey triggerfish morphology is similar to that of other Balistidae species present in the bycatch. Among the many stresses that fish sustain during capture by a purse-seine vessel, crowding inside the net while in the water, and air exposure once taken out of the water are the most common damaging stressors leading to mortality (Marcalo *et al.*, 2010; Marçalo *et al.*, 2006). In this study, air exposure was used as the main stressor to simulate stress from purse seining, although fish were also exposed to some crowding prior to air exposures. Reflex impairment was measured after different air exposure times and delayed mortality was recorded when it occurred following air exposure. From this, a reflex action mortality predictor curve was developed. Future studies will assess the identified reflexes from this study in triggerfish caught by purse-seine vessels prior to discard; the delayed mortality curve developed here will be validated onboard a purse-seine vessel under normal fishing operations.

Methods

Grey triggerfish (*Balistes caprisкус*) (31.98 cm \pm 3.95 fork length FL) were collected from near-shore waters in Miami, Florida (Figure 14). This species was selected as it is common to both the Florida patch reef environment, where the study was conducted, and the Gulf of Guinea (Aggrey-Fynn, 2009), where an extensive tuna purse-seine fishery operates. Four separate groups of fish were collected from the same location (Groups I-IV). Group I was collected in July 2013, group II was collected in August 2013, group III was collected in October 2013 and group IV in February 2014. The fish were transported to the University of Miami's Experimental Hatchery located on Virginia Key, Florida and held according to the University of Miami's guidelines for experimental animals (IACUC protocol 13-025). Fish were immediately treated with a freshwater bath to remove any parasites and placed in 3,700 liter holding tanks. The fish were treated with formalin at 100 ppm for 1 hour to remove any remaining parasites the day following collection. The holding and stocking tanks were supplied with a flow-through seawater system filtered with a 10- μ m mesh sock. Temperature ranged from 26-30° C with oxygen saturation > 95% throughout all acclimation periods and experiments. For the duration of the experimental and holding periods, fish were fed to satiation on diet of bait shrimp and squid six days a week (Vose and Nelson, 1994). After an acclimation period of 3 days, the fish were injected with Biomark HPT12 PIT (Passive Integrated Transponder) tags. Injection sites were treated with Betadine and fish had a further 7-day acclimatization period before stress testing began.

The reflex testing followed the methods outlined in Davis (2010), beginning with determining the stimuli that will result in consistent, involuntary movements in unstressed control fish. Fish are then exposed to relevant stressors that exist in either the fishery or aquaculture operation, such as tow duration or air exposure. Any direct mortality from the stressor is identified and the reflexes are not measured. Immediately after the stressor, the reflexes identified in the unstressed fish are again measured. The total impairment, RAMP score, for each fish is calculated as the proportion of impaired reflexes, ranging from 0 (no impairment) to 1 (fully impaired, no reflexes present). The fish are then returned to their tank and held for a species-specific amount of time and monitored for delayed mortality. In the case of triggerfish, it was determined that one week was an appropriate time frame for monitoring, however it can be much longer in other species. The final step is developing a model to predict total mortality (immediate and delayed mortality) from impaired reflexes using logistic regression. The resulting curve is termed the RAMP curve.

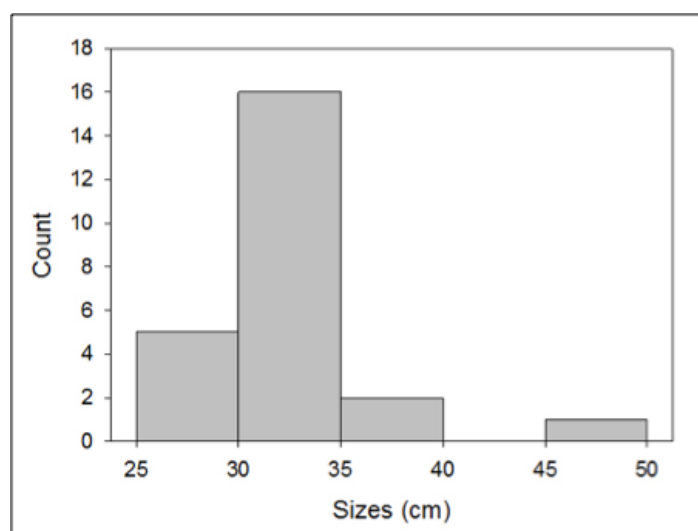

Figure 14. Size distribution of collected triggerfish

Baseline Tests

For the baseline tests, fish were individually taken by hand net from the stocking tank and were placed on a worktable. Reflexes were scored as present (0) or absent (1). If the investigator was unsure of the presence of a reflex, it was scored as absent. The fish were scanned with a Biomark tag reader and the tag number was noted. Preliminary investigations of appropriate reflexes identified six restrained and two free-swimming reflexes that were consistently present in unstressed control fish. The reflexes tested were body flexion unrestrained, body flexion restrained, head complex, operculum, dorsal spine reflex and vestibular-ocular reflex. The free-swimming reflexes tested were natural righting and evasion. The body flexion reflex unrestrained (Body Flex 1) was present if the fish exhibited spontaneous flexion on the worktable. Body flexion under restraint (Body Flex 2) was present if the fish flexed against the investigator's hand gently holding it to the worktable. The head complex reflex was present if the operculum flared and mouth opened regularly for 5 seconds. The operculum reflex was present if after the operculum was lifted with a probe, the operculum returned to the closed position. The dorsal spine reflex was present if after the first dorsal spine was lifted, the spine returned to the starting position (Figure 15). Triggerfish have the ability to lock this spine in place, if this occurred; the spine was released by pressing on the second dorsal spine, which releases the first dorsal spine. The reflex test was then conducted as described. The vestibular-ocular response was present if the fish tracked the investigator with its eye as it was rotated along the horizontal axis. After these six reflexes were evaluated the fish were then returned to a holding tank and the free-swimming reflexes were observed. The

natural righting reflex was present if the fish was able to right itself after returning to the water. The evasion response was present if the fish exhibited normal swimming activity and spontaneously swam when returned to the water. After all fish were tested, the fish were kept under observation in the holding tank for 7-days. Immediate or delayed mortality was noted, as were any signs of sub-lethal effects of stress such as lack of feeding, lethargy or signs of bacterial infection.



Figure 15. Dorsal spine reflex testing under restraint

Stress Tests

The main stressor suffered by fish during capture by a purse seine vessel is crowding while contained in the pursed net in the water. This can result in hypoxia and exhaustion as fish attempt to escape the net. Once on deck, the main stressor fish are exposed to is air-exposure (anoxia) which occurs while the catch and bycatch are being sorted. The length of time bycatch species may experience anoxia varies and depends on

both the vessel construction and the presence of other bycatch species, such as sharks and turtles that must be discarded first. Another potential stressor includes scale loss from contact with the net but this study did not specifically address this attendant stressor.

These stress tests dealt mainly with the single stressor of anoxia; however, the experimental fish also experienced some crowding. For all stress tests, the fish were crowded in the net for 5 minutes before being lifted out of the water. The fish were then placed in a cooler for the duration of the indicated air exposure. Baseline tests were conducted on all four groups of fish prior to air exposures. Air exposure tests began after the 7-day observation period following baseline reflex testing. Group I fish were exposed to the air for 4 min, 8 min, 12 min and 16 min with a 7-day period between air exposures. Group II and III fish were exposed to the air for 8 min as were group III fish. Group IV fish were exposed to the air for 16 min. After air exposure, all fish were returned to the stocking tank and removed one at a time for reflex testing as described in the baseline methods. Any immediate mortality was noted. The fish were then placed in the holding tank and monitored for seven days for delayed mortality and infection. The reflexes for each fish were summed and the average reflex impairment was calculated, giving each fish a single RAMP score for each air exposure.

Statistical Analysis

Differences between group's RAMP scores were examined using one-way analysis of variance (ANOVA), as were differences between group's mortality. Between group differences for both impaired reflexes and mortality were examined with post-hoc

testing using Tukey's HSD test. Groups were pooled together for all further analysis. Differences in reflex impairment after air exposure duration were found using one-way analysis of variance (ANOVA). The relationship between air exposure and impaired reflexes as well the relationship between impaired reflexes and mortality was described with sigmoid curves, $y = \frac{1}{1+e^{-\frac{(x-x_0)}{b}}}$, using group reflex scores and total mortality (delayed and immediate) and tested for significance with $F=MS_{\text{regression}}/MS_{\text{residual}}$ using SigmaPlot 10.0 software (Davis and Ottmar, 2006). Significance was set at $p=0.05$ for all tests.

A Bayesian logit model was developed to predict mortality in fish given both air exposure and reflex impairment. Mortality was modeled as survival (0) or mortality (1) with a Bernoulli distribution and the logit link function was used to transform the linear function:

$$Mortality(i) \sim Bernoulli(p(i))$$

$$logit[p(i)] = \log \frac{p(i)}{(1-p(i))} = \beta_1 + \beta_2 Air(i) + \beta_3 RAMP(i)$$

Equation 8

The model was run using R (version 3.1.1) with RStudio (versions 0.98) with the packages R2jags (version 0.5-6) and rjags (version 3-15). Normal uninformative priors were used for β_1 , β_2 and β_3 with initial values of 1.0, 0.0 and 0.0 respectively. The model was run with 2 chains and was allowed to run for 400,000 iterations with a burn-in of 100,000. Convergence was determined using the Gelman-Rubic diagnostic and an

examination of the posterior densities and autocorrelation lags. Model fits were assessed using differences in the Deviance Information Criterion (DIC), a generalization of Akaike's criterion (AIC) appropriate for Bayesian models (Lunn *et al.*, 2000). The predicted mortality for models using both air exposure and impaired reflexes (RAMP) as well with the single variables, air exposure and RAMP were compared to observed mortality. Model selection was based on the highest percentage of correctly predicted outcomes (survival ($p < 0.5$) vs. mortality ($p > 0.5$)) and the lowest Δ DIC value.

Results

Stress Tests

Reflex impairment increased significantly for all groups in response to air exposure with variability between reflex types (Figure 16). Stress testing for individual fish was completed in under 40 seconds and all reflex testing was completed in less than 9 minutes. No immediate mortality was seen at any air exposure in any of the groups. Delayed mortality occurred in one fish in group I at 16 minutes, in 2 fish at 8 minutes in group III and in 2 fish in group IV at 16 minutes (Table 9). The delayed mortality seen in groups III and IV was the result of a sudden and severe bacterial infection. There were no significant differences between groups' RAMP scores ($p = 0.191$) or between groups' delayed mortality ($p = 0.508$) (Table 11 and Table 12). Therefore, the groups were pooled for the remainder of the analyses. There were significant differences in reflex impairment between the baseline test (0 minutes) and 8 min. air exposure and between the baseline test and 12 min. exposure. There was also a significant difference between 16 min air

exposures and all other air exposure. The most commonly impaired reflex was body flexion under restraint followed by the vestibular-ocular response while evasion and natural righting were the least often impaired reflexes (Figure 17). There was a significant relationship between impaired reflexes and delayed mortality (Table 14).

Table 9. Mean (SE) proportions of individual reflex impairment for each group and air exposure (n)

Air Exposure (n)	Reflexes tested							
	Resistance 1	Resistance 2	Operculum	Head Complex	VOR	Dorsal fin	atural Rightin	Evasion
Group I								
0 min (5)	0.00 (0.00)	0.00 (0.00)	0.00 (0.00)	0.00 (0.00)	0.00 (0.00)	0.00 (0.00)	0.00 (0.00)	0.00 (0.00)
4 min (8)	0.38 (0.52)	0.25 (0.46)	0.38 (0.52)	0.00 (0.00)	0.13 (0.35)	0.25 (0.46)	0.00 (0.00)	0.00 (0.00)
8 min (8)	0.38 (0.52)	0.75 (0.46)	0.63 (0.52)	0.50 (0.53)	0.38 (0.52)	0.25 (0.46)	0.00 (0.00)	0.00 (0.00)
12 min (8)	0.13 (0.35)	1.00 (0.00)	0.25 (0.46)	0.38 (0.52)	0.75 (0.46)	0.38 (0.52)	0.00 (0.00)	0.00 (0.00)
16 min (8)	0.63 (0.52)	1.00 (0.00)	0.50 (0.53)	0.38 (0.52)	1.00 (0.00)	0.88 (0.35)	0.25 (0.46)	0.13 (0.35)
Group II								
0 min (6)	0.00 (0.00)	0.00 (0.00)	0.00 (0.00)	0.00 (0.00)	0.00 (0.00)	0.17 (0.41)	0.00 (0.00)	0.00 (0.00)
8 min (6)	0.00 (0.00)	0.67 (0.52)	0.17 (0.46)	0.34 (0.52)	0.50 (0.55)	0.17 (0.41)	0.00 (0.00)	0.00 (0.00)
Group III								
0 min (4)	0.00 (0.00)	0.00 (0.00)	0.00 (0.00)	0.25 (0.50)	0.00 (0.00)	0.17 (0.41)	0.00 (0.00)	0.00 (0.00)
8 min (5)	0.20 (0.45)	1.00 (0.00)	0.40 (0.55)	0.00 (0.00)	0.40 (0.55)	0.20 (0.45)	0.00 (0.00)	0.20 (0.45)
Group IV								
0 min (4)	0.00 (0.00)	0.00 (0.00)	0.00 (0.00)	0.00 (0.00)	0.00 (0.00)	0.00 (0.00)	0.00 (0.00)	0.00 (0.00)
16 min (4)	0.00 (0.00)	1.00 (0.00)	0.75 (0.50)	0.75 (0.50)	0.75 (0.50)	1.00 (0.00)	0.25 (0.50)	0.25 (0.50)

Table 10. Mean (SE) proportions of total reflex impairment and mortality for each group and air exposure (n).

Air Exposure (n)	Impaired Reflexes Mean (SE)	Delayed Mortality Mean (SE)
Group I		
0 min (5)	0.00 (0.00)	0.00 (0.00)
4 min (8)	0.17 (0.06)	0.00 (0.00)
8 min (8)	0.36 (0.04)	0.00 (0.00)
12 min (8)	0.36 (0.04)	0.00 (0.00)
16 min (8)	0.59 (0.04)	0.50 (0.19)
Group II		
0 min (6)	0.02 (0.02)	0.00 (0.00)
8 min (6)	0.23 (0.08)	0.00 (0.00)
Group III		
0 min (4)	0.04 (0.04)	0.00 (0.00)
8 min (5)	0.30 (0.12)	0.40 (0.25)
Group IV		
0 min (4)	0.00 (0.00)	0.00 (0.00)
16 min (4)	0.59 (0.11)	0.50 (0.29)

Table 11. Results of ANOVA between group reflex impairment

Source of Variation	DF	SS	MS	F	P
Between Groups	3	0.42	0.14	1.632	0.191
Residual	62	5.32	0.09		
Total	65	5.74			

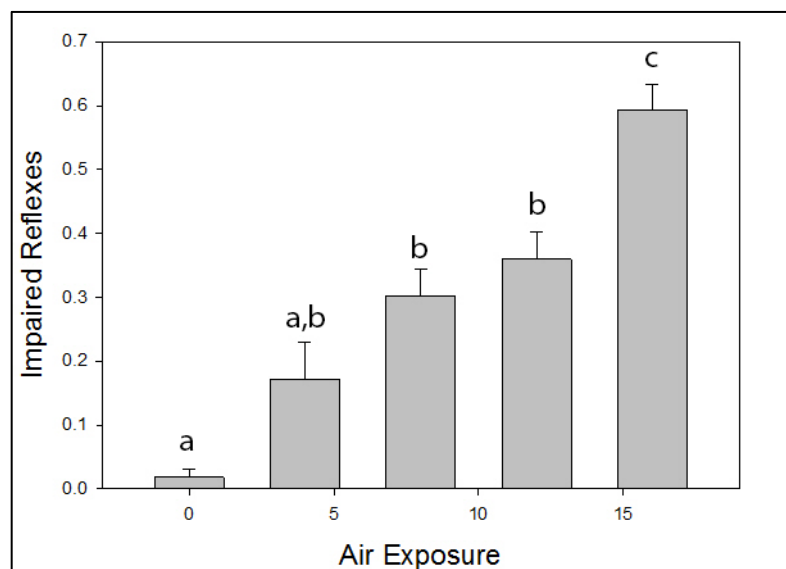

Figure 16. Mean proportion of impaired reflexes for all groups after air exposures. Error bars are standard errors of the mean. Data points are mean proportion for each group after air exposure. Letters represent significant difference in impaired reflexes after air exposure.

Table 12. Results of ANOVA between group mortality

Source of Variation	DF	SS	MS	F	P
Between Groups	3	0.30	0.10	0.78	0.51
Residual	62	7.96	0.13		
Total	65	8.26			

Table 13. Results of ANOVA between reflex impairments at air exposures of pooled groups.

Source of Variation	DF	SS	MS	F	P
Btn air exposures	4	2.66	0.67	36.22	<0.001
Residual	61	1.12	0.02		
Total	65	3.78			

Table 14. Results of ANOVA between mortality at impaired reflexes of pooled groups

Source of Variation	DF	SS	MS	F	P
RAMP Scores	8	2.84	0.36	7.27	<0.001
Residual	57	2.79	0.05		
Total	65	5.63			

The relationship between air exposure and impaired reflexes (n=11) was described by a sigmoid curve ($r^2=0.93$) and was statistically significant ($p<0.0001$) (Fig 18). The point at which half of the reflexes were impaired occurred at 13.8 minutes. The relationship between impaired reflexes and delayed mortality (n=22) and was described by a sigmoid curve ($r^2=0.72$) was statistically significant ($p=0.0006$) (Fig. 19). The point at which half the fish experienced delayed mortality occurred at 64% impaired reflexes (Figure 18 and Figure 19).

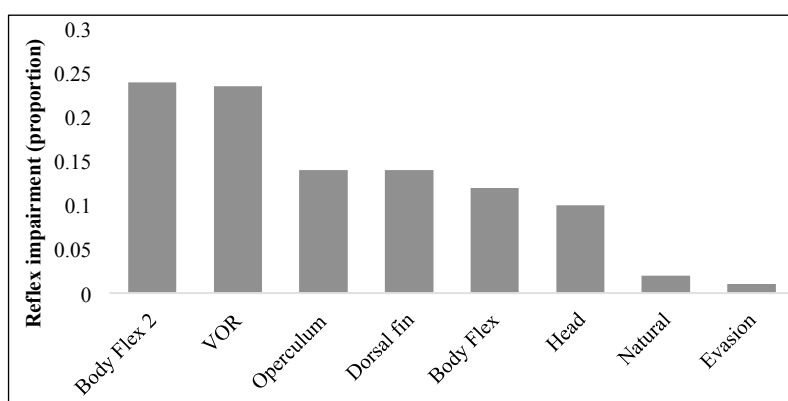

Figure 17. Proportional contribution of impairment to total RAMP score from each tested reflex for all groups and all air exposures.

Bayesian Model

The model with only impaired reflexes as an explanatory variable correctly predicted 92% of observed outcomes while the full model with both air exposure and impaired reflexes correctly predicted 89% of the observed survival and mortality. The impaired reflex model had the lowest Δ DIC (0.0) while the full model had a Δ DIC of 0.2 (Table 16). This small difference in DIC implied that the full model was also somewhat supported by the data (Burnham et al, 2002). The model containing only air as an explanatory variable had a larger Δ DIC of 3.8, however this model correctly predicted outcomes as well as the full model (89%).

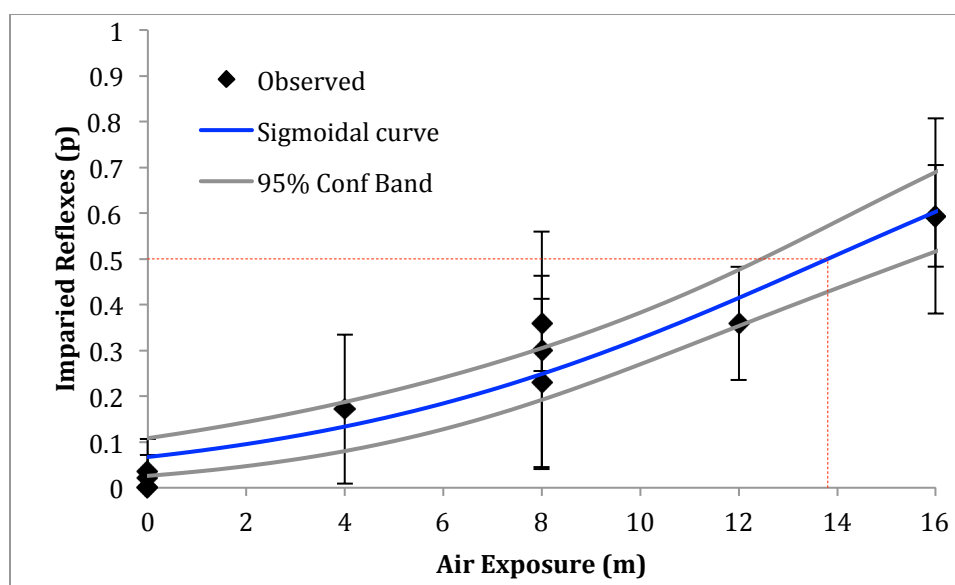

Figure 18. Relationship between air exposure (m) and impaired reflexes with 95% confidence band.

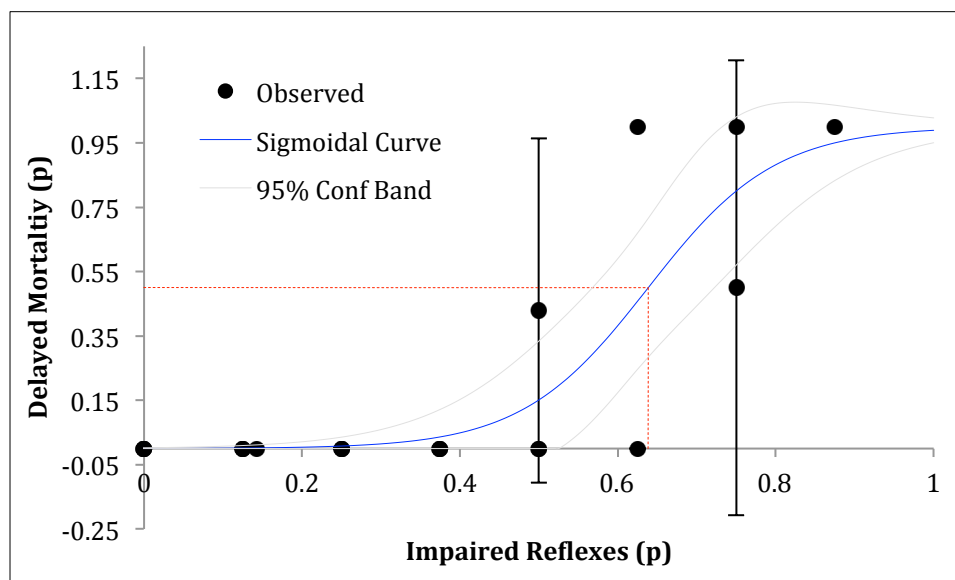

Figure 19. Relationship between impaired reflexes and delayed mortality.

Table 15. Bayesian model results with mean effect of parameters on mortality and credible intervals. Rhat value of 1.00 shows model has converged and n.eff is the effective sample size for each parameter, which should be more than ~ 500 (Lunn ref).

	Mean	SD	2.50%	50%	97.50%	Rhat	n.eff
Model: Air, RAMP							
Intercept	-11.52	3.94	-20.88	-10.95	-5.48	1.00	1300
Air	0.32	0.21	-0.05	0.30	0.79	1.00	2500
RAMP	10.80	4.82	2.41	10.38	21.46	1.00	3700
Model: Air							
Intercept	-8.71	2.90	-15.54	-8.27	-4.32	1.00	2400
Air	0.54	0.20	0.23	0.51	0.99	1.00	3500
Model: RAMP							
Intercept	-8.04	2.37	-13.57	-7.73	-4.32	1.00	28000
RAMP	12.48	4.10	5.88	11.99	21.89	1.00	28000

Table 16. Model selection results, correct shows correctly predicted outcomes. Model with sole variable of RAMP score selected as best model.

Model	DIC	Δ DIC	Correct
Air,RAMP	28.1	0.2	89%
RAMP	27.9	0	92%
Air	31.7	3.8	89%

Discussion:***Stressors***

There was no immediate mortality in the four groups at any air exposure interval, including 16 minutes of air exposure. However, with the significant increases in impaired reflexes observed, it is very likely in the fishery there will be higher levels of mortality due to predation and sinking in the water column. The laboratory component only tested a single stressor and it has been observed that multiple stressors can have a compounded effect on mortality (Olla *et al.*, 1995). With purse seining, the stressors involved can include: exercise stress, crowding, hypoxia/anoxia, and crushing as well as scale damage. During normal fishing operations, a net is deployed (<100 m in depth) to encircle the school of target fish and any associated species. When the net has completely surrounded the fish, the bottom is “pursed” to prevent fish from escaping; the net is then slowly hauled up to the vessel. If fish are at the bottom of the net and are brought to the surface, they can experience barotrauma, particularly if they possess a swim bladder like triggerfish. The species contained within the net will experience crowding and most likely hypoxic conditions. A study examining stress reactions in sardines (*Sardina pilchardus*) during purse seine operations found survival rates were most dependent on the amount of time fish were restrained in the net (Marçalo *et al.*, 2006). Once the net has been pulled in to a sufficiently small diameter, a scoop or brailer (holding up to 5-10 tons of fish) is lowered over the side of the vessel to pick up the fish and deposit them into the hold, potentially resulting in scale loss and crushing. Any bycatch that is to be discarded

is sent overboard either in a chute out of the side of the vessel or from above decks, possibly causing further contusions and scale loss. The same study on purse seine caught sardines found the most common injury and cause of subsequent mortality was scale loss (Marcalo *et al.*, 2010; Marçalo *et al.*, 2006) most likely incurred during the brailing process or when the purse seine was brought close to the vessel. Triggerfish have smaller, tightly connected scales, so presumably scale loss would be less extreme. However, triggerfish have been observed with extensive scarring at FADs so scale loss does occur during fishing activities (Ménard *et al.*, 2000).

The stressors experienced by species in the laboratory are not on the scale seen in the actual fishing operations and it is reasonable to expect a greater amount of immediate mortality in fisheries than is observed in the laboratory. Only one species of Balistidae was tested and there are two other species of triggerfish common to FADs. However, due to the similar morphology and physiology of Balistidae species it is expected that similar patterns of impaired reflexes would be present under fishery conditions.

The time to when half the reflexes were impaired occurred at an air exposure of 13.81 minutes, and bycatch species can be kept onboard for up to 30 minutes before they are discarded. However, this is generally at the higher end of time onboard and can occur when more sensitive species are inadvertently captured, such as sharks and turtles. If the fish are discarded before the time to half impairment, there is a reasonable chance of survival as 50% mortality occurred with 64% of the reflexes impaired. However, this must of course be investigated under fishery conditions.

The most often impaired reflexes with triggerfish were the body flexion under restraint and vestibular-ocular reflex while natural righting and evasion were the least impaired. Measuring a wide-ranging suite of reflexes allows for different physiological systems to be examined. The most commonly impaired reflexes may not be as integral towards survival as the least often impaired reflexes. For the reflexes tested out of the water, these included the operculum and head complex reflexes, which are associated with breathing and coughing behaviors, both necessary to survival. Previous studies have observed that behaviors associated with high survival value were most often the first reflex to return after impairment (Olla et al, 1995).

Experiments in this study were conducted in the laboratory setting and did not include the presence of predators; impaired reflexes can have a direct effect on predator evasion as well as obtaining prey. Recovery from the stressor and the impaired reflexes can take up to 24 hours as seen with coho salmon (*Orcorhynchus kisutch*) which experienced significant levels of predation 4 hours after the stressor (Olla *et al.*, 1995). The tuna fishery operates in the open ocean and triggerfish with impaired reflexes have the potential to sink out their optimum environment into deeper waters. The most commonly impaired reflex of vestibular ocular response can detrimentally impact both predator evasion and feeding activities while lack of body flexion may negatively affect swimming speeds (Davis, 2010).

There have been no studies as of yet examining survival of teleost bycatch survival *in situ* with the tuna purse-seine fishery, however other purse-seine fisheries have been studied. Marçalo et al (2009) studied the physiological impacts of purse-seine

capture on sardines (*Sardina pilchardus*) in Portugal. This study examined whether simulated purse seining would prompt similar physiological responses to those found in actual fishing operations and found hematocrit and cortisol levels were similar to what was seen in the field. The authors noted that cortisol concentrations did not correlate to long-term survival, consistent with the results of Davis (2001); survival was modeled as a function of the fishing operation duration, water temperature, fish density and fish weight, not blood plasma variable concentrations.

Previous studies utilizing the RAMP methodology found that air exposure was the most significant predictor of delayed mortality, however it was often used in combination of stressors, such as tow duration and air exposure (Humborstad *et al.*, 2009). The addition of forced swimming and net abrasion with air exposure in cod (*Gadus morhua*) did not significantly increase either reflex impairment or mortality above what was seen with just air exposure. It is reasonable to assume that air exposure will have the most profound effect on teleost species due to their morphological and physiological make-up; however, stressors can act synergistically to have an even greater effect on long-term survival outcomes. Further studies on the compound stressors in the purse-seine fishery will be conducted during normal fishing operations.

Delayed mortality after discard can be attributed to stress, predation, anoxia and injury from the fishing gear. This mortality can be broken down into three temporal classifications, immediate mortality, short-term mortality and long-term mortality (Pollock and Pine, 2007). Immediate mortality results from the actual fishing operation or stressor and was not observed during this study. Short-term mortality occurs within 24-72

hours after release and can be considered a result of either handling injury or indirect effects such as exhaustion. This short-term mortality only occurred in one individual after 16-minute air-exposures. Long-term mortality occurs after 72 hours and can be the result of injuries that could impair feeding behavior, predator avoidance or increase diseases susceptibility (Pollock and Pine, 2007). This can be mirrored in the integrated stress response in teleosts that is grouped into three types of responses, primary, secondary and tertiary. The primary response occurs when the brain perceives the stressor and stimulates the release of catecholamines and cortisol, which then in turn elicit different responses. These responses depend on the target cells and type of stress, termed the secondary stress response and includes increased cardiac output and oxygen uptake. The tertiary response is the whole-animal response to stress in terms of reduction in reproduction and growth, and immunosuppression which can potentially diminish the animal's capacity to withstand any additional stressors (Barton, 2002; Wendelaar Bonga, 1997). Immunosuppression experienced during stress is often associated with a decrease to disease suppression from both opportunistic bacterial and parasitic infections. The delayed mortality observed in this study was the result of severe infection and immunosuppression that has also been noted in sablefish (*Anoplopoma fimbria*) exposed to capture-related stressors (Lupes *et al.*, 2006).

In the case of hypoxia/anoxia stressors, the return to normoxic conditions can trigger a burst of reactive oxygen species (ROS) (Lushchak and Bagnyukova, 2006). These ROS can cause cellular damage across different cell types and tissues, particularly

an increase in cellular membrane rigidity. This compromises the function of the cells that can lead to long-term mortality or loss of fitness, particularly in fish that can survive the capture and discard process, such as Balistidae species.

The changes in feeding behavior, reproduction, immunosuppression and growth can have long-term effects not only on the individual but the overall structure of the population. Bycatch species, particularly *Balistes capriscus* and *Canthidermis maculate*, are associated with networks of FADs in the Eastern Atlantic for several months to years; the continual stress of purse seine vessels operating around FADs can create a reduction in overall fitness of the population (Taylor *et al.*, 1986).

Model Uses

The model with impaired reflexes as a descriptive variable has support from both the low Δ DIC and predicted outcomes; additionally it has best applicability for use in the field because air exposure may not always be easy to precisely measure for each individual fish. Onboard observers are generally below decks and the amount of time fish have been out of the water is difficult to determine. Using the single, easily calculated value of proportion of impaired reflexes allows for total delayed mortality to be estimated during fishing operations. This method can also help inform managers and observers of best practices for handling bycatch to ensure the highest rates of survival. The constraint to this approach is the baseline reflexes need to be established in unstressed individuals for each species of interest.

The Bayesian modeling approach was used in this study because of the low sample sizes obtained due to difficulties that arose from collecting fish sourced from the wild. In future experiments, the results from this study can be used to develop informed priors for a more robust Bayesian model.

Conclusions

The triggerfish in the study did not experience high levels of mortality, which suggests that they may be resilient enough to survive the single stressor of air exposure. While the stressor simulated in the laboratory setting cannot come close to the intensity experienced during the actual fishing operation, the basic biology and physiology of the fish do not change from laboratory to field settings (Davis, 2007). Furthermore the laboratory estimates of survival can always be considered as minimum estimates because they consider only one stressor, air exposure. The reflexes observed in the laboratory setting should be valid during fishing operations. Further reflex impairment studies are planned onboard commercial purse-seine vessels undergoing regular fishing operations. Using the estimates of the predicted mortality, total mortality will be estimated for the discarded triggerfish. These estimates will be validated using the same methods described in this paper using tanks onboard purse-seine vessels. The initial results of this study appear to show that anoxia alone does not cause large amounts of mortality for periods of exposure of up to 16 minutes, however several other acute stressors exist in the fishery and further studies will need to be conducted.

Supplementary Figures:

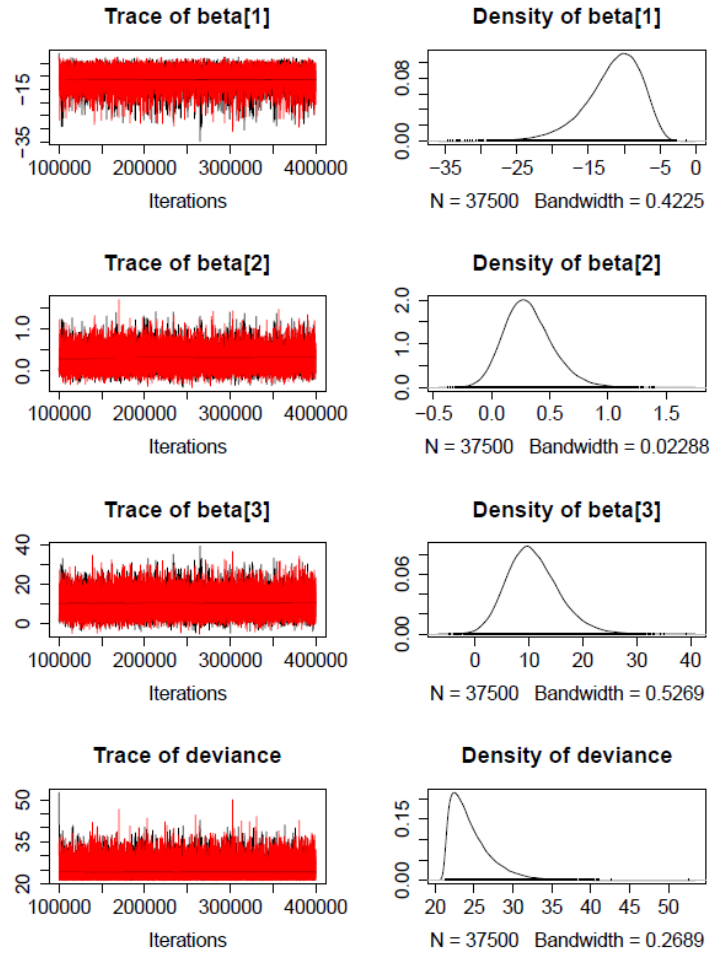

Figure 20. Trace and posterior distribution of full model (beta[2] (Air) and beta[3] (RAMP))

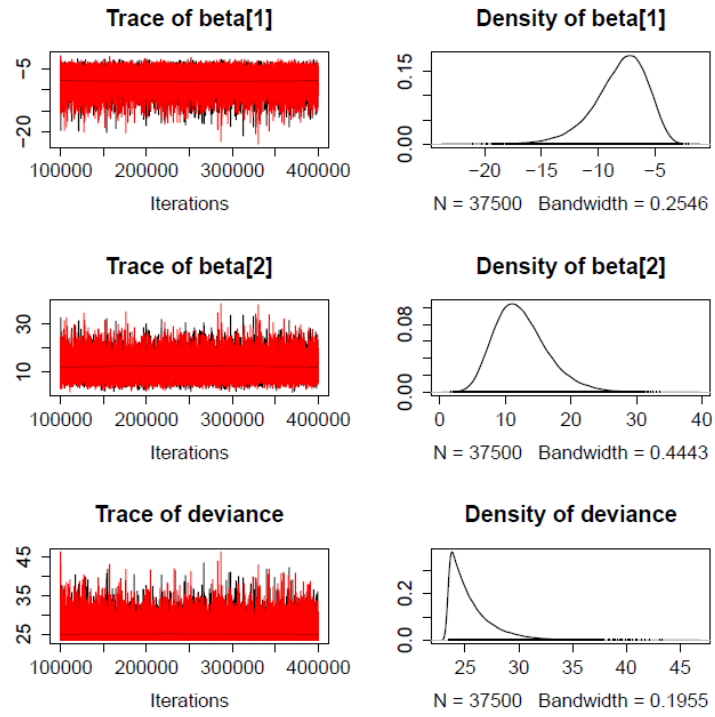

Figure 21. Trace and posterior distribution of model using impaired reflexes ($\beta[2]$ (RAMP))

Chapter 4: Impaired reflexes as measure of delayed mortality in recreationally caught yellowtail snapper (*Ocyurus chrysurus*)

Overview

Yellowtail snapper (*Ocyurus chrysurus*) are an important part of the reef fish assemblage in the western, tropical Atlantic and are caught by both recreational and commercial fisheries in South Florida and the Bahamas (Saillant *et al.*, 2012). The majority of the yellowtail snapper caught in the US comes from Florida waters and this species has supported an important fishery since the 1890's (Muller *et al.*, 2003). To sustain this fishery, there has been a minimum catch at size in effect for yellowtail snapper since 1983. The regulation requires any fish caught below 12 inches (30 cm) must be discarded in both the commercial and recreational fisheries. While minimum size limits aim to protect the long-term health of the stock by keeping sexually immature fish in the environment (Bohnsack, 2000), the stress of angling can result in either immediate or delayed mortality in fish that initially survive (Campbell *et al.*, 2010; Danylchuk *et al.*, 2014; Gingerich *et al.*, 2007; Stephen and Harris, 2010). It is estimated that 80% of snapper caught within southeastern Florida waters are discarded (Bartholomew and Bohnsack, 2005). To date, there have been no studies to assess the post-release mortality of yellowtail snappers discarded due to minimum size limits. Lack of information on post-release survival rates creates uncertainty in estimating the total impact of the fishery and the status of an economically and ecologically important reef fish population (Gilman *et al.*, 2013; Punt *et al.*, 2006). The management success of catch and release with respect to minimum size limits depends upon the long-term survival of the discarded fish.

Previous studies of catch and release fisheries found the majority of fish experienced delayed mortality, rather than immediate mortality (Gingerich *et al.*, 2007; Suski *et al.*, 2007).

Traditional methods of determining post-release survival of discarded fish include costly tagging experiments or measuring stress hormone concentrations in blood samples. Tagging experiments are often not logistically feasible due to economic constraints and the tag and tagging process can act as an additional stressor on the tagged fish (Pollock and Pine, 2007). The usefulness of blood parameters associated with the stress response to predict mortality can vary as concentrations fluctuate widely among species as well as individual fish within the same species (Raby *et al.*, 2012). Testing a whole animal response to stress, such as a suite of involuntary reflexes, has been demonstrated to be an effective way to determine long-term mortality (Danylchuk *et al.*, 2014; Davis, 2010; Humborstad *et al.*, 2009). The reflex action mortality predictor curve has been used by several fisheries for both teleosts and crustaceans to predict the fate of these species after being discarded from fishing activity (Davis, 2010, 2007; Raby *et al.*, 2012; Stoner, 2012).

The reflex action mortality predictor curve, first introduced by Davis, is a relatively new method to assess survival (Davis, 2010). This current study pairs reflex testing with measurements of traditional blood physiology parameters associated with the teleost stress response. However, due to field conditions inherent in fishing, traditional laboratory testing is not feasible. Portable point of care (POC) devices, for example i-STAT, have been gaining in popularity for use in the field in recent years as they allow

for instantaneous reading of blood parameters without requiring cumbersome laboratory equipment and specially trained personnel (Danylchuk *et al.*, 2014; Gallagher *et al.*, 2010). These devices are configured toward clinical use and the measurements and algorithms used are not calibrated for teleost red blood cells. Differences in the size and structure of red blood cells can bias measurements taken by these potentially very useful devices. Validation studies have been conducted with point of care devices and traditional laboratory assays with mixed results (Harter *et al.*, 2014; Stoot *et al.*, 2014), however, with validation, these devices can provide substantial benefits in understanding physiological parameters in field settings (Gallagher *et al.*, 2010).

This study pairs several methods to assess the post-release mortality of undersized yellowtail snapper. Impaired reflexes in response to air exposure were assessed and used to predict delayed mortality. Additionally, blood samples were taken and measured using an i-STAT and compared to impaired reflexes and delayed mortality. To test the accuracy of the i-STAT, traditional laboratory assays were conducted and compared to measurements obtained with the i-STAT.

Methods

Collection and Holding

Fish were collected from shallow water patch reefs in near shore waters of Cape Eleuthera, Eleuthera, The Bahamas (24.54°N 76.12°W). The fish were caught using naturally baited light circle hooks on a rod and reel. Only fish that were mouth-hooked were retained, all others were discarded after de-hooking. Fish were transported back to the Cape Eleuthera Institute (CEI) and held in 3,600 L flow through tanks continuously supplied with fresh seawater. Fish were allowed to recover and were monitored for

several days. Fork length was measured (Figure 22) and all fish were tagged with Biomark® 12 mm passive integrated transponder tags (Biomark®), tag locations were treated with a topical Betadine spray before being returned to the holding tanks.

Fish were randomly separated into four groups (Table 17). All groups of fish were held in two separate stocking tanks with the same water source. Separate tanks were necessary to maintain optimal stocking densities. For all tests, including baseline reflex testing and air exposures, fish were returned to two separate holding tanks. All four tanks, two stocking tanks and two holding tanks, received the same water supply through a splitter and had the same flow rates. Groups of fish were randomly assigned tanks and fish were identified through their individual PIT tag number for the duration of the experiment. Water temperatures ranged from 24.5 to 29°C, depending on the time of day, and dissolved oxygen within the tanks was ranged from 6.5 mg/L to 7.5 mg/L.

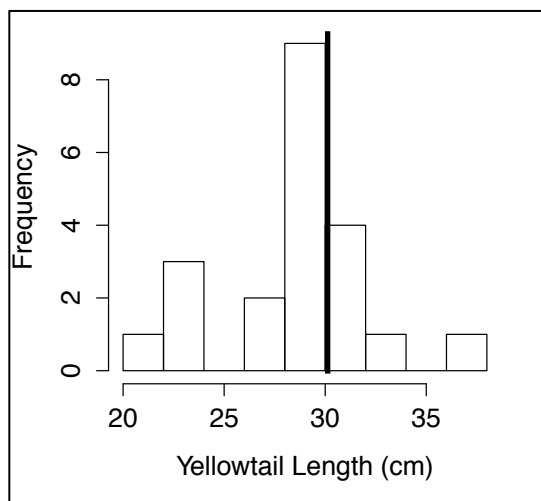

Figure 22. Distribution of size classes (average length 28.8 cm, median 29 cm). Black line signifies minimum size allowed in US territorial waters (30 cm)

Reflex and Stress Testing

Reflexes were identified that were present in all unstressed, control fish. The reflexes tested in restrained fish included vestibular-ocular response (VOR), head complex, mouth, and body flexion. Reflexes were scored as either present (0) or absent (1), not on the strength of the reflex response. If there was uncertainty that the reflex was present, it was scored as absent. VOR was noted as present when the fish was rotated laterally and the eye rotated in the socket and remained fixed on the investigator. Head complex was present when the fish exhibited rhythmic movements of mouth gape and operculum flare for 5 seconds. The mouth reflex was present if the mouth returned to the closed position after being opened with a probe. The reflex was present for body flexion if the fish flexed on a flat surface. The remaining reflexes were all tested in the water and consisted of the tail grab and equilibrium. The fish were placed in the tank upside down and if the fish returned to an upright position, the equilibrium reflex was scored as present. Once upright, the investigators lightly grasped the caudal fin and if the fish attempted to burst-swim away, the reflex was marked as present.

Once appropriate reflexes were identified in unstressed fish, fish were exposed to air in 2.5-minute intervals, up to 8 minutes. Individual fish were removed from the stocking tanks and exposed to the air by being placed in a foam-lined container. At the completion of the air exposure, reflexes were tested in the following order: body flexion, mouth reflex, head complex, and vestibular ocular reflex. Fish were then returned to holding tanks and the equilibrium reflex was tested followed by the tail grab. Fish were then monitored for 7 days for delayed mortality. PIT tag numbers and signs of infection were noted during the air exposure.

The proportion of impaired reflexes for each fish was found through the total impaired reflexes divided by the count of all tested reflexes. Delayed mortality was scored as survival (0) or delayed mortality (1). Group averages of impaired reflexes and delayed mortality were also calculated. The proportional contribution of each reflex towards total impaired reflex score was found through the average of the each impaired reflex divided by the sum of all impaired reflex averages (Davis, 2010).

Table 17. Numbers of fish within each group and total numbers of fish tested at each exposure.

Group	Air Exposure (m)						Total
	0	2.5	3	4	5	8	
I	7				2	3	12
II	3	2	2		1		8
III	4		4				8
IV		3		3			6
Total	14	5	6	3	3	3	34

Blood Sampling

Blood was drawn from a sub-sample of fish prior to reflex testing via a caudal puncture with a heparinized syringe. Whole blood measurements were performed using the VetScan i-STAT 1 (Abaxis, Union City, CA, USA) with the i-STAT CG4+ and i-STAT CG8+ cartridges. CG4+ cartridges measured: pH, pCO₂, pO₂, BE_{ecf}, HCO₃, TCO₂, sO₂, and lactate concentrations. CG8+ cartridges measured: pH, pCO₂, pO₂, BE_{ecf}, HCO₃, TCO₂, sO₂, Na⁺, K⁺, intracellular calcium (iCa), glucose, hematocrit and hemoglobin. Cartridges were stored in the dark in their original packaging at 2°C. Before testing, the cartridges were allowed to equilibrate to the ambient temperature of 28°C. Whole blood

was first measured with the CG4+, followed by the CG8+. Blood gases and pH measurements were taken from the CG4+ cartridges. The remainder of the blood samples were centrifuged and the resulting plasma was frozen and stored at -20°C.

Laboratory Testing

Frozen plasma was thawed at the University of Miami and lactate and glucose assays run, as well as analysis of Na⁺ and K⁺ using atomic absorption flame spectrometry. The concentration of lactate was measured using a commercial lactate assay kit (Sigma-Aldrich Co.). Glucose concentration in the plasma was measured using a glucose assay kit (Sigma-Aldrich Co.).

Statistical Analysis

The proportion of impaired reflexes for each fish in response to air exposure were fitted to a linear regression model and individual fish's mortality (delayed or immediate) were fitted to a binomial generalized linear model with a logit link. The relationship between air exposure and average impaired reflexes in groups as well the relationship between impaired reflexes and mortality was described with biphasic, sigmoid curves:

$$f = \frac{1}{\left(1 + e^{-\frac{x-x_0}{b}}\right)}$$

Equation 9

using average reflex scores and average total mortality (delayed and immediate) and tested for significance with $F = MS_{\text{regression}}/MS_{\text{residual}}$ using SigmaPlot 10.0 software (Davis and Ottmar, 2006). Significance was set at $p=0.05$ for all tests.

The correlations between impaired reflexes, air exposure, delayed mortality and whole blood physiological parameters determined by the i-STAT were measured using Pearson correlation with a significance levels of $p=0.05$. Variables that were significantly correlated were included in two generalized linear models, one to predict delayed mortality and the other to predict impaired reflexes. For individual fish, a binomial GLM model was used with a logit link to predict mortality. Significant variables were identified with stepwise regression by AIC using the MASS package in R (Venables and Ripley, 2002).

Measurements taken by the i-STAT were compared to results obtained from the traditional laboratory assays of lactate and glucose concentrations as well as for Na^+ and K^+ using regression analysis. Unless otherwise noted, all data analysis was completed through RStudio (RStudio Team, 2015) and R programs (R Development Core Team, 2008).

Results

Reflex and Stress Testing

The reflex most frequently impaired in yellowtail snapper was equilibrium, righting reflex upon being returned to the water, followed by the tail grab response (Figure 23). The vestibular ocular reflex and the head complex reflex were always present in the tested fish.

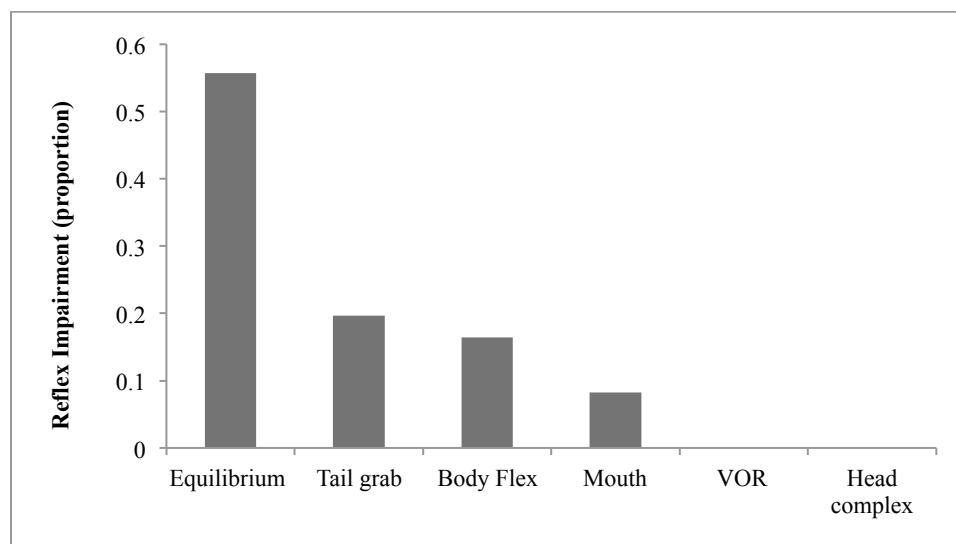

Figure 23. Proportional contribution of each impaired reflex.

The relationship between air exposure and impaired reflexes for individual fish was significant (<0.0001 ; Table 18 and Figure 24). At 4.68 minutes, 25% of the reflexes were impaired in the tested fish. The air exposures only extended to 8 minutes, however if the model correctly predicts reflex impairment in response to air exposures, 50% of reflexes would be impaired at 9.72 minutes of air exposure. The results from individual fish are comparable to the results obtained from group averages. The group averages were fitted to a sigmoidal function, rather than a linear model, however 25% of the reflexes were impaired at 4.88 minutes of air exposure. The relationship between air exposure and average impaired reflexes was significant ($p=0.002$; Table 18).

Table 18. Model results of air exposure on impaired reflexes in individual fish and group averages.

Response: Impaired reflexes (individual)					
	Df	Sum Sq	Mean Sq	F value	Pr(>F)
Air	1	0.40	0.40	19.42	<0.0001
Residuals	29	0.60	0.02		
Coefficients linear model					
	Est.	Std. Error	t value	Pr(> t)	
(Intercept)	0.02	0.04	0.43	0.67	
Air	0.05	0.01	4.41	0.00	
DF	29.00				
Adj R2	0.38				
Response: Impaired reflexes (average)					
	Df	Sum Sq	Mean Sq	F value	Pr(>F)
Regression	1	0.15	0.15	18.13	0.002
Residual	9	0.07	0.01		
Coefficients sigmoidal model					
	Est.	Std. Error	t value	Pr(> t)	
a	1.00	0.00	(+inf)	<0.0001	
b	3.49	0.95	3.66	0.01	
x₀	8.46	1.21	6.96	<0.0001	

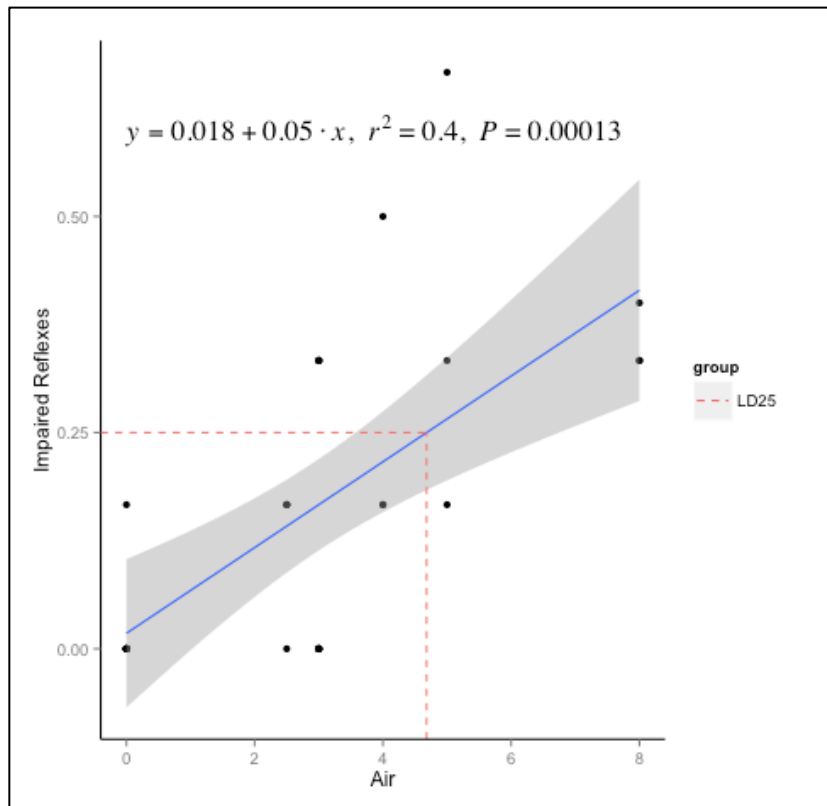

Figure 24. Linear regression model fitted to air exposure (minutes) and impaired reflexes (proportion). Points are individual fish impaired reflex scores at given air exposures. Red dashed line represents air exposure at which 25% of reflexes become impaired. Gray area around fitted line represents 95% confidence interval ($p=0.00013$, $n=30$)

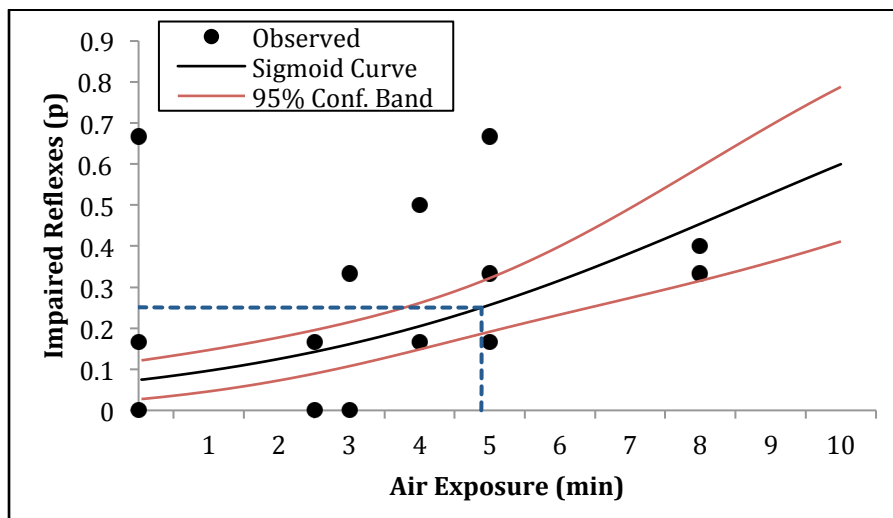

Figure 25. Impaired reflexes predicted by air exposure fitted to sigmoidal curve and 95% confidence interval.

The relationship between impaired reflexes and delayed mortality for individual fish was not significant, ($p=0.063$, $n=30$; Table 19, Figure 27), however the average mortality given average impaired reflexes within groups was significant ($p=0.019$, $n=11$, Table 19, Figure 27).

Table 19. Model results of proportion of impaired reflexes (RAMP) on delayed mortality in individual fish and group averages.

Response: Delayed mortality (individual)					
	Est.	Std. Error	t value	Pr(> t)	
(Intercept)	-1.54	0.62	-2.5	0.01	
RAMP	4.40	2.37	1.86	0.06	
Response: Delayed mortality (averages)					
	DF	SS	MS	F	P
Regression	1	0.9032	0.9032	7.666	0.019
Residual	10	1.1782	0.1178		
Coefficients (averages)					
	Est.	Std. Error	t value	Pr(> t)	
a	1	0	(+inf)	<0.0001	
b	0.16	0.10	1.71	0.12	
x0	0.26	0.08	3.13	0.01	

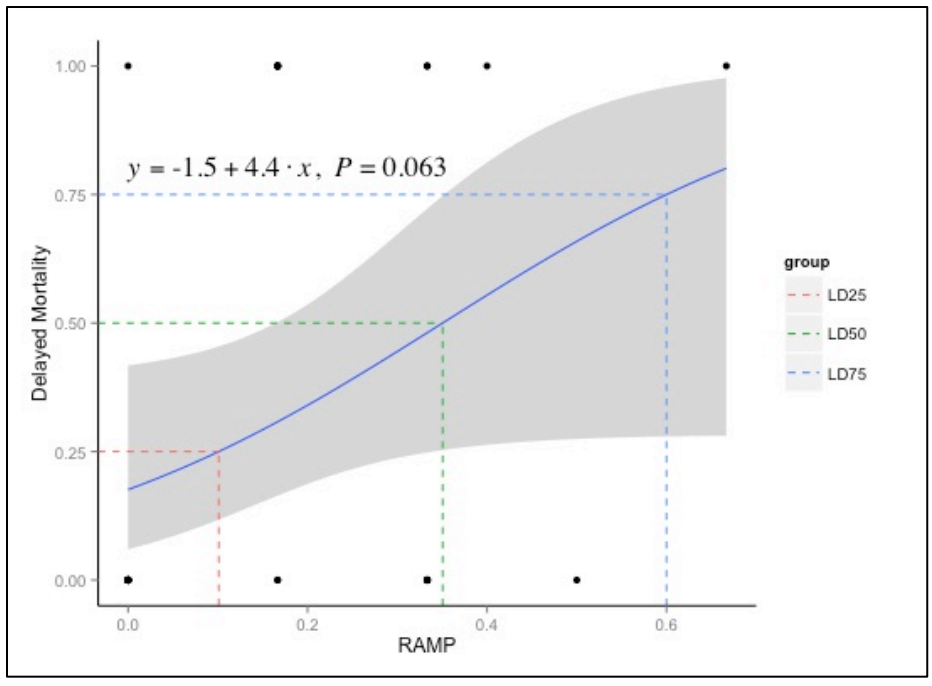

Figure 26. Results of generalized linear model (binomial with logit link) on individual fish's reflex scores (RAMP scores) and delayed mortality. Lethal doses of impaired reflexes are noted with dashed lines (LD25, LD50 and LD75). Gray area around fitted line represents 95% confidence interval (p=0.063, n=30).

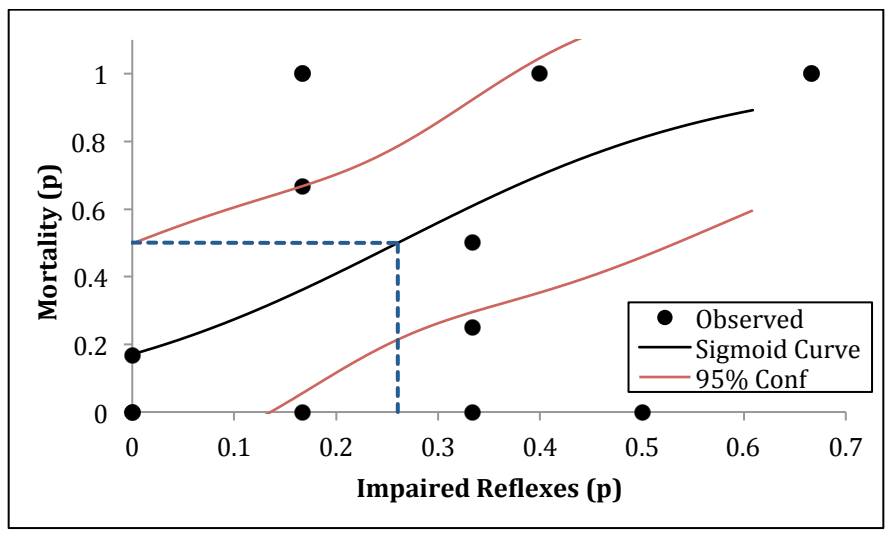

Figure 27. Proportion of delayed mortality predicted by impaired reflexes fitted to sigmoidal curve and 95% confidence interval. Dashed blue line point at which impaired reflexes result in 50% delayed mortality.

i-STAT Measurements

Physiological parameters obtained through the subsample of fish that were significantly correlated to impaired reflexes were air exposure, pH, and base excess (BEecf). Whereas air exposure, pH, base excess (BEecf) and lactate concentration were significantly correlated with delayed mortality (Figure 7). The linear regression model to predict delayed mortality was significant for air exposure but the model selected through the AIC stepwise regression contained only pH level (Table 20) as a significant predictor. The linear regression model to predict delayed mortality had base excess and lactate as significant predictors (Table 21). Blood sampling did not have a significant effect on mortality (Table 22).

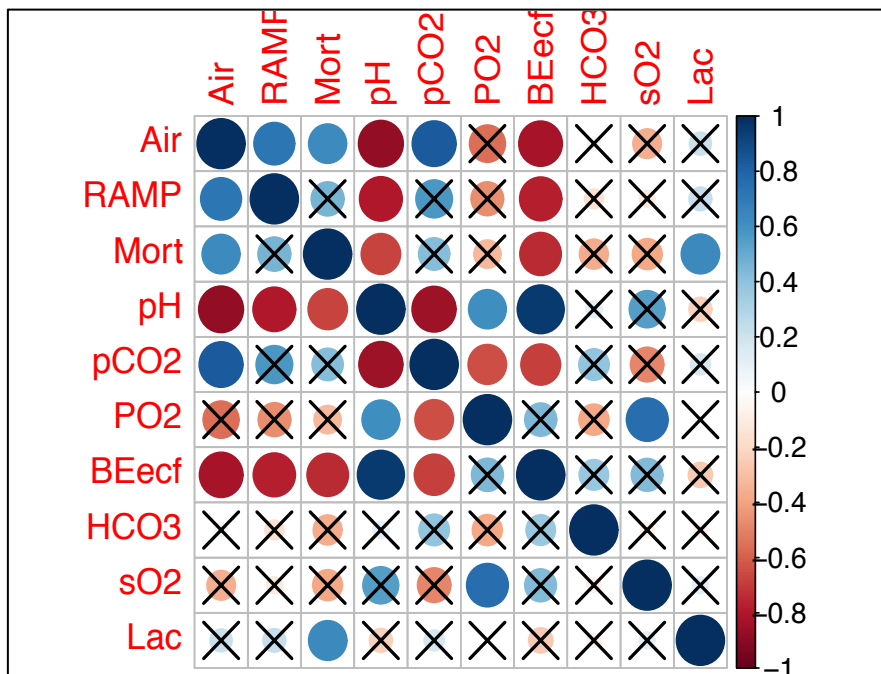

Figure 28. Results of Pearson Correlation between air exposure, impaired reflex score (RAMP), and delayed mortality. Variables that are not significant ($p > 0.05$) are crossed out.

Table 20. Summary of results from linear regression model predicting impaired reflexes using i-STAT parameters and air exposure. Model 1 is the complete model and Model 2 is preferred by the AIC.

Model 1 - Response: Impaired reflexes					
	Df	Sum Sq	Mean Sq	F value	Pr(>F)
Air	1	0.12	0.12	8.59	<0.05
pH	1	0.03	0.03	1.83	0.23
BEecf	1	0.00	0.00	0.05	0.83
Lac	1	0.00	0.00	0.02	0.89
Residuals	6	0.09	0.01		
Coefficients:					
	Est.	Std. Error	t value	Pr(> t)	
(Intercept)	3.37	7.73	0.44	0.68	
Air	0.01	0.05	0.26	0.80	
pH	-0.48	0.93	-0.52	0.62	
BEecf	-0.01	0.05	-0.21	0.84	
Lac	0.00	0.02	0.14	0.89	
Adj R ²					
Model 2 - Response: Impaired reflexes					
	Df	Sum Sq	Mean Sq	F value	Pr(>F)
pH	1	0.15	0.15	15.18	<0.05
Residuals	9	0.09	0.01		
Coefficients:					
	Est.	Std. Error	t value	Pr(> t)	
(Intercept)	5.68	1.39	4.08	<0.05	
pH	-0.77	0.20	-3.90	<0.05	

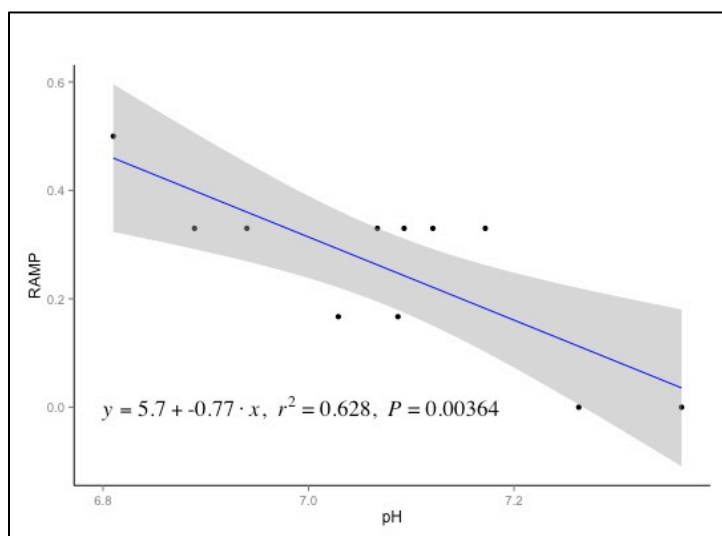

Figure 29. Linear regression model fitted to pH levels and impaired reflexes (RAMP) and 95% confidence interval (gray area).

Table 21. Summary of results from linear regression model predicting delayed mortality using i-STAT parameters, impaired reflexes and air exposure.

All variables - Response: Delayed mortality					
	Df	Sum Sq	Mean Sq	F value	Pr(>F)
RAMP	1	0.60	0.60	6.03	0.06
Air	1	0.47	0.47	4.74	0.08
pH	1	0.22	0.22	2.18	0.20
BEecf	1	0.37	0.37	3.73	0.11
Lac	1	0.58	0.58	5.90	0.06
Residuals	5	0.49	0.10		
Coefficients:					
	Est.	Std. Error	t value	Pr(> t)	
(Intercept)	-14.56	20.51	-0.71	0.51	
RAMP	-0.98	1.07	-0.92	0.40	
Air	0.07	0.12	0.55	0.60	
pH	1.32	2.48	0.53	0.62	
BEecf	-0.21	0.13	-1.63	0.16	
Lac	0.10	0.04	2.43	0.06	
Adj R²	0.64				
Selected variables - Response: Delayed mortality					
	Df	Sum Sq	Mean Sq	F value	Pr(>F)
BEecf	1	1.51	1.51	19.14	<0.05
Lac	1	0.58	0.58	7.38	<0.05
Residuals	8	0.63	0.08		
Coefficients:					
	Est.	Std. Error	t value	Pr(> t)	
(Intercept)	-3.09	0.87	-3.55	<0.05	
BEecf	-0.12	0.04	-3.54	<0.05	
Lac	0.10	0.04	2.72	<0.05	
Adj R²	0.71				

Table 22. Results of binomial GLM predicting mortality given air exposure, impaired reflexes or blood sampling.

Coefficients:				
	Estimate	Std. Error	z value	Pr(> z)
(Intercept)	-1.34	0.68	-1.98	0.05
Blood	-0.60	0.91	-0.66	0.51
RAMP	5.00	2.69	1.86	0.06
Air	0.34	0.26	1.31	0.19

i-Stat Validation

The blood plasma parameters that were successfully tested in the laboratory were lactate, glucose, Na⁺ and K⁺ concentrations. The linear regression model for the relationship between the glucose assay and the i-STAT measurements was not significant

($p=0.07$) and the 95% confidence interval was not well fitted to the data. The linear regression model for the relationship between the lactate assay and the i-STAT measurements was significant ($p<0.05$) and the 95% confidence interval closely fitted to the regression line (Figure 31).

The Na^+ and K^+ values obtained in the lab could not be compared to i-STAT measurements as the i-STAT failed to give any values for Na^+ and K^+ during the initial blood testing. The laboratory values obtained for lactate, glucose, Na^+ and K^+ were not significant predictors for impaired reflexes or delayed mortality, however only 7 samples for each parameter were tested.

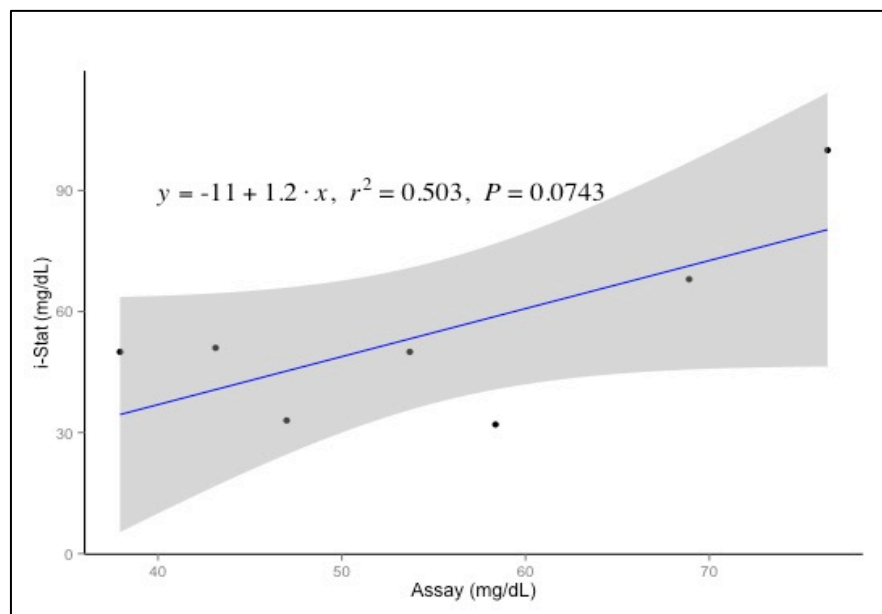

Figure 30. Linear regression model of glucose concentrations measured with assay and by i-STAT CG8+. Gray area around fitted line represents 95% confidence interval

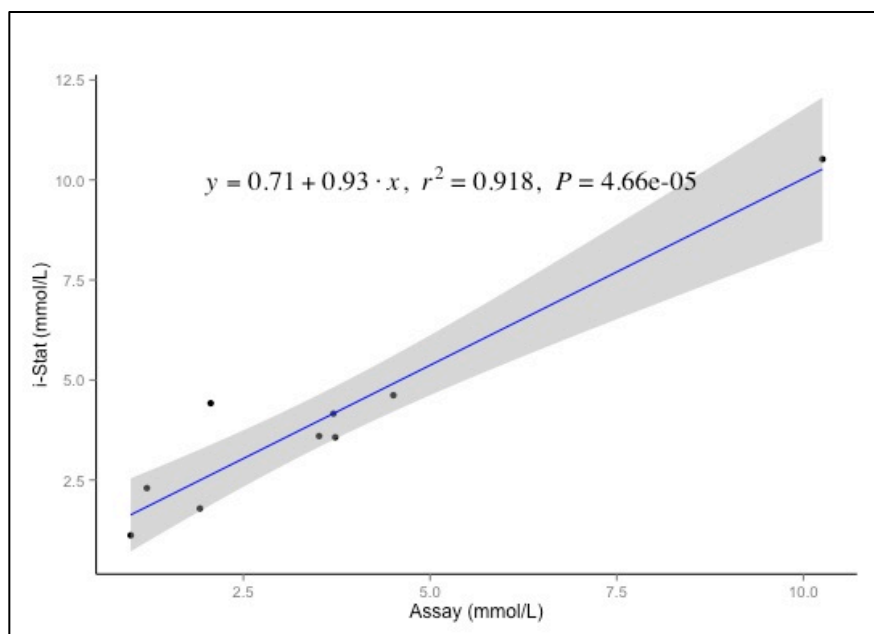

Figure 31. Linear regression model of lactate concentrations measured with assay and by i-STAT CG8+. Gray area around fitted line represents 95% confidence interval

Discussion

The most commonly impaired reflexes, equilibrium and tail grab, were also the two reflexes observed once the fish were placed back in the water. These reflexes play an important role in predator evasion and the ability of the fish to return to its natural position above the reef complex. The equilibrium response is perhaps the easiest to observe by recreational anglers as it is naturally witnessed when fish are returned to the water after de-hooking. In contrast to reflex impairments observed in other teleost species, the vestibular-ocular response and the head complex reflex were never impaired. Body flexion was the most often impaired reflex in rock sole while body flexion and the vestibular ocular reflex were most impaired in halibut species (Davis, 2007). This highlights the necessity of identifying appropriate reflexes in a particular species, in both unstressed and stressed fish, as different species may have vastly different patterns in

which reflexes become most frequently impaired in response to stress. The complex behaviors the reflexes make up will also become impaired in response to increasing stress and each species' unique morphology and behavior will dictate how stress affects the complex behaviors necessary for survival.

Impaired reflexes were significantly related to air exposure in both individual fish and when fish were averaged over groups. The point at which 50% of reflexes were impaired (9.72 minutes) was not observed in terms of the experiment, but rather represents a number obtained from the model. If this estimate holds true, and the model is extended into longer time scales of air exposure, then 10 minutes of air exposure is outside the reasonable length of time these fish could be exposed to air before being discarded. The LD50 for proportion of impaired reflexes was 0.26 and 0.35 for averages and individuals respectively. This corresponds to air exposures near 5 minutes. With experienced fisherman, this is most likely beyond the time fish would be out of the water. However, with inexperienced, recreational fishers this length of air exposure may be observed before the fish is discarded. Additionally, if the fish are gut hooked or with multiple hooks, the time to de-hook would most likely increase, potentially decreasing post-release survival rates (Rummer, 2007).

The lethal dose of proportion of impaired reflexes is relatively low in yellowtail (0.26) snapper as compared to other species in which reflex impairment was assessed. Halibut (*Hippoglossus stenolepis*) experienced 50% mortality near 0.8 of impaired reflexes, while rock sole (*Lepidopsetta polyxystra*) was approximately 0.4. The stressors used to assess impaired reflexes and mortality were slightly different for the two species, rock sole were towed prior to reflex assessment while halibut were towed and then

exposed to air before reflex assessments. The LD₅₀ in yellowtail snapper is quite similar to pollock (*Theragra chalcogramma*) (0.2) and salmon (*Oncorhynchus kisutch*) (0.1), which were only exposed to towing and not exposed to the air (Davis, 2007). Other studies utilizing impaired reflex methodology found that air exposure was the most significant predictor of delayed mortality; however, it was often used in combination of stressors, such as tow duration and air exposure as was the case with halibut (Humborstad *et al.*, 2009). The morphological and physiological variations of all species as well as the stressors present in each unique fishery will dictate how susceptible each species is to the stress of being caught. Furthermore, the use of impaired reflexes to predict delayed mortality in more sensitive species can be challenging due to high rates of mortality after comparatively small impairments in reflexes.

Differences between conditions in the controlled environment of this study and those present in the fishery are expected to impact the relationship between reflex impairment and delayed mortality. Additionally, the hatchery conditions under which the fish were held do not adequately mimic the natural environment fish are discarded into after being caught. Most likely, these differences will negatively impact reflex impairment and thus increase the likelihood of delayed mortality. Behaviors and reflexes necessary to avoid predation and return to a suitable habitat on the reef could potentially be greatly diminished resulting from the air exposure prior to discard. Loss of equilibrium upon return to the water has the potential to make discarded fish vulnerable to predation, as does the inability to burst swim away from a stimulus (Danylchuk *et al.*, 2007).

The stress response of teleosts, which the proportion of impaired reflexes indirectly assesses, aims to maintain acid-base balance within the fish. This is partially achieved through respiratory and metabolic pathways to decrease acidosis. The i-STAT measured components of both of these pathways: the respiratory pathway through the partial pressure of CO₂, an acid, and the metabolic pathway via measurement of pH and base excess (BE_{ef}) (Schwalme and Mackay, 1985; Wendelaar Bonga, 1997). The respiratory acidosis parameters measured by the i-STAT (CO₂) were not significant for either impaired reflexes or delayed mortality; however, metabolic acidosis parameters (pH and BE_{ef}) were significant.

Base excess measurements with the i-STAT are calculated from HCO₃ and pH levels. These calculations are based on 37°C and the amount of base needed to return plasma pH to 7.4, $BE_{ef} = HCO_3 - 24.8 + 16.2(pH - 7.4)$ (i-STAT Technical Bulletin, 2013). As fish are ectotherms, the temperature of the yellowtail blood in this study ranged from 24.5°C to 29°C, potentially introducing error in the above equation. In this study, base excess was positively correlated with and a significant predictor of delayed mortality. When levels of base excess significantly deviate from zero, it is assumed that the animal is struggling to return to homeostasis. It is surprising the i-Stat measurements of HCO₃ were not correlated with either impaired reflexes or delayed mortality as it would be expected that the yellowtail would retain bicarbonate with the help of the kidneys to compensate for the acid-base imbalance (Cameron, 1978). The i-Stat may not be able to detect the shifts in the levels of bicarbonate in teleosts as a result of the cartridges being

calibrated for mammalian blood, however the bias exists for all values measured by the i-Stat. It is also possible, for future studies, to re-examine the conversion equation supplied by Abbot and derive new constants.

The measured levels of base excess in yellowtail snapper were negative, indicating a base deficit in the blood and a metabolic acidosis. Increasing proportions of impaired reflexes were significantly related to decreasing pH values, so as impaired reflexes increased in response to stress, the blood became more acidic. It is reasonable then, that base excess was negative, indicating an excess of acid in the blood.

Delayed mortality was also significantly predicted though increased concentration of lactate, a secondary response to acute stress in teleosts (Barton, 2002; Schwalme and Mackay, 1985; Wendelaar Bonga, 1997). Lactate is often elevated in response to handling or capture stresses; however, it is not often a good predictor of mortality (Skomal, 2007). Cortisol and lactate concentrations were assessed in stressed sablefish and no correlation was found between elevated levels of these stress parameters and mortality (Davis, 2001).

A build-up of lactate occurs when the animal receives too little, or in the case of this study, no oxygen from the air exposure, resulting in impaired cellular respiration. This in turn forces cell to metabolize glucose anaerobically, resulting in the formation of lactate (Butler *et al.*, 1979; Hobbs *et al.*, 2010; Holeyton and Randall, 1967). Impaired cellular respiration leads to a decrease in pH values, which was observed to be significant for predicting impaired reflexes, and paired with the increase of lactate, signifies lactic

acidosis (Hobbs *et al.*, 2010). The reduction of cellular O₂ reduces the amount of ATP available to the muscles of the fish (Wu, 2002), which could be the mechanism causing the impairment of reflexes observed in this study.

The i-STAT and other portable point of care devices have begun to gain more attention for use in field and fishery settings. However, these devices were originally intended for use in a clinical setting. The measurements and calculations of blood parameters are based on algorithms written for human blood. Teleost red blood cells are nucleated, unlike human red blood cells, which can cause some teleost species to have strong Bohr/Haldane and/or Root effects. These can introduce bias in the measurements of blood gases as well as acid-base interactions (Harter *et al.*, 2014). The Root effect can limit the amount of oxygen bound to the hemoglobin and in turn can effect acid-base regulation. The blood gases in this study were not significant for predicting delayed mortality or reflex impairment, however base excess and pH were both significant factors in survival and reflex impairment respectively. While the actual values measured have the potential to be influenced by the differences in fish red blood cells and may not be accurate, this study focused on the concentrations of these parameters in relation to larger, whole animal responses to stress. The absolute value of pH and base excess were not necessary to predict survival. However, future studies should aim to validate pH measurements obtained through i-STAT measurements.

Yellowtail snapper are a relatively long-lived species, with a reported maximum age of 17 years; however, most fish caught in the southeastern US are estimated to be between 1 and 9 years of age (Muller *et al.*, 2003). Based on the von Bertalanffy growth equation (E. R. Garcia *et al.*, 2003), fish between 20 to 30 cm fork length are between 1.5

and 3 years of age. Previous studies with sablefish found younger fish were more likely to succumb to stressors immediately than were older fish, which were instead more likely to exhibit delayed mortality (Davis, 2007). This study did not specifically compare response to stressors in different ages of fish, particularly as older fish would be retained and not discarded. However, there is the potential for younger fish to be more vulnerable to the stressors of discarding than older fish in the fishery.

Conclusions

This study demonstrated that length of air exposure is a significant predictor for impaired reflexes in yellowtail snapper. With fish that were not blood sampled, impaired reflexes were a significant predictor for delayed mortality. With blood-sampled fish, pH was a better predictor for the proportion of impaired reflexes than air exposure. In addition, lactate and base excess concentrations predicted delayed mortality better than impaired reflexes. In the absence of blood physiology parameters, the use of impaired reflexes is a good method to assess the rates of the post-release survival in field conditions. Furthermore, the i-STAT provided reliable and valid measurements of glucose and lactate concentrations as compared to traditional laboratory assays.

Chapter 5: Ecopath model examining the effects of the tuna purse-seine fishery on the ecosystem of the Gulf of Guinea

Overview

Fisheries impact both the species that are being targeted as well as the surrounding ecosystem through modifications in community structure, diversity, changes in trophic interactions and bycatch species mortality (Amandè et al., 2010; Cox et al., 2002; Pauly et al., 2002). These changes can be difficult to quantify as historically attention has been focused on the dynamics of single species or stocks and for areas that are particularly important for management. Ecosystem models, however, seek to broaden the focus away from single stock dynamics. Ecopath is currently the most extensively employed ecosystem modeling software available (Christensen and Walters, 2004a; Plagányi, 2007; Araujo et al, 2008). It allows for the trophic flows between discrete trophic levels, or functional groups, to be described and quantified (Polovina, 1984; Walters et al, 1997; Pauly et al, 2000) and combines the theory of classical ecology, food chains and linkages, to the concept of mass balance and energy conservation (Ulanowicz, 1980; Christensen and Walters, 2004). Ecopath with Ecosim (EwE) models can provide a framework to assess the status of ecosystems and identify changes in recent decades due to fishing pressure.

Tuna fisheries operate in the open ocean, away from most coastal fishing fleets and land-based influences. Modeling open-ocean ecosystems is challenging due to the underlying closed system assumption of many ecosystem models. Several Ecopath models, however, have been developed for pelagic systems, including a tropical eastern

Pacific Ocean model (ETP) developed by the Inter-American Tropical Tuna Commission (IATTC) and models of the western and central Pacific (CNP) (Cox *et al.*, 2002b; Griffiths, 2013; Olson and Watters, 2003).

This Ecopath model was developed using a previously published Ecopath model for a smaller region of the Gulf of Guinea, termed the PICOLO model (Schultz and Menard, 2003; Schultz, 2001), and enlarged and updated for this paper's purposes. Using European Union observer data, ICCAT catch and effort databases as well as published scientific literature, a model of the northern Gulf of Guinea was developed.

Methods

Ecopath Approach

Ecopath allows for trophic flows between species or groups of species, termed functional groups, to be quantified in a steady state model (Christensen and Walters, 2004). It is run from a series of linear equations balancing the net production of each functional group to all sources of mortality, migration or change:

$$P_i = \sum_j B_j \cdot M_{2ij} + Y_i + E_i + BA_i + P_i \cdot (1 - EE_i)$$

Eq. 10

where the production (P) of the i th component, or functional group, of the ecosystem is divided into predation mortality (M_{2ij}) caused by the biomass of the other predators (B_j); exports from the system both from fishing catches (Y_i) and emigration (E_i); biomass accumulation in the ecosystem (BA_i); and other mortality or mortality not captured by the

model ($1-EE_i$). EE_i is the ecotrophic efficiency of the group within the system, or the proportion of the production P_i that is exported out of the ecosystem (i.e., by fishing activity) or consumed by predators within it. Equation (1) can be re-expressed as:

$$B \cdot (P/B)_i = \sum_j B_j \cdot (Q/B)_j \cdot DC_{ij} + Y_i + E_i + BA_j + B_j \cdot (P/B)_i \cdot (1 - EE_i)$$

Eq. 11

where $(P/B)_i$ indicates the production of functional group i per unit of biomass and is equivalent to total mortality, or Z , under steady-state conditions (Allen, 1971); $(Q/B)_i$ is the consumption of i per unit of biomass; and DC_{ij} indicates the proportion of i that is in the diet of predator j in terms of volume or weight units. EwE parameterizes the model by describing a system of linear equations for all the functional groups in the model, where for each equation at least three of the basic parameters: B_i , $(P/B)_i$, $(Q/B)_i$ or EE_i have to be known for each group i , in addition to the diet composition. The energy balance within each group is ensured when the sum of consumption by group i equals the sum of production by i , respiration by i and food that is unassimilated by i (Forrester *et al.*, 2012).

Model Structure and Parameterization

The model area is 3,837,000 km² and encompasses the region from 12°N to 5°S and from 20°W to 10°E, following the shelf break herein called the Gulf of Guinea model (Figure 32). The model represents the average condition of the ecosystem from 2003-2013 as defined by the estimates of stock size and harvest during this period. The main focus of the model is to represent the major components of the catch and bycatch families or functional groups that are observed in the offshore tuna fishery; Scombridae,

Carangidae, Balistidae, and Coryphaenidae. The Scombridae functional group includes members of the Scombridae group that are not specifically targeted by the tuna purse seine fleets.

The Gulf of Guinea region has been poorly studied relative to other large ocean regions and thus there is little region-specific information for some of the functional groups. Data available on abundance and occurrence of species in the region were used, as were bycatch amounts recorded by the tuna purse seine fishery. In cases where species were reported in the area but no detailed information was available to develop the necessary parameters to run Ecopath, parameter values from the PICOLO model or s from previously published models of tropical pelagic systems were used.

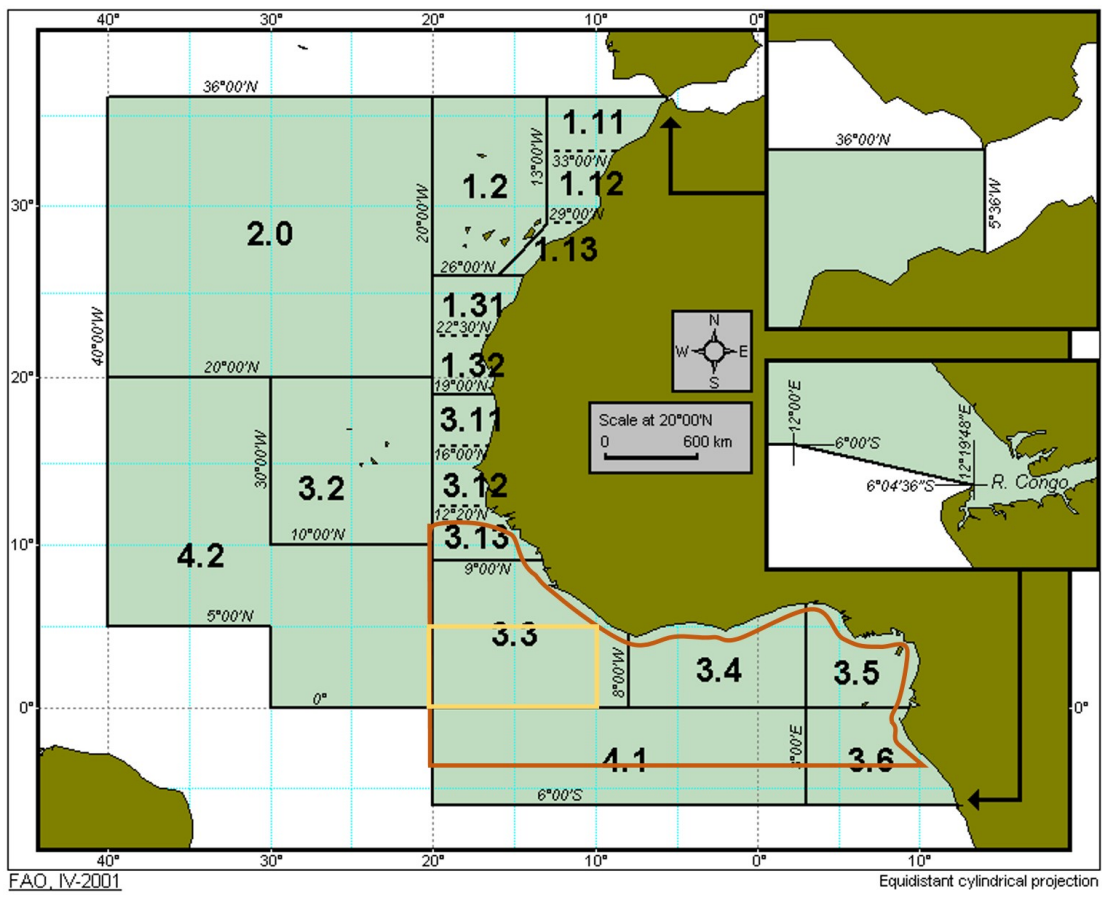

Figure 32. Modified map of FAO fishing areas with PICOLO model area outlined in yellow and the Gulf of Guinea model area outlined in brown.

Functional Groups

Functional group designations were developed from the European Union observer database spanning 2003-2013, the original PICOLO model and other published reports from the region (Table 23). Groups that comprised more than a single species were classified according to family or similar diet composition and ecosystem role, (e.g. small mesopelagic fish).

Unless otherwise stated specifically, biomass estimates were obtained through the observer database model using the ratio estimator method and estimated exploitation rates:

$$B_i = \frac{1}{E_{i,j}} \sum_j \left(\frac{Y_{i,j}^{obs}}{Y_{T,j}^{obs}} Y_{T,j} \right)$$

Equation 12

where $Y_{i,j}^{obs}$ represents the total bycatch for each functional group i by fishing mode j during the observed trips and $Y_{T,j}^{obs}$ is the total tuna catch associated with the observed bycatch during fishing mode j (Schultz and Menard, 2003). The total tuna catch $Y_{T,j}$ was used as the auxiliary variable in ratio estimator method to obtain the total bycatch for the purse-seine fishery in the eastern Atlantic (Stratoudakis *et al.*, 1999). The total tuna catch was found using ICCAT's Task II database for tropical tunas. The average bycatch and catch from 2003-2013 were used for the ratio estimators. The exploitation rate E was calculated from estimates of natural mortality and fishing mortality of each functional

group as $E=F/Z$. The groups caught as bycatch are not formally assessed and therefore, fishing mortality is unknown. Fishing mortality was calculated using the default approximation method for data poor fisheries of $F=0.8M$ (Gabriel and Mace, 1999), where M was either taken from the literature or inferred from life history parameters (see below).

Seabirds

Migratory seabirds and breeding colonies on islands in the Gulf of Guinea were included in the seabird functional group. Seabird species present in the Gulf of Guinea were identified through the British Ornithologists Union checklist for the birds of the Gulf of Guinea (Jones and Tye, 2006). Birds classified as offshore species or as migrants to the area were also included in the functional group. The 12 species included belong to four families: Procellidae (petrels and shearwaters), Hydrobatidae (storm petrels), Sulidae (boobies), and Sternidae (terns).

Biomass estimates for *Sula leucogaster*, *Sterna fuscata*, *Anous stolidus*, and *A. minutus* were taken from a survey conducted by Birdlife International on the breeding colonies found on 2 islands of São Tomé e Príncipe (Valle *et al.*, n.d.). The survey was conducted in February 2013 and counted breeding pairs of species. For the biomass estimates, it was assumed that these species remained in the ecosystem for the entire year.

Table 23. Species composition of functional groups with more than one species.

Functional Group	Species	Functional Group	Species		
Seabirds	<i>Sterna fuscata</i>	Carangidae	<i>Caranx crysos</i>		
	<i>Anous stolidus</i>		<i>Elagatis bipinnulata</i>		
	<i>Anous minutus</i>		<i>Naucrates ductor</i>		
	<i>Sula dacylatra</i>		<i>Seriola rivoliana</i>		
	<i>Sula leucogaster</i>		<i>Uraspis secunda</i>		
	<i>Calonectris diomedea</i>	Coryphaena	<i>Coryphaena equiselis</i>		
	<i>Oceanites oceanicus</i>		<i>Coryphaena hippurus</i>		
	<i>Fregetta tropica</i>	Balistidae	<i>Balistes capricus</i>		
	<i>Hydrobates pelagicus</i>		<i>Balistes punctatus</i>		
	<i>Oceanodrama castro</i>		<i>Canthidermis maculata</i>		
<i>Oceanodrama leucorhoa</i>	Scombridae	<i>Acanthocybium solandri</i>			
<i>Puffinus gravis</i>		<i>Auxis thazard/rochei</i>			
		<i>Euthynnus alletteratus</i>			
Sharks	<i>Alopias vulpinus</i>		<i>Lobotes surinamensis</i>		
	<i>Galeocerdo cuvier</i>	Epipelagic I	<i>Ruvettus pretiosus</i>		
	<i>Carcharhinus limbatus</i>		<i>Sphyrna barracuda</i>		
	<i>Carcharodon carcharias</i>				
	<i>Isurus oxyrinchus</i>	Epipelagic II	Tetraodontidae		
	<i>Carcharhinidae spp</i>		<i>Aluterus monoceros</i>		
	<i>Carcharhinus falciformis</i>		<i>Kyphosus sectatrix</i>		
	<i>Carcharhinus longimanus</i>		<i>Remora remora</i>		
	<i>Prionace glauca</i>		Family		
	<i>Sphyrna lewini</i>		Myctophidae		
	<i>Sphyrna mokarran</i>	Sternoptychidae			
	<i>Sphyrna zygaena</i>	Stomiidae			
	<i>Rhincodon typus</i>	Small mesopelagics	Gempylidae		
	Gonostomidae				
	Photichthyidae				
	Argentidae				
	Melanostomidae				
	Opisthroproctidae				
Sea turtles	<i>Chelonia mydas</i>	Small epipelagics	<i>Cheilopogon cyanopterus</i>		
	<i>Dermochelys coriacea</i>		<i>Cheilopogon melanurus</i>		
	<i>Lepidochelys kempii</i>		<i>Cheilopogon milleri</i>		
	<i>Lepidochelys olivacea</i>		<i>Cheilopogon nigricans</i>		
			<i>Cheilopogon pinnatibarbatus</i>		
Ray	<i>Dasyatis violacea</i>	Macrozooplankton	Crustaceans		
	<i>Manta birostris</i>		Fish larvae		
	<i>Mobula mobular</i>		Small molluscs		
Billfish	<i>Istiophorus albicans</i>		Meso zooplankton	Copepods	
	<i>Makaira indica</i>			Microzooplankton	Copepod larvae
	<i>Makaira nigricans</i>				Foraminifera
	<i>Tetrapturus albidus</i>				Radiolarians
	<i>Tetrapturus angustirostris</i>				Tintinnèdes
	<i>Tetrapturus pfluegeri</i>				Pteropods
<i>Xiphias gladius</i>					
Marine mammals	<i>Balaenoptera borealis</i>				
	<i>Balaenoptera edeni</i>				
	<i>Balaenoptera physalus</i>				
	<i>Megaptera novaeangliae</i>				
	<i>Delphinus delphis</i>				
	<i>Globicephala macrorhynchus</i>				
	<i>Grampus griseus</i>				
	<i>Kogia simus</i>				
	<i>Lagenodelphis hosei</i>				
	<i>Orcinus orca</i>				
	<i>Peponocephala electra</i>				
	<i>Physeter macrocephalus</i>				
	<i>Pseudorca crassidens</i>				
	<i>Stenella attenuata</i>				
	<i>Stenella chymene</i>				
	<i>Stenella frontalis</i>				
	<i>Stenella longirostris</i>				
	<i>Steno bredanensis</i>				
	<i>Tursiops truncatus</i>				

For the remaining seabird species, biomass estimates were obtained from the Ecopath model of the central Atlantic developed by Vasconcellos and Watson (2004). It was assumed that Procellidae species remained in the region for half of the year as the Hydrobatidae species, it was assumed they remained in the system for one season, as these species inhabit the southern or northern hemispheres depending on their specific range. Weighting factors were calculated from the proportional biomass amounts for each species and these were used to adjust Q/B and P/B values for the functional group. Two species from the Procellidae family, the Greater shearwater (*Puffinus gravis*) and Cory's shearwater (*Calonectris diomedea*), were the most abundant in terms of biomass (t/km²).

Table 24. Values used to calculate P/B and Q/B for the seabird functional group.

Species	Biomass (mt)	Weight (g)	Survival (%)	PB (yr)	Daily Ration (g)	Q/B (yr)
<i>Anous minutus</i>	0.98	122.50	87	0.13	0.22	79.02
<i>Anous stolidus</i>	4.22	211.00	87	0.13	0.22	79.02
<i>Calonectris diomedea</i>	836.01	810.00	93	0.07	0.19	69.29
<i>Fregatta tropica</i>	0.42	40.00	90	0.10	0.28	103.38
<i>Hydrobates pelagicus</i>	12.16	25.00	90	0.10	0.31	111.62
<i>Oceanites oceanicus</i>	265.52	40.00	90	0.10	0.28	103.38
<i>Oceanodrama castro</i>	0.29	46.50	90	0.10	0.28	103.38
<i>O. leucorhoa</i>	5.66	46.50	90	0.10	0.28	103.38
<i>Puffinus gravis</i>	8,325.00	832.50	93	0.07	0.20	72.15
<i>Sterna fuscata</i>	39.93	180.00	87	0.13	0.22	79.02
<i>Sula dacylatra</i>	10.00	1786.00	93	0.07	0.16	58.60
<i>Sula leucogaster</i>	3.90	1300.00	93	0.07	0.16	58.60

P/B was found using adult annual survival rates from values obtained in the Central Atlantic model (Vasconcellos and Watson, 2004). Q/B ratios were calculated from diet studies and values obtained through diet studies (Nilsson and Nilsson, 1976; Vasconcellos and Watson, 2004) from the following equation:

$$\log_{10}R = -0.293 + 0.85 \cdot \log_{10}W$$

Eq. 13

R represents food consumption in grams per day and W is the body weight of the bird in grams. For the purposes of this model, average body weights of each species were used and the daily ration was scaled up to a year. Survival rates were obtained from Vasconcellos and Watson and used to calculate the total mortality for each species. As P/B can be taken as an estimate of total mortality, published survival rates were used to calculate P/B (Table 24). Diet information was obtained for the four major family groups through several studies from the literature (Prince and Morgan, 1987; Croxall and Prince 1996; Barrett et al. 2007). Cephalopods are very common prey items across seabird species, followed by crustaceans and small fish species. The Procellidae family, which includes the 2 major species within this functional group, have a great diversity of prey in terms of species consumed, however the majority of their diet is made up of omnastrephid squids, included in the Cephalopod functional group (Croxall and Prince, 1996).

Sharks

Shark species present in the model were identified through the entries in the observer database and species that were present in the original PICOLO model. While there are several species within the functional group (Table 23), the majority of the discarded individuals were silky sharks (*Carcharhinus falciformis*), followed by several species of hammerhead (*Sphyrna spp.*). As a result, this functional group's parameters are largely based on silky shark and hammerhead P/B and Q/B values.

Shark biomass was calculated using equation 3 and the observer database. P/B was estimated using total instantaneous mortality (Z). Total instantaneous mortality is calculated from the sum of natural mortality and fishing mortality.

$$P/B \approx Z = F + M$$

Equation 14

M was estimated from the von Bertalanffy growth parameters using the natural mortality equation developed by Jensen (1996):

$$M = 1.60K$$

Equation 15

where K is the curvature parameter from the von Bertalanffy equation. This is equation was used as opposed to the commonly used equation developed by Pauly (1980) as that equation was derived from over 175 species of fish, only 2 of which were elasmobranch species. Since the majority of the shark species contained within the functional group have not been formally assessed, F was estimated at $F=0.8M$ (Branstetter 1987, Piercy et al. 2010, Griffiths 2013).

Table 25. Life history parameters, weighting factors (WF) and source for each species of sharks in functional group Sharks.

Specie	M yr ⁻¹	F yr ⁻¹	Z yr ⁻¹	L _∞ cm	K yr ⁻¹	Weight. factor	Source
<i>Alopias vulpinus</i>	0.17	0.14	0.31	651	0.11	0.22%	Cailliet et al. 1983
<i>Galeocerdo cuvier</i>	0.32	0.26	0.58	301	0.20	0.00%	Wintner & Dudley 2000
<i>Carcharhinus limbatus</i>	0.44	0.35	0.79	176	0.27	0.00%	Branstetter 1987b
<i>Carcharodon carcharias</i>	0.10	0.08	0.19	544	0.07	0.00%	Wintner and Cliff 1999
<i>Isurus oxyrinchus</i>	0.12	0.09	0.21	321	0.07	1.81%	Cailliet et al, 1983
<i>Carcharhinus falciformis</i>	0.24	0.20	0.44	291	0.15	83.40%	Branstetter 1987a
<i>C. longimanus</i>	0.12	0.10	0.22	325	0.08	4.17%	Lessa et al. 1999
<i>Prionace glauca</i>	0.36	0.29	0.64	266	0.22	0.67%	Cailliet et al, 1983
<i>Sphyrna lewini</i>	0.12	0.09	0.21	329	0.07	5.05%	Branstetter, 1987b
<i>S. mokarran</i>	0.26	0.20	0.46	264	0.16	1.92%	Piercy et al. 2010
<i>S. zygaena</i>	0.10	0.08	0.17	278	0.06	2.76%	Coehlo et al, 2011

Q/B was estimated through von Bertalanffy parameters and the empirical equation developed by (Palomares and Pauly, 1989):

$$\log Q/B = 7.964 - 0.204 \log W_{\infty} - 1.965T + 0.083A + 0.532h + 0.398d$$

Eq. 16

Where T is the mean temperature, A is the aspect ratio of the caudal fin, h and d are dummy variables corresponding to food type the animal consumes. For detritivores and carnivores, h equals 0 and 1 for herbivores. D is valued at 1 for detritivores and 0 for herbivores and carnivores. The above equation uses weight at infinity (W_{∞}) which was calculated from length at infinity (L_{∞}) using the appropriate length conversion factors and the equation below:

$$W = aL^b$$

Eq. 17

Total amounts of each species reported in the bycatch were used to develop weighting factors which were used to determine the overall P/B and Q/B values for the functional group (Table 25).

Diets of sharks include a wide variety of species, which tend to be area specific. In the case of silky sharks, stomach content studies have determined squid, crab and small epipelagic species make up large parts of their diets. The diet matrix was estimated through studies in similar ecosystems and previously published models (Cabrera-Chávez-Costa *et al.*, 2010; Griffiths, 2013).

Marine mammals

There is a lack of information on the cetacean species found within the region (Bamy *et al.*, 2010; Weir, 2011). A survey of the documented species shows support for a resident population of cetaceans in the tropical waters of the eastern Atlantic. The exception to this are humpback whales, *Megaptera novaeangliae*, which use the region exclusively as a breeding and calving ground (Bamy *et al.*, 2010; Weir, 2011). The 19 species contained in the marine mammal functional group were determined from a list of marine mammal sightings in the Gulf of Guinea (Weir, 2010; Weir, 2011). These include both baleen whales and toothed whales. Twenty-eight species have been documented within the Gulf of Guinea, however, many of the sightings or occurrences are from whaling records or strandings; this information does not allow for information on abundance or range at sea.

Species biomass estimates were calculated from a previous Ecopath model of the central Atlantic (Vasconcellos and Watson, 2004). The biomass estimates are quite tentative, as the marine mammals in the Gulf of Guinea have been poorly described. It

was assumed all marine mammals, with the exception of *M. novaeangliae*, remained in the region of the model for a full year. Values of Q/B were obtained from a model of the Central Atlantic and weighted to account for the proportional biomass of each species (Vasconcellos and Watson, 2004). P/B was estimated from a study conducted on marine mammals in the Pacific Ocean and was assigned a value of 0.2 (Trites *et al.*, 1997).

Table 26. Biomass, weighting factor (WF) and calculated Q/B values (Vasconcellos and Watson 2004) for species of marine mammals in the Marine Mammal functional group.

Species	Biomass (t)	Weighting Factor	Q/B yr ⁻¹
<i>Balaenoptera borealis</i>	54.81	3%	5.21
<i>Balaenoptera edeni</i>	72.69	4%	5.26
<i>Balaenoptera physalus</i>	844.77	45%	4.10
<i>Megaptera novaeangliae</i>	94.46	5%	4.63
<i>Delphinus delphis</i>	6.53	0%	15.16
<i>Globicephala macrorhynchus</i>	9.95	1%	9.95
<i>Grampus griseus</i>	7.26	0%	12.37
<i>Kogia simus</i>	0.06	0%	14.51
<i>Lagenodelphis hosei</i>	0.72	0%	14.67
<i>Orcinus orca</i>	9.55	1%	7.76
<i>Peponocephala electra</i>	0.19	0%	14.40
<i>Physeter macrocephalus</i>	749.13	40%	5.03
<i>Pseudorca crassidens</i>	3.14	0%	10.20
<i>Stenella attenuata</i>	4.42	0%	15.81
<i>Stenella clymene</i>	0.11	0%	16.91
<i>Stenella frontalis</i>	0.16	0%	15.77
<i>Stenella longirostris</i>	1.94	0%	17.34
<i>Steno bredanensis</i>	0.59	0%	14.77
<i>Tursiops truncatus</i>	4.01	0%	12.81

The diet composition of humpback whales and sperm whales, *Physeter macrocephalus*, the largest component of the marine mammal functional group in terms of biomass, was estimated from a large review of published diet studies. For humpback whales, the majority, 55%, of their diet comes from large zooplankton, followed by small epipelagic fish. Sperm whale diets were comprised of large squids, followed by small squids and small epipelagic fish (Pauly *et al.*, 1998).

Rays

The ray functional group is comprised of two families, Mobulidae, which include devil-rays (*Mobula* spp.) and manta rays (*Manta* spp.), and Dasyatidae, pelagic stingrays. The functional group is dominated by the biomass of devil-rays (*Mobula japonica*) with manta and pelagic stingrays making up a smaller proportion (5% and 0.23% respectively). Therefore, parameter estimates were taken solely for *Mobula* species, *Mobula japonica* (spinetail mobula) and *Mobula mobular* (devil fish). Initial biomass estimates were obtained through the observer database using equation 3. There is little published information on growth studies of mobulids but they are assumed to be slow growing and long-lived, similar to other elasmobranch species (Couturier *et al.*, 2012). The lack of published information on growth and diet studies necessitated the use of P/B and Q/B estimates from a previously published Ecopath model of the eastern and central Pacific (Olson and Watters, 2003). The initial P/B was estimated to be 0.25 year⁻¹ and the initial Q/B value was 3.9 year⁻¹. The natural mortality of manta and devil rays seems to be low and the major predation pressure comes from sharks. Diet composition was estimated from previously published studies of stomach content analysis (Couturier *et al.*, 2012; Notarbartolo-di-Sciara, 1987). Mobulids feed primarily on zooplankton and small fish and form seasonal feeding aggregations, which does affect the amount and time of year they are caught in tuna purse seine fisheries (Torres-Irineo *et al.*, 2014).

Sea turtles

The islands within the Gulf of Guinea, Principe and São Tomé, Annobón and Bioko, are important nesting grounds for the leatherback, Olive ridley, green and hawksbill turtles. These nesting populations have been severely depleted on these islands

due to overexploitation of the species from the meat and egg trades (Castroviejo *et al.*, 1994a). Biomass was estimated from the observer database using equation 3 as well from studies on nesting beaches (Castroviejo *et al.*, 1994a). This functional group is comprised of species present in the observer bycatch database: Green turtles (*Chelonia mydas*), Hawksbills (*Eretmochelys imbricate*), Leatherback (*Dermochelys coriacea*), Kemp's ridley (*Lepidochelys kempii*), and Olive ridley (*Lepidochelys oliveacea*). The principal species within the database are leatherback (56%) and Olive ridley (23%). The P/B and Q/B parameters were obtained through a previously published models (Olson and Watters 2003; Griffiths 2013). P/B was estimated from the natural mortality of 0.190 year⁻¹ as it was assumed there should not be no targeted fishing pressure on sea turtles resulting from the commercial fisheries within the model. From the observer database, all turtles caught were discarded alive and it was assumed there was no delayed mortality. The initial Q/B estimate of 3.5 year⁻¹ was obtained through a previous Ecopath models in the western Pacific (Griffiths, 2013) and a Caribbean reef (Opitz, 1996). The diet of leatherback turtles is made up mainly of gelatinous zooplankton while olive ridleys feed on zooplankton crustaceans and small fish (Polovina *et al.* 2004; Hays *et al.* 2014).

Billfish

Billfish biomass was calculated from available stock assessments conducted by ICCAT as well as calculations from information on population declines (Anonymous, 2014a; Collette *et al.*, 2011). P/B and Q/B values were obtained from published life history values used in ICCAT assessments and equations 5 and 7 (Anonymous, 2013, 2011a, 2010a).

Table 27. Input parameters and final calculations for the Billfish functional group.

Species	Weighting factor	M yr ⁻¹	F yr ⁻¹	Linf cm	K yr ⁻¹	P/B yr ⁻¹	Q/B yr ⁻¹
<i>Istiophorus albicans</i>	23%	0.33	0.50	183	0.16	0.83	9.7
<i>Makaira indica</i>	6%	0.56	4.00	317.9	0.47	4.56	8.3
<i>Makaira nigricans</i>	1%	0.42	4.00	395.7	0.33	4.42	6.5
<i>Tetrapturus albidus</i>	1%	0.66	4.00	303.9	0.58	4.66	8.5
<i>Xiphias gladius</i>	69%	0.24	0.18	264	0.12	0.42	4.7

The diet matrix was developed from studies of stomach content analysis (Hernández-García, 1995; M Potier *et al.*, 2007). The largest components of the diet are fish and cephalopods. Studies from the Indian Ocean found that yellowfin tuna and swordfish have high levels of diet overlap (M Potier *et al.*, 2007).

Skipjack

Skipjack biomass was estimated from the most recent stock assessment from ICCAT (Anonymous, 2014b). P/B was estimated using the total instantaneous mortality, reflecting the recent ICCAT stock assessment estimation of fishing mortality at 0.4 and natural mortality of 0.8 (ICCAT, 2015). Q/B was estimated through von Bertalanffy parameters and empirical equations (eq. 5 and 7) (Palomares and Pauly, 1989). The diet composition was estimated from stomach content analysis conducted in the South Sherbro Area (Menard *et al.*, 2000) which showed the majority of skipjack diet is comprised of *Vinciguerria nimbaria* (Small Epipelagic functional group) as well as cephalopods. Other diet studies had the presence of small scombrid species in the stomachs of skipjack (Dragovich, 1966).

Yellowfin tuna

The yellowfin tuna (*Thunnus albacares*) functional group was split into a multi-stanza group to reflect differences in diet composition and the different size classes that are caught by various fisheries. Maturity is assumed to be knife-edge at 3 yrs, around 100 cm. The multi-stanza routine within Ecopath requires biomass, Q/B and Z estimations for the leading stanza, which was adult tuna in this case (Figure 33). The routine also requires

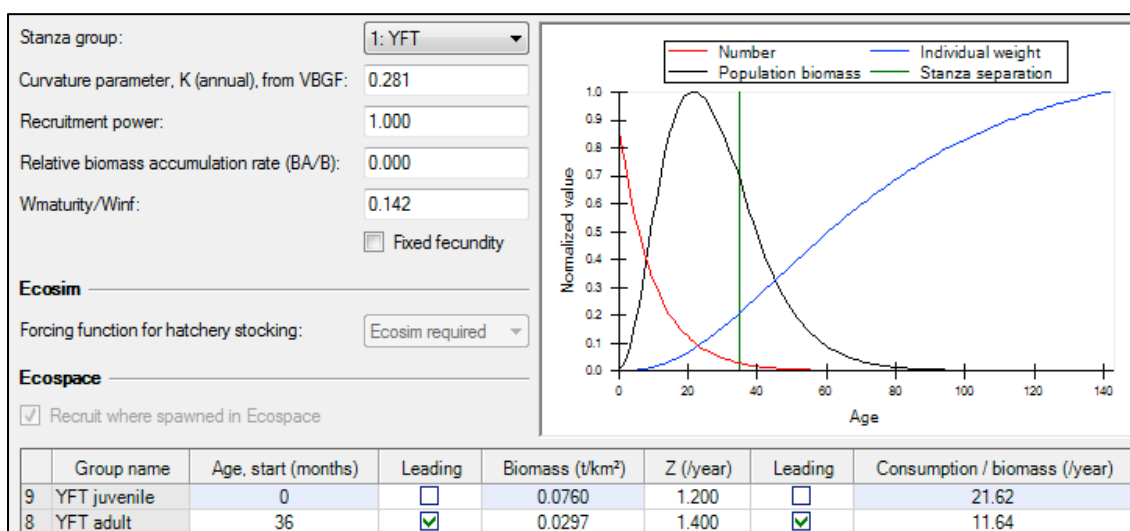

Figure 33. Multi-stanza routine within Ecopath to estimate parameters of non-leading stanza (juvenile yellowfin).

the Von Bertalanffy curvature parameter (K), the ratio of weight at maturity to weight at infinity. The K value used was 0.281 taken from a recent age and growth study of yellowfin in the Atlantic (Shuford *et al.*, 2007). The weight ratio was obtained through weight and growth parameters from the recent stock assessment, as were Z estimates (Table 28). Biomass estimates for adult yellowfin were obtained from the most recent stock assessment and the multi-stanza routine estimated juvenile biomass from the life history parameters (Anonymous, 2011b) Relative frequencies of size classes were

calculated using ICCAT catch-at-size data, and this information was used to calculate landings of juvenile and adult yellowfin (Figure 34). Q/B estimates for adult yellowfin were obtained through life history parameters from the most recent stock assessment for yellowfin and applied to equation 7, the juvenile Q/B estimate was obtained from the multi-stanza routine.

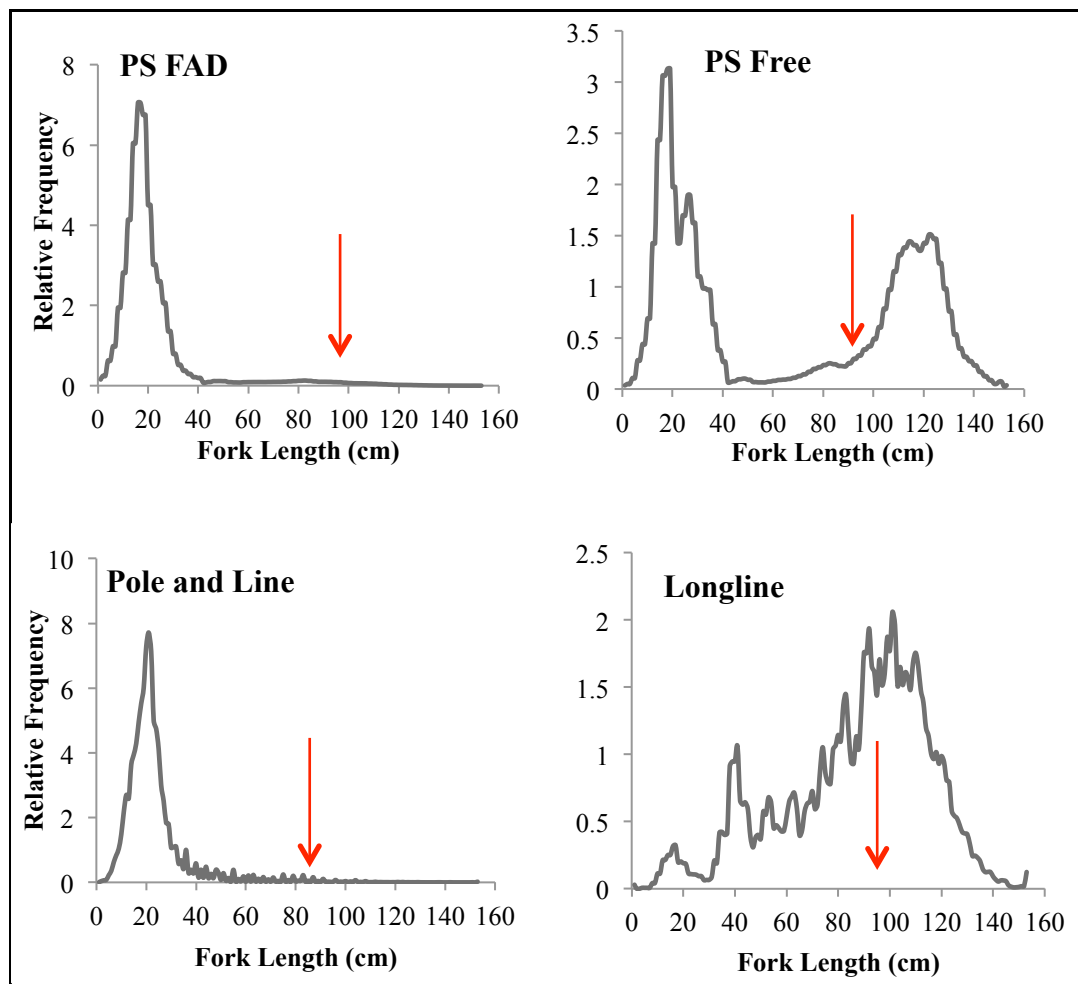

Figure 34. Size composition of catch of yellowfin tuna by gear group. Red arrow represents size at maturity.

Stomach content analysis done onboard a purse seine vessel targeting monospecific schools of large yellowfin in the Gulf of Guinea found that YFT were feeding exclusively on *Cubiceps spp.* (Bard *et al.*, 2002). In contrast, a study by Menard (2000) identified *Vinciguerria nimbaria* (small epipelagic) as the main prey item. Yellowfin undergo a strong ontogenetic shift in diet as seen in a diet study in Hawaii, where smaller size class tuna feed mainly on small planktonic species and larger tuna feeding mainly on teleost (Graham *et al.*, 2006). Prey items were also found using previously published Ecopath models (Cox *et al.*, 2002a). The diet also reflects the highly migratory nature of this species, with 40% of the diet coming from outside the model system.

Table 28. Natural mortality (M) and fishing mortality (F) used for initial instantaneous mortality (Z) and P/B for the tuna functional groups.

	Juvenile		Adult	
	M (yr ⁻¹)	F (yr ⁻¹)	M (yr ⁻¹)	F (yr ⁻¹)
Skipjack tuna			0.8	0.68
Yellowfin tuna	0.8	1	0.6	1.1
Bigeye tuna	0.8	0.25	0.4	0.32
Albacore tuna			0.4	0.4

Bigeye tuna

The bigeye tuna (*Thunnus obesus*) biomass amounts were calculated from a recent ICCAT stock assessment (Anonymous, 2011c). Like yellowfin, bigeye tuna were split into a multi-stanza group to reflect differences in diet composition and the different size classes that are caught by various fisheries (Figure 35 and Figure 36). Fishing mortality is higher on the lower age classes .25 and 0.32 on mature tuna. Length and weight parameters were used to calculate multi-stanza parameters (Zhu *et al.*, 2009). P/B

estimates for both juvenile and adult bigeye tuna were obtained through the most recent bigeye assessment and Q/B was estimated through the empirical equation developed by Palomares and Pauly (1998).

The diet composition was estimated through stomach content analysis done onboard purse seine vessels in the South Sherbro Area (Menard *et al.*, 2000). Like smaller sized yellowfin tuna, the major component of the smaller bigeye tuna was *V. nimbaria* (Ménard *et al.*, 2000). The diet also reflects the highly migratory nature of this species, with 40% of the diet coming from outside the model system.

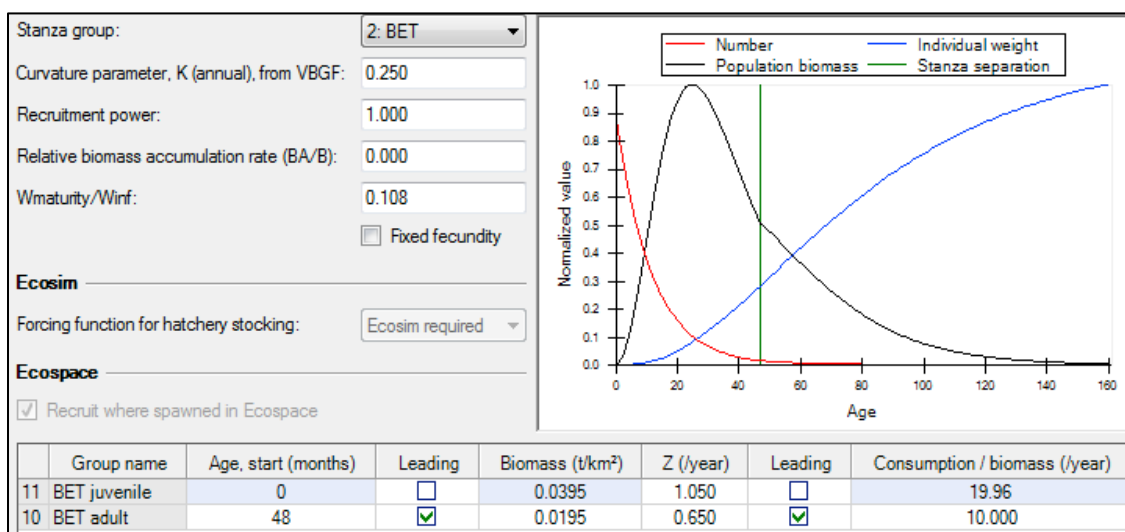

Figure 35. Multi-stanza routine within Ecopath to estimate parameters of non-leading stanza (juvenile bigeye).

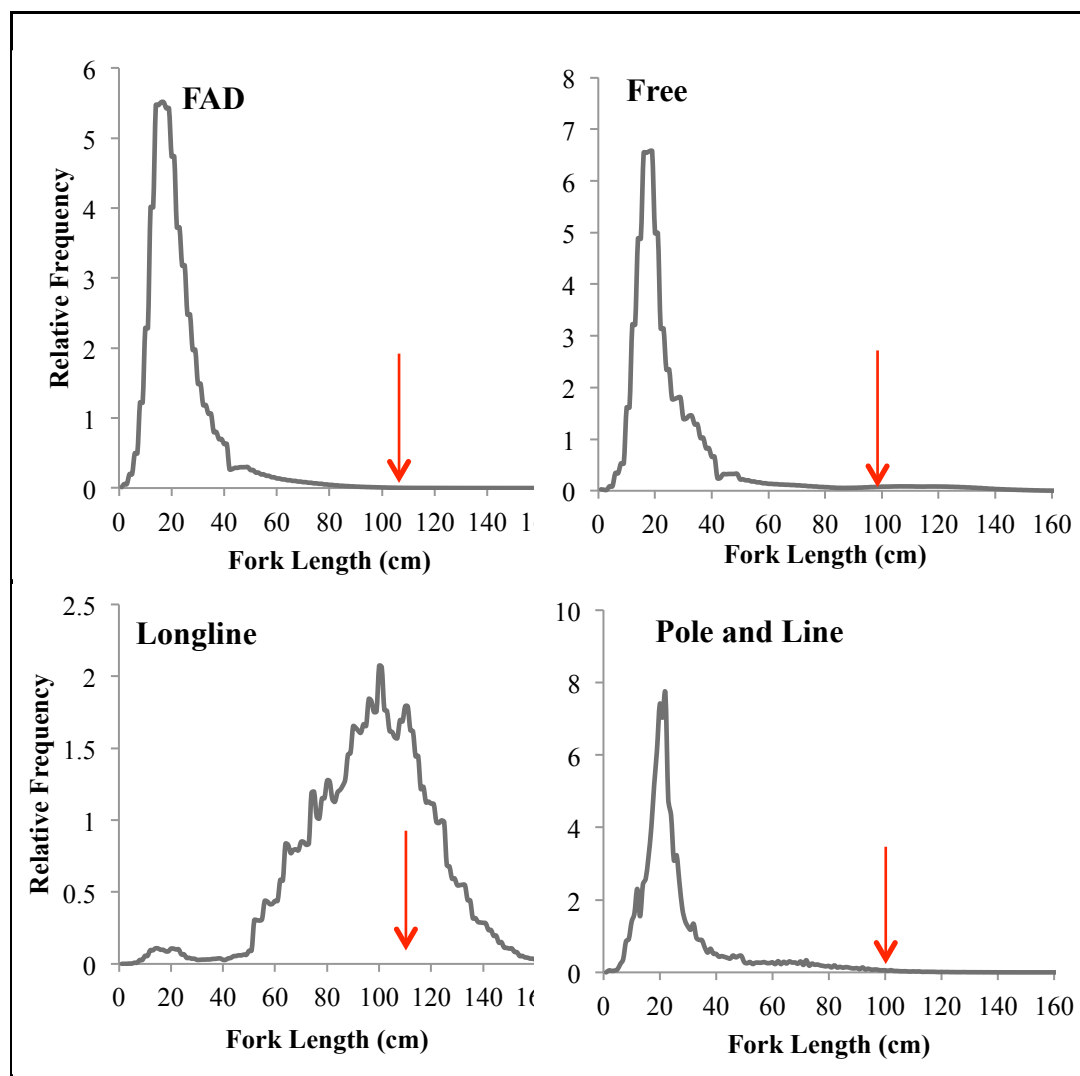

Figure 36. Size composition of catch of bigeye tuna by gear group. Red arrow represents size at maturity.

Albacore tuna

The biomass of albacore (*Thunnus alalunga*) was estimated from the most recent 2013 stock assessments of the North and South Atlantic stocks and scaled to the model area. It was assumed albacore only stay in the model area for 25% of the year as adults spawn tropical waters in Atlantic and this species rarely appears in the Task II and the observer databases (Anonymous, 2014c). Natural mortality was estimated at 0.4 /yr and fishing mortality at age results from the stock assessment show a range of 0.1 to 0.8, with the oldest age classes experiencing the highest fishing mortality. As the functional group was not split into ages, an average of the fishing mortality was used, 0.4 across the ages. The resulting initial P/B estimate was 0.8 year⁻¹. Q/B was estimated from the eastern Pacific Ecopath model (Olson and Watters, 2003). Diet of albacore tuna is made up of cephalopods, small tunas and other small teleost species (Cox et al. 2002b; Goñi et al. 2011). The diet of this functional group is also 45% imports due to its highly migratory nature (Cox *et al.*, 2002a).

Scombridae

The scombridae functional group is comprised of four species, wahoo (*Acanthocybium solandri*), (*Auxis thazard* and *A. rochei*) and (*Euthynnus alletteratus*). These species are characterized as fast growing, short lived with a high mortality (Jenkins and McBride 2009) Biomass estimates were developed from equation 3 using the observer database.

Table 29. Life history and input parameters for species within the Scombridae functional group.

Species	Weighting Factor	M yr ⁻¹	F yr ⁻¹	Aspect Ratio	Linf cm	K yr ⁻¹	Winf g	P/B yr ⁻¹	Q/B yr ⁻¹
<i>Acanthocybium solandri</i>	0.80	0.52	0.42	5.62	170	0.38	34,700	0.98	9.53
<i>Auxis thazard/rochei</i>	0.10	1.51	1.21	6.86	58	0.99	2,574	2.72	9.50
<i>Euthynnus alletteratus</i>	0.10	1.48	1.18	6.31	90	0.44	12,200	2.66	9.50

P/B was estimated using total instantaneous mortality (Z). Total instantaneous mortality is calculated from the sum of natural mortality and fishing mortality. M was estimated from the von Bertalanffy growth parameters (L_{∞} and K) using the natural mortality equation developed by Pauly (1980):

$$\log M = -0.0066 - 0.279 \log L_{\infty} + 0.6543 \log K + 0.4634 \log T$$

Equation 18

Where T corresponds to the mean habitat temperature. Q/B estimates were derived from life history parameters and the previously discussed empirically based equation (eq 7). (Kahraman *et al.*, 2011; Palomares and Pauly, 1989; Daniel Pauly, 1980).

The scombrids were assumed to be in the system the entire year and their diet was composed of flyingfish, cephalopods and other small pelagic teleosts (Vaske Júnior *et al.*, 2003)

Carangids

These species comprise the majority of the discards within the FAD associated purse-seine catch and have been well studied with in other ocean regions. Biomass estimates were obtained though the observer database using the average observed bycatch from 2003-2013 and by applying equation 3. As fishing mortality is unknown for these species, estimates were obtained by $F=0.8M$ (Griffiths, 2013).

Table 30. Life history and input parameters for species within the Carangid functional group

Species	Weighting Factor	M yr ⁻¹	F yr ⁻¹	Ar	L _∞ cm	K yr ⁻¹	W _∞ g	P/B yr ⁻¹	Q/B yr ⁻¹
<i>Caranx crysos</i>	0.26	0.71	0.57	4.19	70	0.35	2,314	1.28	10.31
<i>Elagatis bipinnulata</i>	0.73	0.55	0.44	3.59	180	0.35	46,200	0.99	10.80
<i>Naucrates ductor</i>	0.00	3.32	2.66	3.32	41	2.57	1,193	5.98	12.22
<i>Seriola rivoliana</i>	0.00	0.79	0.63	3.74	97	0.47	59,900	1.42	11.90
<i>Uraspis secunda</i>	0.01	0.47	0.38	4.24	139	0.25	2,000	0.85	13.11

Q/B estimates were obtained through life history values and equation 7 (Ramirez and Camila Posada, 2014). The diet composition were obtained through previously published reports (Anonymous, 2000; Goodwin and Johnson, 1986; Gunn, 1990; Ramirez and Camila Posada, 2014).

Coryphaena

The *Coryphaena* functional group is composed of the only 2 species in the genus, pompano (*Coryphaena equiselis*) and mahi-mahi *Coryphaena hippurus*, which are also the only species within the family. *C. hippurus* is the more common of the two dolphinfish and this is reflected in the observer database. The initial biomass was estimated using equation 3 as well as taking into account the large fishery that exists for

these fish. P/B and Q/B estimates were obtained from life history parameters and equations 5 and 7 (Castro *et al.*, 1999; Gibbs and Collette, 1959; Schwenke and Buckel, 2008).

Coryphaena are pelagic piscivores and their diet varies with location, including flying fish and halfbeaks (small epipelagics), smaller tunas and teleosts. Cannibalism of smaller sized dolphinfish also occurs and some of their diet was imported from outside the system (Castro *et al.*, 1999; Oxenford and Hunte, 1999; Taquet *et al.*, 2007).

Table 31. Life history parameters used to estimate M, P/B and Q/B for Coryphaena.

	Weighting Factor	M yr⁻¹	F yr⁻¹	Ar	Linf cm	K cm	P/B yr⁻¹	Q/B yr⁻¹
<i>Coryphaena equiselis</i>	0.01	1.00	0.80	3.42	127	1.34	1.80	7.03
<i>Coryphaena hippurus</i>	0.99	0.86	0.69	3.29	130	1.08	1.55	7.05

Balistidae

Three pelagic triggerfish species were included in the model, grey triggerfish (*Balistes capriscus*), spotted triggerfish (*Balistes punctatus*) and rough triggerfish (*Canthidermis maculata*), and of which the rough triggerfish, makes up the majority of the Balistidae functional group. There is very little information on the rough triggerfish, even though this species is often observed in very large schools around FADs (Forget *et al.*, 2015).

Balistidae biomass estimates were found using equation 4, P/B and Q/B were obtained through applied equations 5 and 7. The life history parameters were obtained through Fishbase.org (Froese and Pauly, 2015). These results were also compared to

other Ecopath models that contained triggerfish (Gasalla and Rossi-Wongtschowski, 2004). The diet of the Balistidae functional group was estimated from published reports and included small epipelagic fish as well as planktonic and encrusting crustaceans (Aggrey-Fynn, 2009; Moore, 1967; Santini *et al.*, 2013; Valle *et al.*, 2001).

Table 32. Life history parameters used to estimate M, F, P/B and Q/B for the Balistidae functional group.

Species	Weighting factor	M yr ⁻¹	F yr ⁻¹	Ar	Linf cm	K yr ⁻¹	W g	P/B yr ⁻¹	Q/B yr ⁻¹
<i>Balistes capriscus</i>	0.08	0.94	0.75	2.44	31	0.38	611	1.69	19.16
<i>Balistes punctatus</i>	0.01	0.50	0.40	1.98	60	0.19	1,800	0.89	8.70
<i>Canthidermis maculata</i>	0.91	0.59	0.47	2.02	52	0.23	3,085	1.05	7.85

Epipelagic I

The remainder of the epipelagic teleosts present in the observer database was split into 2 groups according to their prey preferences. The epipelagic I functional group contains piscivorous predators; *Lobotes surinamensis*, *Ruvettus pretiosus* and *Sphyræna barracuda*. The bycatch amounts of *Ruvettus pretiosus* is quite low and as a result the functional group is parameterized for *Lobotes surinamensis* and *Sphyræna barracuda*. Life history parameters used in equations 5 and 7 were found within published studies and Fishbase (Vasilakopoulos *et al.*, 2010).

The majority of their diet is composed of fish, including small epipelagic and mesopelagic species, as well as cephalopods and the largest of the zooplankton species (Franks *et al.*, 2003; Kalogirou *et al.*, 2012; Vasilakopoulos *et al.*, 2010).

Table 33. Life history parameters used to estimate M, F, P/B and Q/B for species contained within Epipelagic I.

Species	Weighting factor	M yr ⁻¹	F yr ⁻¹	Ar	L cm	K	W g	P/B yr ⁻¹	Q/B yr ⁻¹
<i>Lobotes surinamensis</i>	0.44	0.97	0.78	1.71	80		7,530	1.75	6.17
<i>Ruvettus pretiosus</i>	0.00	1.38	0.21	2.14	316	0.68	63,500	1.59	4.33
<i>Sphyræna barracuda</i>	0.55	0.27	0.22	1.61	165	0.10	57,800	0.49	3.99

Epipelagic II

Epipelagic II functional group contains species found in the bycatch database whose primary prey source includes crustaceans, copepods and encrusting algae which have been observed on and around floating objects (Dempster and Taquet, 2004).

Ranzania laevis, a type of sunfish, represented the largest component of this functional group within the bycatch, and life history parameters for all species in the group were obtained from Fishbase

Table 34. Life history and input parameters for species within the Epipelagic II functional group

Species	Weighting factor	M yr ⁻¹	F yr ⁻¹	Ar	Linf cm	K yr ⁻¹	Winf g	P/B yr ⁻¹	Q/B yr ⁻¹
<i>Ranzania laevis</i>	0.61	0.23	0.19	1	58	0.06	5,200	0.42	6.01
<i>Aluterus monoceros</i>	0.15	0.54	0.43	1.7	64	0.22	2,500	0.97	7.95
<i>Kyphosus sectatrix</i>	0.15	0.39	0.32	2.9	79	0.15	9,139	0.71	7.72
<i>Remora remora</i>	0.00	0.32	0.26	1.6	79		2,077	0.58	8.10

Small Epipelagics

The small epipelagic functional group is made up of 12 species. The most important component of this group, *Vinciguerria nimbaria*, was grouped separately as a functional group in the original PICOLO model as it was identified as a major component of the tuna species' diet. However, up to date information on the biomass of this species

is not available so this species could not be separated out as a single species functional group. While this species is a mesopelagic fish, the original model assumed the species stayed within the epipelagic zone because of evidence found on contents of tuna stomachs (Figure 37). The remainder of the small epipelagic group is made up of several species of flying fish and halfbeaks.

Table 35. Life history parameters used to estimate P/B and Q/B for small epipelagics

Species	M yr ⁻¹	F yr ⁻¹	L _∞ cm	K yr ⁻¹	P/B yr ⁻¹	Q/B yr ⁻¹
<i>Cheilopogon cyanopterus</i>	1.63	1.31	29.9	0.87	2.94	11.3
<i>Cheilopogon melanurus</i>	1.74	1.39	33.5	1.01	3.14	13.1
<i>Cheilopogon milleri</i>	1.72	1.37	29.9	0.94	3.09	21.4
<i>Cheilopogon nigricans</i>	2.83	2.26	22.2	1.69	5.09	13.6
<i>C. pinnatibarbus</i>	1.28	1.02	41.7	0.69	2.3	7.9
<i>Fodiator acutus</i>	2.79	2.23	19	1.73	5.02	28.3
<i>Hirundichthys affinis</i>	2.76	2.21	29.9	1.94	4.96	8.7
<i>Oxyporhamphus micropterus</i>	1.91	1.53	23	0.99	3.44	13.8
<i>Parexocoetus brachypterus</i>	3.49	2.8	21.1	2.4	6.29	15
<i>Prognichthys gibbifrons</i>	2.26	1.81	20.6	1.22	4.07	26.9
<i>Vinciguerria nimbaria</i>					8.03	29.2

Biomass was estimated from the PICCOLO model and the observer database using equation 3. There was very little presence of these species within the observer database as they are too small to be constrained by the purse seine net. Therefore, biomass levels were heavily influenced by biomass in the PICCOLO model. Small epipelagic species' P/B and Q/B were found from previously published models and values obtained through Fishbase (Griffiths, 2013). The final small epipelagic P/B and Q/B were calculated from the weighted combination of small epipelagics and *V. nimbaria*

from the original PICCOLO model (Schultz, 2001). The diet of this group is dominated by zooplankton species as well as small teleosts also found within the small epipelagic group (Lebourges-Dhaussy *et al.*, 2000).

Small mesopelagics

The original PICCOLO model was developed using data collected from cruises conducted within the South Sherbro Area in the 1990's. There is a lack of new data from this region so it was assumed that biomass, P/B and Q/B values are the same as those from the PICCOLO model. The migration rate in Figure 37 was estimated using acoustic data and knowledge of the species behaviour (Lebourges-Dhaussy *et al.*, 2000; Schultz, 2001).

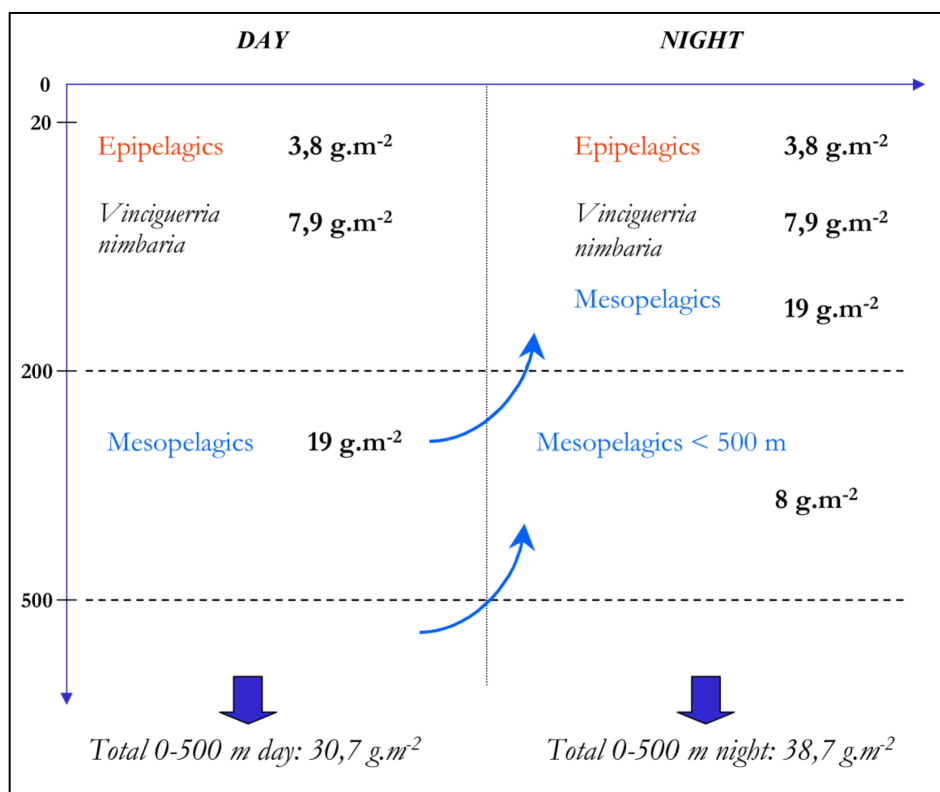

Figure 37. Figure from original PICCOLO model calculating biomass of mesopelagics due to diel vertical migration Source: Schultz, 2001.

Cephalopods

Biomass estimates taken from original PICOLO model. The initial biomass estimates of the PICOLO model were taken from trawl surveys (Schultz and Menard, 2003). The P/B and Q/B estimates from the original model were updated using published values of 3.5 and 17 (Coll *et al.*, 2013; Croxall and Prince, 1996). Cephalopods prey on a mixture of small epipelagics, small mesopelagics, other squids and macrozooplankton.

Gelatinous

The gelatinous functional group makes up jellyfish species found within the region. The original biomass value derived from the PICOLO cruises were used for the Gulf of Guinea model. The original P/B and Q/B parameter values were much lower than other published values from Ecopath models. The initial parameter estimates used were obtained through a published values (Pauly *et al.*, 2009). The major predator of jellyfish are leatherback turtles, which make up a large component of the sea turtle functional group.

Zooplankton groups

The information for these three functional groups comes from studies conducted in the 1980s (Roger, 1982, Le Borgne, 1982, Le Borgne et al, 1983). The macrozooplankton group, sized from 0.2 to 10 cm, is composed of crustaceans, fish larvae and small mollusks. The standing biomass of this group was estimated at 4.2 t/km², with a P/B value 10 per year and a Q/B value of 31.70 per year (Schultz and Menard, 2003; Schultz, 2001). Diet was split between mesozooplankton and phytoplankton.

The mesozooplankton functional group, sized 200-500 μm , is composed of copepods and the standing biomass was estimated at 24 t/km^2 , while P/B and P/Q were estimated at 53 year^{-1} and 31% respectively. From this, Q/B was estimated by the model. Diet was split between microzooplankton, phytoplankton and detritus.

The standing biomass of the microzooplankton, those sized 50-200 μm , was 2 t/km^2 . This functional groups is made up copepod larvae, foraminifera, radiolarians, tintinnids and pteropods. P/B estimates ranged from 124 to 840 a year while P/Q values ranged form 37-40% of the gross efficiency. From this Q/B was estimated. Diet was partitioned into phytoplankton, bacteria (detritus) and microzooplankton (Shannon and Jarre-Teichmann, 1999).

Phytoplankton

The phytoplankton functional group parameterization comes from the PICOLO cruises that were conducted in the 1990s in the South Sherbro Area. There have been no subsequent cruises to estimate the phytoplankton in the area so the estimates from the 1990s are used in the Gulf of Guinea model. The primary production for the region was estimated at 1 $\text{mg of C m}^3 \text{h}^{-1}$, yielding a production of 7,490 t of C per km^2 . This is a similar value estimate by an open ocean circulation model (Schultz and Menard, 2003; Schultz, 2001). Using the production for the region, the biomass of the phytoplankton was found using a biogeochemical model. Biomass was set at 37 t/km^2 and P/B was 200 yr^{-1} . Obviously, there is no consumption to biomass ratio for primary producers.

Detritus

There was no available information in the PICOLO model and this model utilizes the same estimation for the detritus pool as the PICOLO model. The detritus group can be seen as the bacteria and microbial loop portion of the model. The standing stock of the detritus can be found using a model derived by Christensen and Pauly (1993).

$$D = -2.41 + 0.954 \log_{10} PP + 0.863 \log_{10} E \quad \text{Equation 19}$$

where D is the detritus standing stock measured in g C/m^2 , PP is primary production and E is the euphotic zone depth. In the case of the Gulf of Guinea, it was set at 60m.

Fisheries

The landing information for longline and baitboat (pole and line) fisheries were found using values in the ICCAT Task I database while the landings from purse seine free and purse seine FAD sets were estimated from the ICCAT Task II database. There are no records of longline or baitboat catches of albacore tuna occurring in the model area, however both the FAD and free-school purse-seine fleets catch them. Small amounts of albacore are also listed in the observer database as retained bycatch.

Table 36. Fisheries and reported landings ($\text{t km}^{-2} \text{yr}^{-1}$) in the model area.

	Group name	Free PS	FAD PS	Baitboat	Longline	Total
2	Sharks				0.0022	0.0022
6	Billfish				0.0003	0.0003
7	Skipjack	0.0059	0.0236	0.0081	0.0000	0.0376
8	YFT adult	0.0046			0.0002	0.0048
9	YFT juvenile	0.0058	0.0027	0.0021	0.0002	0.0108
10	BET adult	0.0000	0.0000	0.0004	0.0018	0.0023
11	BET juvenile	0.0008	0.0026	0.0014	0.0006	0.0054
12	Albacore	0.0000	0.0000			0.0001
13	Scombridae	0.0000	0.0004			0.0004

Discards

For the FAD and the free school purse seine fishery, discard amounts for each functional group was calculated from observer database using the collapsed ratio estimator method (Chapter 2). The collapsed ratio estimator was applied to the total landings from the entire purse seine fleet, not just the EU vessels from the database. This method represents a slight shift from the method utilized in Chapter 2 as the auxiliary variable for the estimates obtained was the total landings of the EU tuna purse seine fleet.

Discard amounts for the baitboat fishery was estimated from the published estimates and the ICCAT manual (ICCAT 2006-2015). Longline discard amounts were estimated from the literature (Carranza *et al.*, 2006; Davies *et al.*, 2009; Minami *et al.*, 2007; Ortiz and Arocha, 2004; Restrepo *et al.*, 2003).

Table 37. Discards ($t\ km^{-2}\ yr^{-1}$) by fleet and total discards for each functional group

Group name	Free PS	FAD PS	Baitboat	Longline	Total
1 Seabirds				0.0002	0.0002
2 Sharks	0.0001	0.0001		0.0002	0.0003
4 Rays		0.0001	0.0001		0.0002
5 Sea turtles				0.0004	0.0001
6 Billfish	0.0001	0.0002			0.0004
7 Skipjack	0.0002	0.0028			0.0002
8 YFT adult	0.0001				0.0030
9 YFT juvenile		0.0028			0.0001
10 BET adult	0.0002				0.0028
11 BET juvenile		0.0022			0.0002
12 Albacore					0.0022
13 Scombridae	0.0002	0.0016	4.70E-06		1.00E-06
14 Carangidae		0.0003			0.0017
15 Coryphaena		0.0001			0.0003
16 Balistidae		0.0003			0.0001
17 Epipelagic I		3.40E-05			0.0004
18 Epipelagic II		0.0001			3.83E-05
19 Sm. epipelagics	1.64E-07			2.00E-07	7.64E-05
20 Sm. mesopelagics		8.25E-08			

Discard Mortality Rate

The discard mortality rate for the free and FAD purse seine fisheries was calculated from the observer databases where fate was recorded. The proportion of living discards to dead discards and bycatch retained onboard for use of the crew was found and applied to the overall relevant functional group. Except in the case of the Balistidae functional group, species that were discarded alive were assumed to have no post-release mortality. Experiments conducted on Balistidae to determine post-release mortality informed discard fate for the functional group (Forrestal, in prep).

Table 38. Discard mortality rate for functional groups caught as discards.

Group name	Free PS	FAD PS	Baitboat	Longline
0 Seabirds				1
1 Sharks	0.925	0.705	1	1
3 Rays	0.733	0.801	1	1
4 Sea turtles	0.044	0.016		1
5 Billfish	0.995	0.998		1
6 Skipjack	1	1	1	1
7 YFT adult	1	1	1	1
8 YFT juvenile	1	1	1	1
9 BET adult	1	1	1	1
10 BET juvenile	1	1	1	1
11 Albacore	1	1		
12 Scombridae	1	0.999	1	
13 Carangidae	0.99	0.946		
14 Coryphaena	0.997	0.993		
15 Balistidae	0.9	0.86		
16 Epipelagic I	1	0.993		
17 Epipelagic II	0.044	0.545		
18 Small epipelagics	0.6	1		
19 Small mesopelagics	1			

For longline and baitboat fisheries, the discard mortality rate was set at 1, meaning all functional groups caught as discards, were dead discards. Discards caught onboard baitboat vessels are generally retained onboard for the crew or sold in the “*faux poisson*” markets. Dead discards were assumed to enter the detritus pool of the system.

Model Analysis

The model was considered balanced when the ecotrophic efficiencies were below 1 and the P/Q values were considered reasonable, between 0.05 and 0.3. Species that are either heavily exploited by fisheries or have high predation rates have an EE value very close to 1. This signifies that the majority of their biomass is consumed within the model area as ecotrophic efficiencies represent the fraction of the functional group utilized within the system. Those functional groups with few predators or containing species that are very small and abundant such as zooplankton groups have a lower EE value, closer to 0.1 or 0.3. The production to consumption parameter (P/Q) calculated by Ecopath was also assessed. The P/Q parameter represents the gross food conversation efficiency and biologically realistic values range from 0.05-0.3 (Christensen and Walters, 2004).

The balanced ecosystem model was evaluated using ecological indices to describe trophic flows and overall ecosystem health. The trophic levels of all functional groups were calculated within the model based on the diet matrix, and from there, trophic efficiencies between the trophic levels were calculated. The total trophic flows, Total System Throughput (TST), were quantified by consumption, respiration, production, exports and imports as well as the flows to detritus. The TST can be seen as a proxy of the size of the modeled ecosystem (Coll *et al.*, 2007).

Certainty of each input value for all the functional groups were assigned pedigree values to calculate an overall pedigree index of the model. Values are assigned on a scale of 0-1, depending on the source of the data. Parameter values obtained empirically from the region the model describes have the highest values while “guestimates” are at the lower end of the spectrum. The resulting index was compared to other published models. Confidence values obtained from the pedigree index were used to assign an upper and lower bound for each of the inputs for all functional groups. A Monte Carlo simulation run from 20 trials of the base Ecopath model was used to find the best fits for parameter estimates (Kavanagh *et al.*, 2004).

The mixed trophic impact (MTI) quantifies the direct and indirect trophic interactions between functional groups. It describes the positive or negative impacts of a hypothetical increase in biomass of a functional on the other functional groups. From the MTI data, the total mixed trophic impact of each functional group was found. The impacts of one functional group on all the other functional groups in the model were summed together, weighted by the inverse of each impacted group’s biomass. This measurement provides an indication of the effect of what one unit of change in the impacting functional group’s biomass will have on the predicted biomass of all the other groups within the system (Libralato *et al.*, 2004).

Odum’s ecological indicators of ecosystem development theory were also examined, including Finn’s Cycling Index and the System Omnivory Index. These indicators will be used in Ecosim scenarios to assess changes to the modeled ecosystem (Margalef, 1968; Odum, 1969; Coll *et al.* 2007).

The model was also assessed for thermodynamic stability. This was determined through regressions of longevity against trophic level as well as trophic level against the respiration to assimilation ratio relationships. It is assumed that longer-lived species will have higher trophic levels. As a proxy for longevity, the natural log of biomass over production was used. The second regression is based off the assumption that species with a higher trophic level will have a respiration to assimilation ratio close to one, as high level trophic level predators should have low production.

Results

Data Inputs

In order for the model to balance, P/B and the diet composition matrix were adjusted from the originally calculated values (Table 39 and Table 41). Biomass estimates taken from applying equation 3 to the observer database were increased as it was assumed that some of these species were underestimated in the bycatch. In the case of this model, EE values were reasonable, given the level of predation and the fisheries that exist in the model. Marine mammals had a very low EE of 0.003 but this functional group was mainly comprised of very large whales that are neither predated on nor fished in the Gulf of Guinea. The P/Q values were biologically realistic for the majority of the species with the exception of marine mammals (P/Q=0.004).

Confidence values for all input parameters were obtained through the pedigree index (Table 40). The largest uncertainty (0.40) for all input parameters was in the biomass estimates for marine mammals, rays, sea turtles, small epipelagics, small

mesopelagics, cephalopods and gelatinous functional groups. The largest CV for P/B and Q/B estimates was seen in the same functional groups as biomass but with a lower uncertainty than was found in the biomass estimates (0.30). The overall Pedigree Index of the model was 0.364, which is in the lower 42% of published Ecopath models (Morissette, 2007).

Trophic Flows and Ecosystem Indicators

The flows between functional groups and trophic levels were quantified and visualized with the trophic flow diagram and Lindeman Spine diagram (Figure 38 and Figure 39). The Lindeman Spine depicts trophic level flow in the Gulf of Guinea. The principal flow between trophic level occurs between TL I, II and III. In the model, trophic level I makes up 71% of the Total System Throughput (TST). This value was reached by combining the TST of detritus to TL II and the TST of the Primary Producers (TL I) to TL II. The TST from TL II to TL III makes up 25%, followed by 3% of TL III to TL IV. The geometric mean Transfer Efficiency between trophic levels was calculated as 11

Table 39. Final input parameters for Gulf of Guinea model. Values in bold represent parameters estimated by Ecopath.

Group number	Group name	Trophic level	Biomass (t/km ²)	P/B (yr ⁻¹)	Q/B (yr ⁻¹)	EE (yr ⁻¹)	P/Q (yr ⁻¹)
1	Seabirds	4.853	0.006	0.075	73.026	0.452	0.001
2	Sharks	5.407	0.008	0.570	3.500	0.555	0.163
3	Marine mammals	3.445	0.042	0.020	4.780	0.003	0.004
4	Rays	3.192	0.007	0.250	3.900	0.244	0.064
5	Sea turtles	3.408	0.003	0.250	3.900	0.561	0.064
6	Billfish	5.446	0.002	0.840	6.110	0.403	0.137
7	Skipjack	4.655	0.202	1.880	16.900	0.222	0.111
8	YFT adult	5.336	0.030	1.400	11.640	0.120	0.120
9	YFT juvenile	4.681	0.076	1.200	21.619	0.745	0.056
10	BET adult	5.125	0.020	0.650	10.000	0.180	0.065
11	BET juvenile	4.623	0.039	1.050	19.964	0.974	0.053
12	Albacore	4.404	0.001	0.550	9.800	0.506	0.056
13	Scombridae	4.322	0.077	1.420	9.530	0.934	0.149
14	Carangidae	4.163	0.001	1.650	10.670	0.834	0.155
15	Coryphaena	4.766	0.006	1.550	7.050	0.442	0.220
16	Balistidae	4.274	0.018	1.100	8.740	0.706	0.126
17	Epipelagic I	4.205	0.003	1.140	2.750	0.921	0.415
18	Epipelagic II	2.817	0.004	0.500	5.970	0.861	0.084
19	Sm. epipelagics	3.507	3.948	7.530	26.490	0.985	0.284
20	Sm. mesopelagics	3.111	11.660	1.530	11.000	0.539	0.139
21	Cephalopods	4.201	1.900	3.500	17.000	0.763	0.206
22	Gelatinous	2.389	7.500	5.000	25.000	0.837	0.200
23	Macrozooplankton	2.444	4.200	10.000	31.700	0.978	0.315
24	Mesozooplankton	2.111	24.000	53.000	170.968	0.199	0.310
25	Microzooplankton	2.111	2.000	450.00	818.182	0.659	0.550
26	Phytoplankton	1.000	37.000	200.00		0.409	
27	Fishery discards	1.000	0.012				
28	Detritus	1.000	488.000			0.309	

Table 40. Results of Monte Carlo trials using confidence values derived from Pedigree Index for the biomass, P/B and Q/B input parameters.

Group name	CV	Lower	Biomass	Upper	CV	Lower	P/B	Upper	CV	Lower	Q/B	Upper
1 Seabirds	0.25	0.00	0.01	0.01	0.20	0.04	0.07	0.10	0.20	43.82	73.03	102.24
2 Sharks	0.25	0.00	0.01	0.01	0.15	0.40	0.57	0.74	0.15	2.45	3.50	4.55
3 Marine mammals	0.40	0.01	0.04	0.08	0.10	0.02	0.02	0.02	0.30	1.91	4.78	7.65
4 Rays	0.40	0.00	0.01	0.01	0.30	0.10	0.25	0.40	0.30	1.56	3.90	6.24
5 Sea turtles	0.40	0.00	0.00	0.01	0.30	0.10	0.25	0.40	0.30	1.56	3.90	6.24
6 Billfish	0.25	0.00	0.00	0.00	0.20	0.50	0.84	1.18	0.20	3.67	6.11	8.55
7 Skipjack	0.25	0.10	0.20	0.30	0.10	1.50	1.88	2.26	0.10	13.52	16.90	20.28
8 YFT adult	0.25	0.01	0.03	0.04	0.10	1.12	1.40	1.68	0.10	9.31	11.64	13.97
9 YFT juvenile	0.25	0.04	0.08	0.11	0.25	0.60	1.20	1.80	0.25	10.81	21.62	32.43
10 BET adult	0.25	0.01	0.02	0.03	0.10	0.52	0.65	0.78	0.10	8.00	10.00	12.00
11 BET juvenile	0.25	0.02	0.04	0.06	0.25	0.53	1.05	1.58	0.25	9.98	19.96	29.95
12 Albacore	0.25	0.00	0.00	0.00	0.25	0.28	0.55	0.83	0.25	4.90	9.80	14.70
13 Scombridae	0.25	0.04	0.08	0.12	0.25	0.71	1.42	2.13	0.25	4.77	9.53	14.30
14 Carangidae	0.25	0.00	0.00	0.00	0.25	0.83	1.65	2.48	0.25	5.34	10.67	16.01
15 Coryphaena	0.25	0.00	0.01	0.01	0.25	0.78	1.55	2.33	0.25	3.53	7.05	10.58
16 Balistidae	0.25	0.01	0.02	0.03	0.25	0.55	1.10	1.65	0.25	4.37	8.74	13.11
17 Epipelagic I	0.25	0.00	0.00	0.00	0.25	0.57	1.14	1.71	0.25	1.38	2.75	4.13
18 Epipelagic II	0.25	0.00	0.00	0.01	0.25	0.25	0.50	0.75	0.25	2.99	5.97	8.96
19 Sm. epipelagics	0.40	0.79	3.95	7.11	0.25	3.77	7.53	11.30	0.25	13.25	26.49	39.74
20 Sm. mesopelagics	0.40	2.33	11.66	20.99	0.30	0.61	1.53	2.45	0.30	4.40	11.00	17.60
21 Cephalopods	0.40	0.38	1.90	3.42	0.30	1.40	3.50	5.60	0.30	6.80	17.00	27.20
22 Gelatinous	0.40	1.50	7.50	13.50	0.30	2.00	5.00	8.00	0.30	10.00	25.00	40.00
23 Macrozooplankton	0.25	2.10	4.20	6.30	0.15	7.00	10.00	13.00	0.15	22.19	31.70	41.21
24 Mesozooplankton	0.25	12.00	24.00	36.00	0.15	37.10	53.00	68.90	0.15	119.68	170.97	222.26
25 Microzooplankton	0.25	1.00	2.00	3.00	0.15	315.00	450.00	585.00				
26 Phytoplankton	0.25	18.50	37.00	55.50	0.15	140.00	200.00	260.00				

Table 41. Diet composition matrix with prey (row) and predator (column) with import amount.

Prey \ predator	1	2	3	4	5	6	7	8	9	10	11	12	13	14	15	16	17	18	19	20	21	22	23	24	25															
1 Seabirds		0.000																																						
2 Sharks			0.003																																					
3 Marine mammals				0.000																																				
4 Rays					0.010																																			
5 Sea turtles						0.000																																		
6 Billfish							0.000																																	
7 Skipjack								0.145		0.150		0.100		0.100																										
8 YFT adult									0.005																															
9 YFT juvenile										0.130		0.179		0.090		0.090																								
10 BET adult											0.005																													
11 BET juvenile												0.100		0.100		0.084																								
12 Albacore													0.001		0.010																									
13 Scombridae														0.200	0.140	0.000	0.200		0.100		0.050					0.080														
14 Carangidae															0.025	0.001		0.040			0.050					0.002														
15 Coryphaena																0.001		0.186								0.050														
16 Balistidae																	0.270		0.001							0.130														
17 Epipelagic I																		0.001								0.075														
18 Epipelagic II																			0.050		0.003		0.001																	
19 Sm. epipelagics																				0.224	0.023		0.075		0.010	0.353	0.092	0.450	0.196	0.500	0.100	0.216	0.202	0.275	0.202	0.302		0.150		0.340
20 Sm. mesopelagics																					0.001	0.020																		
21 Cephalopods																																								
22 Gelatinous																																								
23 Macrozooplankton																																								
24 Mesozooplankton																																								
25 Microzooplankton																																								
26 Phytoplankton																																								
27 Fishery discards																																								
28 Detritus																																								
29 Import																																								

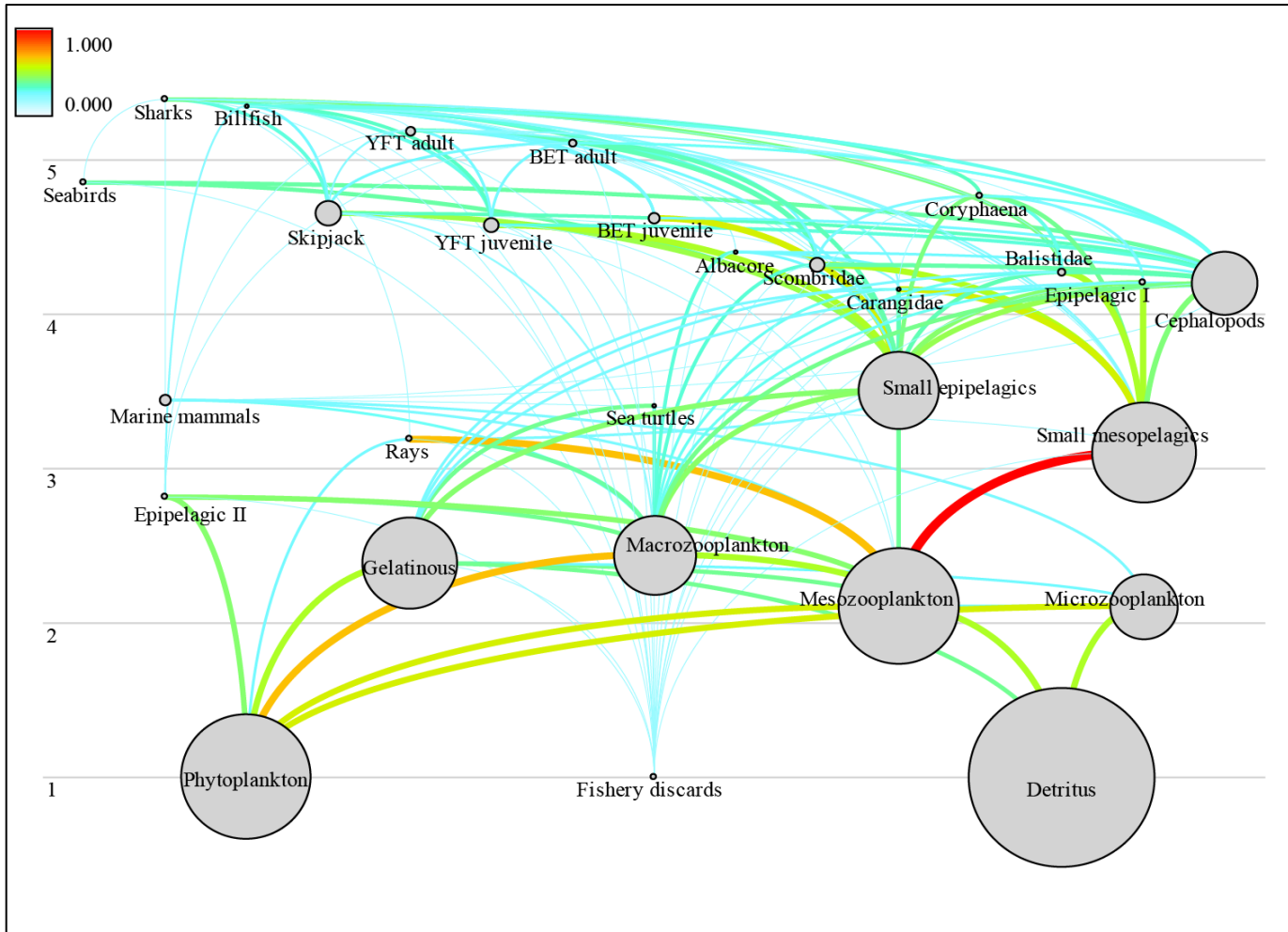

Figure 38. Trophic flow diagram showing the connections between the functional groups of the Gulf of Guinea model. Colored lines denote the relative proportion of each predator's diet

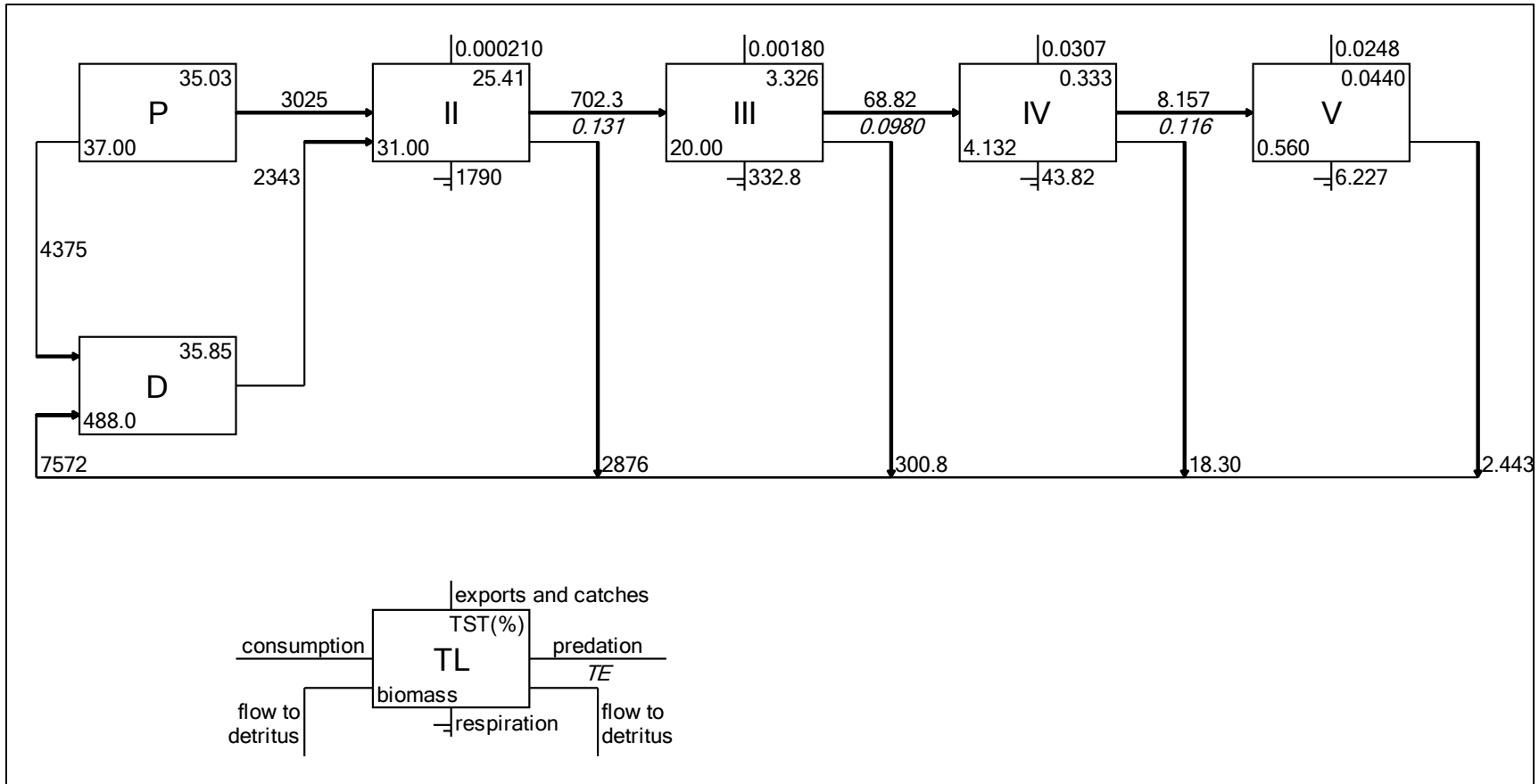

Figure 39. Lindeman Spine diagram quantifying the trophic flows between each trophic level, legend showing destination of each component of biomass. Biomass flows in $t/km^2/yr$.

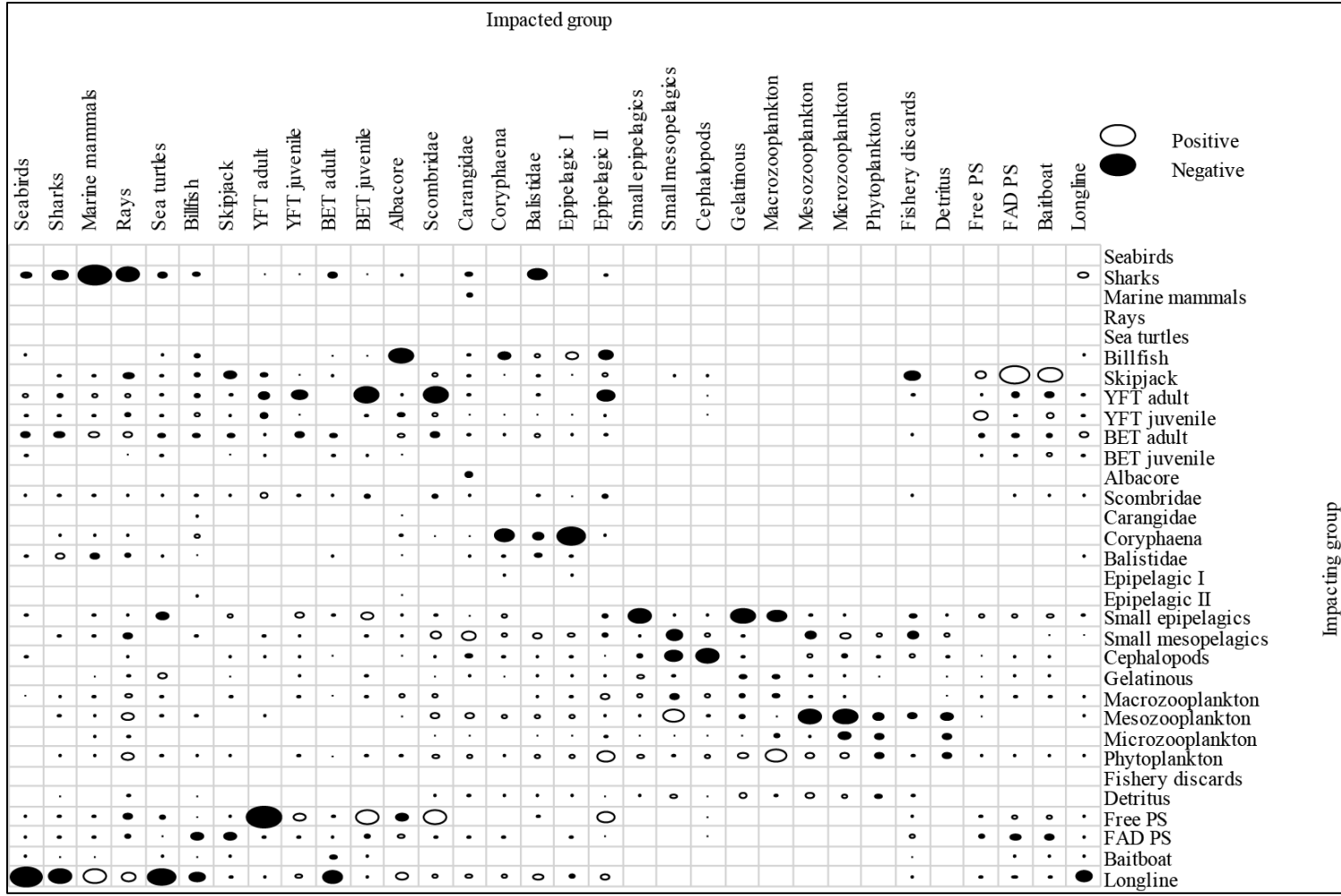

Figure 40. Graphical results of the Mixed Trophic Impact analysis. Impacting groups are on the vertical axis while I impacted groups are on the horizontal axis. The size and color of the ovals represents the magnitude and nature of the impacts between functional groups.

The mixed trophic impact of each functional group was used as a sensitivity analysis to quantify the negative and positive trophic interactions between functional groups (Figure 40). Some of the largest interactions were seen between the fisheries and functional groups that make up the catch and bycatch of those fisheries. The major negative interactions were the result of predator-prey relationships as expected. The results of the Total Mixed Trophic Impacts are shown in Figure 9. Billfish, sharks, Coryphaena, YFT juveniles and skipjack have the largest negative impact of varying their biomasses while the macro- and mesozooplankton, small epipelagics and phytoplankton have the largest positive impacts of varying their biomass.

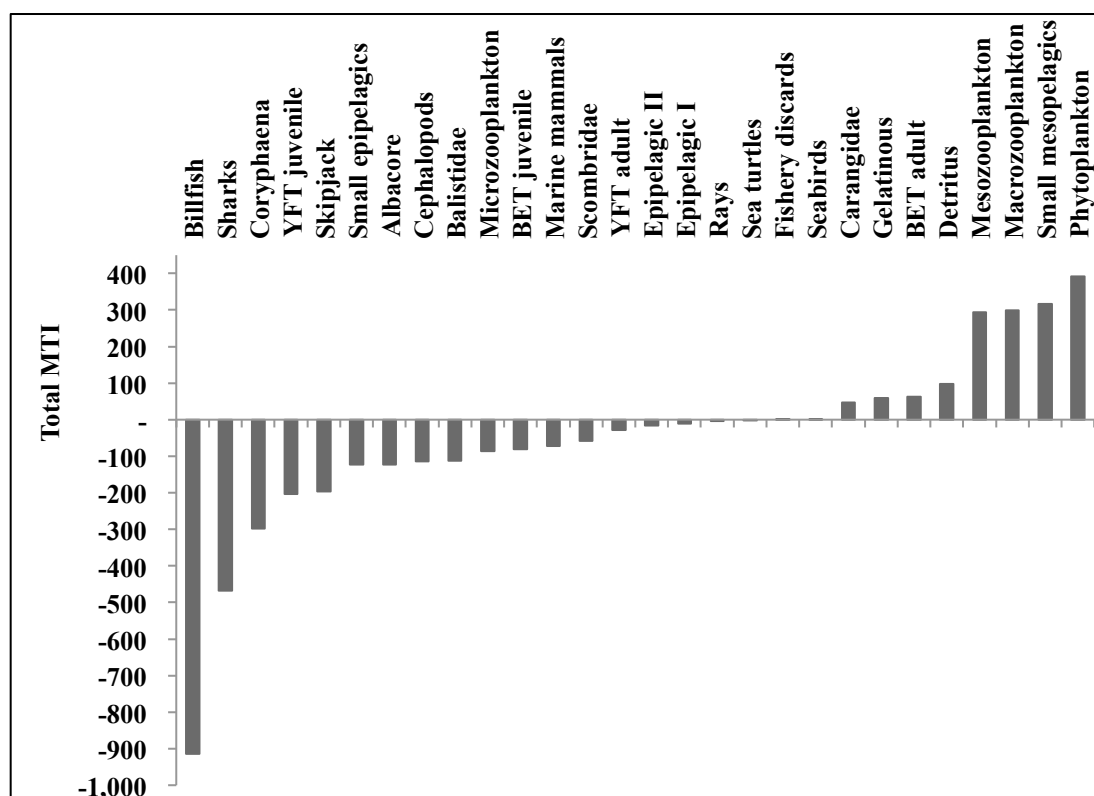

Figure 41. Total MTI results of impacting functional groups on the remaining groups.

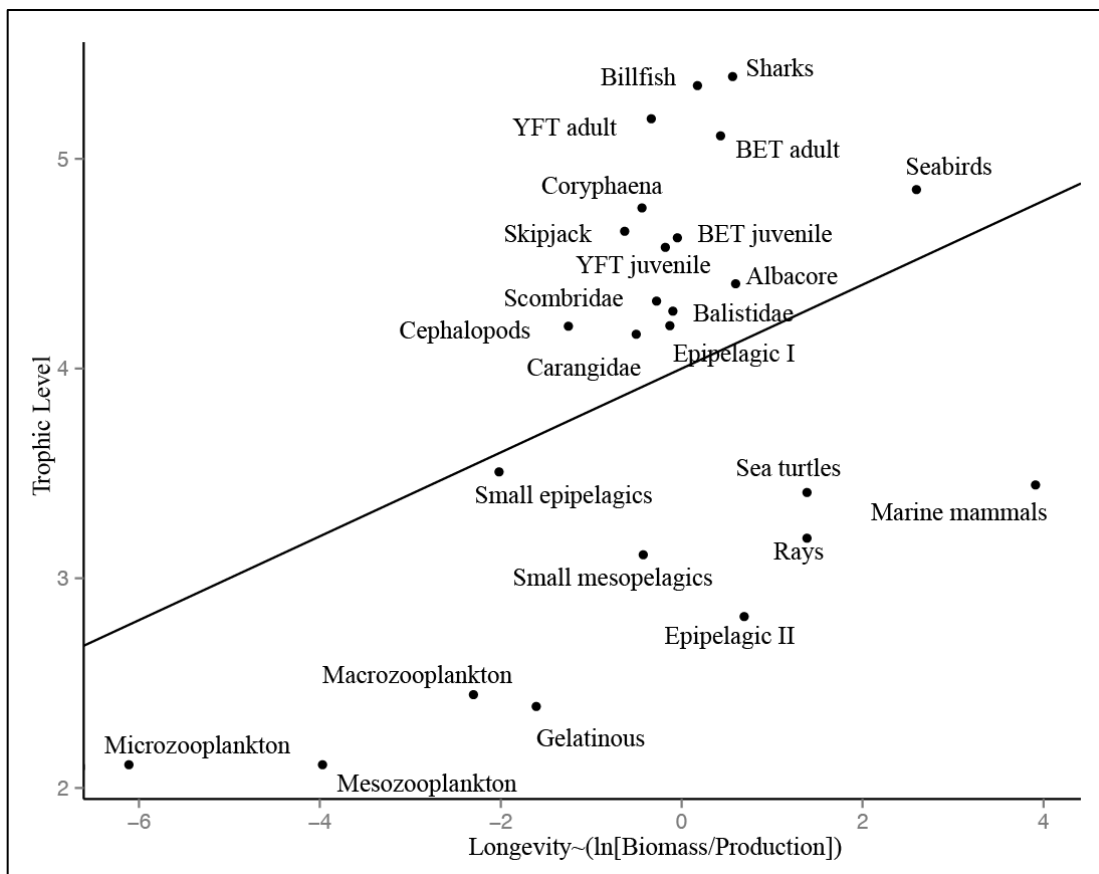

Figure 42. Regression of the longevity of each functional group against their respective trophic levels used to assess thermodynamic stability.

There is a positive relationship between the longevity and trophic levels of the functional groups (Figure 41). There is also a positive relationship between the trophic levels of the functional groups and the respiration to assimilation ratio (Figure 12). The implications of these regressions are that the model thermodynamically stable, biologically realistic and consistent with the theoretical basis of Ecopath.

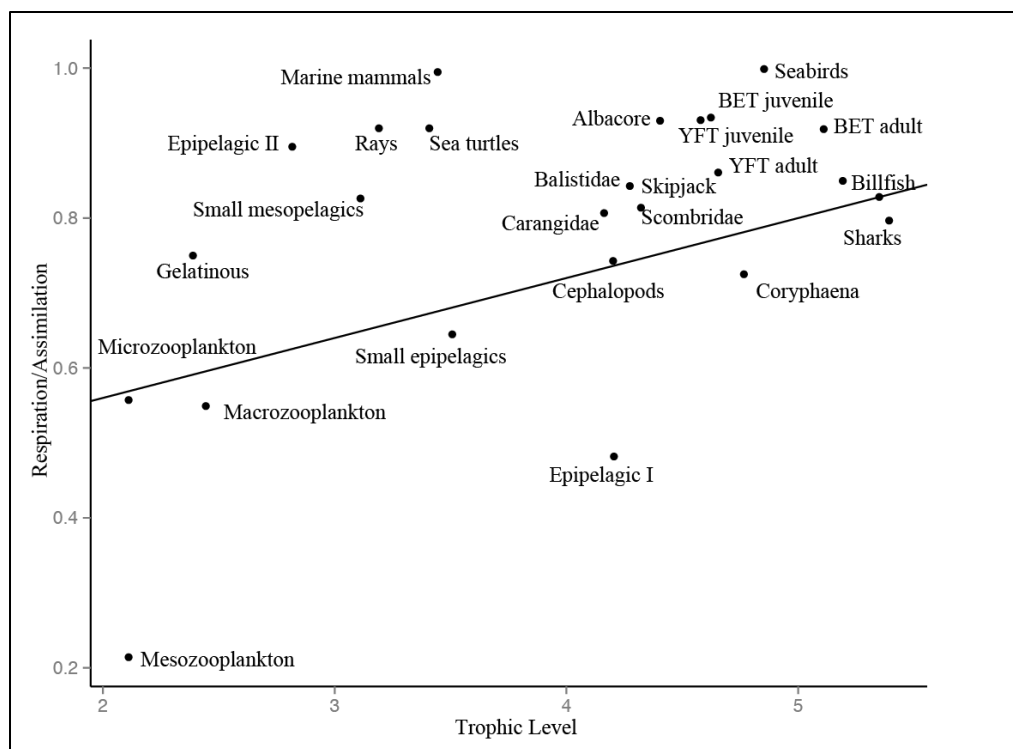

Figure 43. Regression of the trophic levels of each functional group against their respiration to assimilation ratio used to assess thermodynamic stability.

The sum of flows into detritus dominated the Total System Throughput (36%) followed by the total consumption (30%) and then flows to exports (25%) (Table 42). Consumption of production split by functional groups shows that mesozooplankton (65%) and microzooplankton (26%) dominate the consumption in the system (Figure 43A). The largest consumption of production of functional groups that are caught by the fisheries in the system is from skipjack (48%), followed by juvenile yellowfin tuna (23%) (Figure 43B).

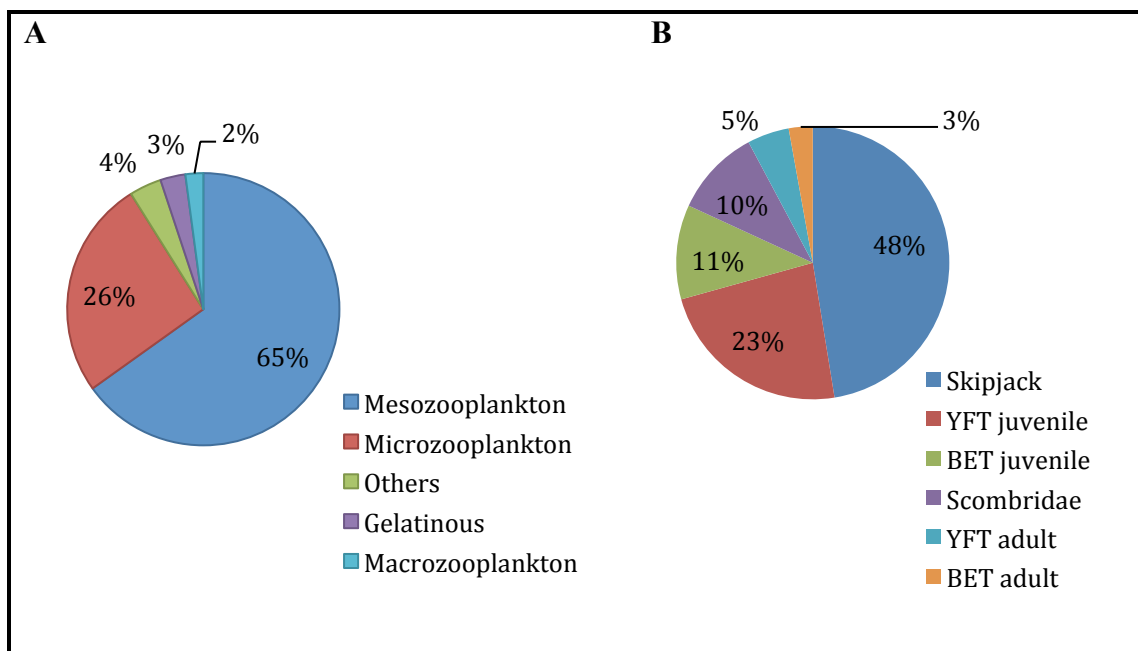

Figure 44. Partitioning of consumption of production in the system for all functional groups (A) and the consumption of the production by fished functional groups (consumption \geq 2%).

The system statistics were compared to the results from the PICOLO model from the early 1990s to determine differences between the two ecosystems. The total system throughput, which can be seen as the size of the ecosystem, is greater in the Gulf of Guinea model than the PICOLO. This is reasonable as the total size of the model is greater than the PICOLO modeled area. The omnivory index was estimated at 55%, compared to 34% from the PICOLO model showing an increase in the complexity between trophic levels. However, this is most likely an artifact of the model as the PICOLO model had fewer functional groups than the current model. The total primary production required to maintain the fishery was estimated at 3.2%, a slight decrease from the PICOLO model (4%).

Table 42. Summary statistics and indices of the Gulf of Guinea and the comparison of statistics from previous PICOLO model.

Statistics and Flows	GoG	PICOLO	Units
Sum of all consumption	6,333.43	7,361.00	t/km ² /yr
Sum of all exports	5,229.99	4,507.00	t/km ² /yr
Sum of all respiratory flows	2,173.03	2,894.00	t/km ² /yr
Sum of all flows into detritus	7,572.66	7,133.00	t/km ² /yr
Total system throughput	21,309.10	21,897.00	t/km ² /yr
Sum of all production	9,706.44	9,734.00	t/km ² /yr
Calculated total net primary production	7,400.00	7,400.00	t/km ² /yr
Total primary production/total respiration	3.41		
Net system production	5,226.97	4,505.00	t/km ² /yr
Total primary production/total biomass	79.782		
Total biomass (excluding detritus)	92.75	115.65	t/km ²
Total Transfer Efficiency	11.4		%
Total catch	0.06	0.08	t/km ² /yr
Mean trophic level of the catch	4.68	4.43	
Primary production required to sustain catch	3.18	4.00	%
Gross efficiency of the fishery (catch/net pp)	1.03E-5	1.10E-5	
Ecopath Pedigree Index	0.36		
Network flow indices			
System Omnivory Index	0.55	0.34	
Throughput cycled	183.1		t/km ² /yr
Predatory cycling index	2.97		%
Finn's Cycling index	10.70		%
Finn's mean path length	2.87		
Ascendency	27.7		%
Overhead	72.3		%
Capacity	72,152		flowbits

Discussion

The balanced model of the Gulf of Guinea ecosystem contains differences from the PICOLO model, as it is a more complex model than the original. This is a result of both changes to the model structure as functional groups and fleets within the model were of a finer scale as well as the model size. The PICOLO model was also built off data from the 1990s and the Gulf of Guinea model is built from data a decade later.

The maturity of the system *sensu* Odum, can be assessed using the primary production to respiration ratio. Ratios closer to one represent a mature system as the energy that is fixed by the system is balanced out by the cost of maintaining the system. In less developed ecosystems, the rate of primary production exceeds the rate of the respiration occurring in the system. In the case of the Gulf of Guinea model, the ratio is 3.18. While this value is greater than one, it is lower than other P/R values seen in open ocean systems. The ratio calculated for the Pacific Warm Pool model, where the largest purse-seine fishery in the world operates, was 5.6 (Griffiths, 2013). Less mature or developed ecosystems are more likely to be prone to ecological perturbations, including anthropogenic influences (Fetahi and Mengistou, 2007).

The gross efficiency (GE) of the fishery is quite low, at $1.03E-05$, as compared to other open ocean systems. The GE of the fishery in the PICOLO model was $1.10E-5$, slightly higher. The PICOLO modeled region is the most productive region of the eastern tropical Atlantic so it reasonable that the GE is higher for converting primary production into fisheries. The mean value of GE for published models using global data is 0.0002, making the GE for both models of the eastern tropical Atlantic an order of magnitude below the global average (Coll *et al.*, 2007).

The primary production required (PPR) to support the fisheries in the Gulf of Guinea model was 3.18%, slightly lower than the 4% in the earlier PICOLO model. PPR values have been calculated for a wide variety of marine systems, within tropical large marine ecosystems, the primary production required to sustain the fisheries was 9.21% and in the open sea, the value was 3.07%. Within temperate and higher latitude systems, the value was 5.89%. These values are quite low in contrast to upwelling zones with

values of 55.62% and 36.7% in the Mediterranean (Coll *et al.*, 2008a, 2006). The Gulf of Guinea does experience seasonal upwelling, however the fish production in terms of tuna catches in this region are low when compared to the central and western Pacific and eastern tropical Pacific tuna fishing grounds. The upwelling in the Gulf of Guinea at one point did support a healthy *Sardinella* fishery, however, this fishery collapsed in the 1970s and has yet to return (Bakun, 1996).

The average trophic level of the catch TL_c and the PPR can be taken together as an indicator of how a fishery can affect the surrounding ecosystem (Tudela *et al.*, 2005). For a particular value of PPR, a fishery with a higher TL of the catch could potentially be less disruptive than a lower mean TL of the catch. Similarly, for a given TL_c , a system with a lower PPR would be less likely to be overfished than a system with a higher PPR. The (TL_c) within the Gulf of Guinea was 4.68, a slight increase from the PICOLO model. From methods derived in the Tudela *et al.* study, similar low PPR values and high TL_c values as the Gulf of Guinea model depicted ecosystems that were not overexploited according to the ecosystem overfishing criteria (Gu nette, 2001, Okey and Pauly, 1993).

It must be noted that the ecosystem trends and indices calculated from the Ecopath modeling approach need to be viewed with care as several of the parameters used to build the model have low pedigree values. For instance, the highest values are assigned to studies conducted on the species or functional group in the modeled area. Lower values are assigned to estimates obtained from results of applying empirical equations, guesstimates and FishBase inputs. This modeling approach highlights the lack of information on the species in the Gulf of Guinea region and. The highest level of uncertainty in the model inputs is within the biomass estimates for several of the

functional groups. Biomass estimates for functional groups with fisheries associated with them, such as the yellowfin and skipjack groups, are much more robust than those of the groups that are found within the discards of the fishery. The species within these latter groups have never been formally assessed and it is difficult to properly estimate their biomass.

Varying the input parameters and determining the changes in the estimates derived by the model can determine the sensitivity of the Ecopath modeling approach to these input estimates. Monte Carlo simulations and time series calibration routines will be applied in Ecosim (Chapter 6) to further assess uncertainty and sensitivities. Ecopath models are more sensitive to inaccurate estimates of biomass and production to biomass ratios than other input parameters. The precision of the ecotrophic efficiencies obtained through Ecopath are in line with the input estimate precision (Essington, 2007). The choice to use biomass estimates for the discarded functional groups, Scombridae, Balistidae, Carangidae and Coryphaena, was due to the difficulties of reasonably estimating ecotrophic efficiencies for species not at the base or top of the food chain.

The fisheries within the region have the potential to change the ecosystem as a whole as well as the ecology of the species they target through the use of man-made FADs. There is some concern that seeding the ocean with man-made FADs can have detrimental ecological effects as natural floating objects, such as logs, can signify more productive masses of water in an otherwise unproductive open ocean region. It has been proposed that the placement of FADs in regions of the ocean without these productive water masses can cause tunas and other pelagic species to change their natural foraging behavior and change their residence times in regions with floating objects. The ecological

trap hypothesis describes this phenomenon and there is some evidence that areas with high densities of FADs can have detrimental impacts on the overall health of tunas (Dagorn *et al.*, 2010; Hallier and Gaertner, 2008b; Marsac *et al.*, n.d.; Taquet *et al.*, 2007).

The FADs present in the eastern Atlantic have the potential to either cause tunas to relocate to areas where they are not historically caught or increase the amount of time they spend in the area, as was seen in the Pacific (Dagorn *et al.*, in prep). Skipjack were 50% less likely to leave the area with the presence of an anchored FAD (Kleiber and Hampton, 1994). Changes in movement and residency time have the potential to alter the food web dynamics and diet matrix of the modeled area. The amount and type of prey consumed by predators within the system may thus be affected by the presence of drifting FADs. The number of empty stomachs of tuna caught under FADs was much greater (85%) than those of tuna caught without any associations with floating objects (25%) (Ménard *et al.*, 2000). The prey items that were present in stomachs of tunas caught on FADs were of lower weight than those of the prey items from free schooling tuna. Drifting FADs do not appear to have any trophic role for tunas as tunas are not feeding on the prey items that are associated with FADs (Hallier and Gaertner, 2008b). If FADs are placed in regions that are unsuitable for foraging, tunas can become entrained within such prey deserts. There is also increased competition for resources with the large amounts of biomass that aggregate around FADs, furthering the potential for changes to food web dynamics.

Conclusions

The Gulf of Guinea is an important, yet relatively understudied, region. It supports large-scale commercial fisheries and provides important breeding and nesting grounds for several ecologically sensitive species. This model highlights the lack of information available on the species found within the region and the important linkages between them. There is a large uncertainty about some of the data inputs, particularly biomass estimates, however, the robustness of this Ecopath model can be increased by using it as a base for an Ecosim model fitted to available time series for the area. Calibrated Ecosim models can also provide more informative indices about the ecosystem health of the region. Additionally, further analysis will also be conducted to test different scenarios about bycatch fate because the current model assumes that all bycatch caught by fleets are returned to the system as discards. One possible scenario will examine the changes that might occur if all bycatch is retained on board as opposed to discarded at sea. The full retention of bycatch has been proposed as a method to create incentives for fleets to avoid catching bycatch (Gilman, 2011).

Chapter 6 – Simulated ecological effects of the tuna purse seine fishery on the Gulf of Guinea

Overview

Fisheries targeting top predators can have far reaching ramifications for ecosystem structure and function, influencing species other than those directly fished. Additionally, the incidental capture of other species, or bycatch, can have wide-ranging effects due to predator-prey relationships and competition, and these influences are largely unknown (Cox *et al.*, 2002a; Criales-Hernandez *et al.*, 2006; Jennings and Kaiser, 1998; Daniel Pauly *et al.*, 1998; Zhou *et al.*, 2010). The tuna purse-seine fishery in the northern Gulf of Guinea is a relatively new fishery, beginning in the 1960's. Since 1991, it has expanded to include the use of man-made fish aggregating devices (FADs; Menard *et al.*, 2000; Torres-Irineo *et al.*, 2011). While catches of free schools (schools of tuna unassociated with other species or floating objects) of tuna still occur in the region, FAD catches have been increasing significantly (Fonteneau *et al.*, 2013). There is concern from both a fisheries management and conservation standpoint that this increased reliance on FADs can result in declines of other FAD-associated species that are incidentally caught as bycatch (Fonteneau *et al.*, 2013). This is especially problematic for similarly sized tunas that school together under FADs, regardless of the species, often resulting in large catches of juvenile bigeye tuna.

Efforts have been made to generally reduce the overall bycatch as well as to specifically decrease the amounts of juvenile bigeye tuna caught on FADs (Dagorn *et al.*, 2012; Moreno *et al.*, 2007a). At the most recent Commission meeting (2015), the International Commission on the Conservation of Atlantic Tunas (ICCAT) put into place

a series of recommendations aiming to both reduce the levels of FADs deployed in the eastern tropical ocean and to reduce total allowable levels of bigeye tuna catches (ICCAT Recommendation Doc. PA1-502E/2015).

Efforts to reduce bycatch in other fisheries have centered on banning discards, and forcing all catch, regardless of species, to be retained and landed. This creates incentives for boats to avoid capturing bycatch because space that could otherwise be occupied by more lucrative target species is instead taken up by less profitable bycatch (Gezelius, 2008; Gilman, 2011; Petter Johnsen and Eliassen, 2011). Additionally, balanced fishing practices are also being explored. In this fisheries management strategy, the aim is to harvest fish across trophic levels proportionally to their abundance in the ecosystem rather than just targeting selected taxa so as to avoid unforeseen trophic cascades (Garcia, 2010; Rochet and Benoît, 2012; Zhou *et al.*, 2010).

The Ecopath model of the Gulf of Guinea (Chapter 5) was employed as the basis of the development of an Ecosim model to assess the effects from the two different methods of purse-seine fishing: FAD and free sets. The model assumptions and predictions were tested by fitting available time series data to the functional groups within the model. Future Ecosim scenarios were then developed to simulate different possible future levels of fishing pressure and future differences in how functional groups from the bycatch are either retained or discarded by the purse-seine fleets.

Methods

Ecosim Approach

Ecosim is the time dynamic portion of the EwE package, which can be used to simulate ecosystem effects over time by simulating perturbations in fishing effort, fishing mortality and environmental forcing. The Ecosim portion of the software works by re-expressing the linear equations used to build the Ecopath model as differential equations, allowing the model to dynamically respond to changes in fishing pressure. The differential equations are set up similarly to Eq. 1 of the master equations from Ecopath and expressed as:

$$\frac{dB_i}{dt} = g_i \sum_j Q_{ij} + \sum_j Q_{ij} + I_i - (M_i + F_i + e_i)B_i$$

Equation 20

where dB/dt expresses the change in biomass over time, g_i is the net growth efficiency (production/consumption), M_i represents the non-predation mortality rate, F_i the fishing mortality rate, e_i as the emigration rate, I_i the immigration rate. The first summation estimates the total consumption by the group, while the second expresses the predation by all the predators on the group. The consumption rate term (Q) uses the “foraging arena” concept by which biomasses are dividing into two groups, vulnerable and invulnerable to predation (Christensen *et al.*, 2005).

The original Ecopath model of the Gulf of Guinea was parameterized using data from 2003-2013 (Chapter 5). Herein, the model was tuned using 21 time series data available for the region. To assess the reliability of model, it was re-parameterized using historic biomass levels to reflect the ecosystem conditions present in 1974 and Ecosim

was subsequently allowed to run until 2009. Both Ecopath and Ecosim are very sensitive to the initial diet matrix as these settings determine the starting predation mortality. For this reason, the same diet matrix was used in the reconstructed model from the 2003-2013 Gulf of Guinea model.

Biomass Levels

The Gulf of Guinea region is particularly data poor and it was necessary to make several assumptions about historic biomass levels. For species with stock assessments (billfish, skipjack, yellowfin and bigeye tuna) biomass levels for 1974 were obtained directly from stock assessments (Anonymous, 2014b, 2013, 2011a, 2011b, 2010b). For species with no stock assessment or associated fisheries, two methods were used to parameterize biomass: 1) biomass estimates were obtained from published literature; 2) biomass of historically unassessed functional groups were calculated from known, present-day biomass ratios applied to historically known stocks.

The biomass for small mesopelagics, cephalopods, and the plankton groups were estimated from historic trends (Schultz and Menard, 2003; Wiawe *et al.*, 2008) as were biomass estimates for sharks, rays, sea turtles and seabirds. For the major bycatch functional groups, Balistidae, Scombridae, Coryphaenidae, Carangidae and other epipelagic groups, it was assumed that most of the harvest on these functional groups came from the industrial purse seine fishery targeting skipjack. Therefore, the reconstructed populations of these groups were calculated from the relative change in biomass seen in skipjack.

The seabird functional group biomass was not adjusted for the reconstructed model as the major component of this group is *Puffinus gravis*, which has a large population size and has exhibited a stable population trend over time (Brown *et al.*, 1981). Shark and ray biomasses were increased for the reconstructed model as it is estimated that the major species within these functional groups have declined by as much as 80% in the last 20 years (Baum and Blanchard, 2010; Cortés *et al.*, 2010; Dulvy *et al.*, 2008). The biomass of marine mammals was not changed as the population of the species making up this functional group have largely remained stable. For example, the population of humpback whales off the west coast of Africa has increased by 4-5% in recent decades, and the population of sperm whales has become stable due to the decreased exploitation (Hazevoet and Wenzel., 2000, IWC 2015). Finally, the biomass of sea turtles was not changed as previous studies have shown that their population has remained relatively stable for the model region (Carranza *et al.*, 2006; Castroviejo *et al.*, 1994b; Gardner *et al.*, 2008).

Time Series

The original Ecopath model of the Gulf of Guinea was parameterized using data from 2003-2013. To test the model assumptions, the model was calibrated using 21 time series data available for the region, fishing mortality, catches and biomass of yellowfin, skipjack, bigeye tuna and billfish. Fishing mortality time series were necessary to drive the model. Albacore tuna time series were not used to tune the model, as their relative small total biomass rendered them numerically unimportant.

The billfish functional group comprises several species of billfish that have individual stock assessments. Catch levels of each species were obtained from the ICCATCATDIS database and were added together for each year occurring in the model area to give an overall catch time series for billfish. The estimates of fishing mortality for each species were obtained through stock assessments and correspondingly weighted to the proportion each species made up in the overall billfish functional group (Anonymous, 2013, 2011a, 2010a; Restrepo *et al.*, 2003). The average of the weighted fishing mortality was used to give an initial estimate of fishing mortality from 1974-2009. The fishing mortality was further modified to express the proportion of catches occurring in the model area relative to the entire Atlantic. From catch levels and fishing mortality values, the biomass in the model area for each year was found. Catches and biomass levels were expressed in $t/km^2/yr$.

Bigeye tuna and yellowfin tuna, both juvenile and adult, were tuned over the model duration using fishing mortality, absolute biomass and total catches. Total catches were obtained from the ICCATCATDIS database and the proportion of yellowfin tuna caught as juveniles to adults were calculated from available catch at age frequencies from 1974 to 2013. Fishing mortality at age was obtained through stock assessments and the relative fishing pressure in the model area was applied to the fishing mortality (Anonymous, 2011c, 2009).

The skipjack tuna catch data was scaled to the model area. Relative fishing mortality for skipjack in the Gulf of Guinea was found through catches from the region relative to total catches for eastern Atlantic stock. The biomass time series was obtained through historical biomass estimates in the most recent stock assessment (Anonymous, 2014b).

The vulnerabilities of the functional groups were iteratively adjusted to fit the simulated time patterns to the observed time series. These vulnerabilities adjust the level to which prey are vulnerable to each predator in the diet composition matrix through the consumption rate (C) of type i biomass by type j functional groups in Equation 2 (Pauly *et al.*, 2000)

$$C_{ij} = v_{ij}a_{ij}B_iB_j/(v_{ij} + v'_{ij} + a_{ij}B_j)$$

Equation 21

In this equation, a_{ij} is the effective search rate of predators j for prey i and v_{ij} is the behavioral exchange between vulnerable states and invulnerable states v'_{ij} . B_i and B_j are the biomass of the prey functional group and the predator functional group.

The vulnerabilities of all functional groups were iteratively adjusted by 1%. A second fitting routine was applied to only the functional groups with time series associated to them. Goodness-of-fits measurements were assessed using sum of squared deviations (SS) of the biomasses and catches from the predicted biomasses and catches as well as the Akaike information criterion (AIC) (Christensen, 2004; Coll *et al.*, 2009). Vulnerabilities to predation were capped at 100 if these values were set above 100 as a result of the fitting to time series routine (Christensen *et al.*, 2009).

Scenarios

To assess shifts in the ecosystem resulting from changes in fishing pressure and bycatch harvest, two base models were developed using the same input data as the model used to fit the time series. The vulnerabilities of functional groups to predation obtained from the fitting process were fixed and the simulation model start year was set at 2009. The simulation ended in 2059. The only difference between the two base models was in how bycatch were treated. In the discard model, bycatch were discarded into two detritus groups, FAD purse seine discards and free purse seine discards. The initial amounts and composition of the bycatch going into the two discard groups was set from the observed bycatch values for the two respective fishing modes of purse seine vessels (Chapter 2 and 5). In the retained bycatch model, the bycatch from the two purse seine fleets was exported from the system and not sent back into the detritus pool to be recycled by the system. From these two base models, five scenarios were run under the two different treatments of bycatch fate.

An initial scenario was used to establish a baseline for any changes observed for models, discard and the retention model. Changes to the system were forced by linearly adjusting the effort data of the two purse seine fleets. For the baseline scenario, fishing effort for both the free and FAD fisheries were kept constant. Scenario 1 represented an increased fishing effort for both fleets by 50% by 2059 while scenario 2 simulated constant free purse seine fleet effort and an increase of the FAD purse seine fleet by 50%. Scenario 3 parameters held FAD purse seine effort constant and increased the free purse seine fleet by 50%. Scenarios 4 and 5 represented a reduction in fishing effort; while scenario 4 represented a decrease in both FAD and free purse seine effort by 25% and

scenario 5 held the free purse seine fleet constant and reduced the FAD purse seine fleet effort by 25%. The scenarios run under the discard model are henceforth denoted as: D1, D2, D3, D4 and D5. The scenarios run under the retention model are herein referred to as R1, R2, R3, R4 and R5.

Ecological Indicators

Ecopath and Ecosim provide several methods to assess the state of the ecosystem in response to fishing. In addition to changes in biomass of functional groups, these indicators were used to measure changes to the structure of the ecosystem resulting from the different future scenarios considered.

The Fishing In Balance (FIB) index offers an indication of ecosystem degradation resulting from fisheries, using the mean trophic level of the catch, the total catch and the transfer efficiency between trophic levels at the start and end of the time series (Coll *et al.*, 2008a; Griffiths, 2013; Pauly *et al.*, 2000).

$$FIB = \log \left(Y_i \cdot \left(\frac{1}{TE} \right)^{TL_i} \right) - \log \left(Y_0 \cdot \left(\frac{1}{TE} \right)^{TL_0} \right)$$

Equation 22

Y_i and Y_0 are the catch at the end and the beginning of the time series respectively, TE the transfer efficiency between trophic levels and TL_i and TL_0 are the mean trophic levels of the catch of the end and beginning of the time series. A decrease in the index over time signifies overfishing while an increase could potentially indicate an expansion of the fishery (Fulton *et al.*, 2005; S. M. Garcia *et al.*, 2003).

The average trophic level of catch (TL_c) is also a valuable indicator used to determine if fishery practices are changing or expanding within the model region. The classic use of this measurement is to assess if “fishing down food webs” (Pauly, 1998), the targeting of lower trophic level species in response to a decline in target, higher trophic level species.

$$TL_{cy} = \frac{\sum_i (TL_i \cdot Y_{iy})}{\sum_i Y_{iy}}$$

Equation 23

The trophic level of the catch for a given year (TL_{cy}) is equal to the sum of the TL of group i and the yield of group i in the given year (Y_{iy}).

Kempton’s Q index measures the biomass of functional groups above TL 3 by defining the slope of the cumulative log-abundance curve of the functional groups (Griffiths, 2013). This method applies the theory behind field sampling individual animals to assess changes of biodiversity over time. Increases in the index represent an increase in upper level biomass diversity (Ainsworth and Pitcher, 2006).

$$Q = \frac{0.8 \cdot S}{\log \left(\frac{R_2}{R_1} \right)}$$

Equation 24

where S is the total number of functional groups in the model and R_2 and R_1 are the 10th and 90th percentiles of the biomass values in the abundance distribution of the model (Ainsworth and Pitcher, 2006; Griffiths, 2013).

Other indicators examined include total system throughput (TST), which provides an indirect measure of the size of ecosystem through the sum of flows quantified by consumption, production, respiration, exports, imports and flows to detritus measured in $\text{t km}^{-2} \text{ yr}^{-1}$ (Coll *et al.*, 2009). Nutrient recycling indices were measured with Finn's cycling index (FCI) and the predatory cycling index (PCI). FCI measures flows within the ecosystem that are recycled while PCI corresponds to the FCI but calculates fraction of recycled throughput with detritus groups removed from the calculations (Allesina and Ulanowicz, 2004; Christensen and Walters, 2004). Path length was also measured, which represents the average number of groups a unit of nutrient passes through upon entering the system before exiting (Libralato *et al.*, 2002). The ascendancy of the system was assessed in the different models and scenarios. Ascendancy is based on information theory and is a function of the trophic networks. It is found through a combination of the total system throughput and the organization of the flow structure within the ecosystem (Patrício *et al.*, 2006; Ulanowicz, 1980). In practical terms, an increase in the ascendancy of the ecosystem is indicative of degradation. The capacity of the ecosystem represents the potential of the ecosystem to expand. The overhead of the system, which indicates inefficiencies and redundant degrees of freedom within the system, was measured through its different components (Morissette *et al.*, 2010) and it represents the amount that capacity exceeds the ascendancy of the ecosystem. The overhead is the limit on the ecosystem's ability to expand (Ulanowicz, 1986).

Results

The reconstructed model was balanced with slight adjustments to biomass levels of some of the bycatch species as well as changes in the total mortality of skipjack, billfish, yellowtail and bigeye tunas to reflect the lower fishing pressure present in 1974.

Table 43. Final model fits of all functional group's vulnerabilities adjusted and only the groups with time series (TS) adjusted.

Model	Starting SS	Parameters	Number AIC data pts.	AIC	Ending SS
Groups with TS	182.02	6	42	215.0	125.7
All groups	182.02	25	42	247.9	111.2

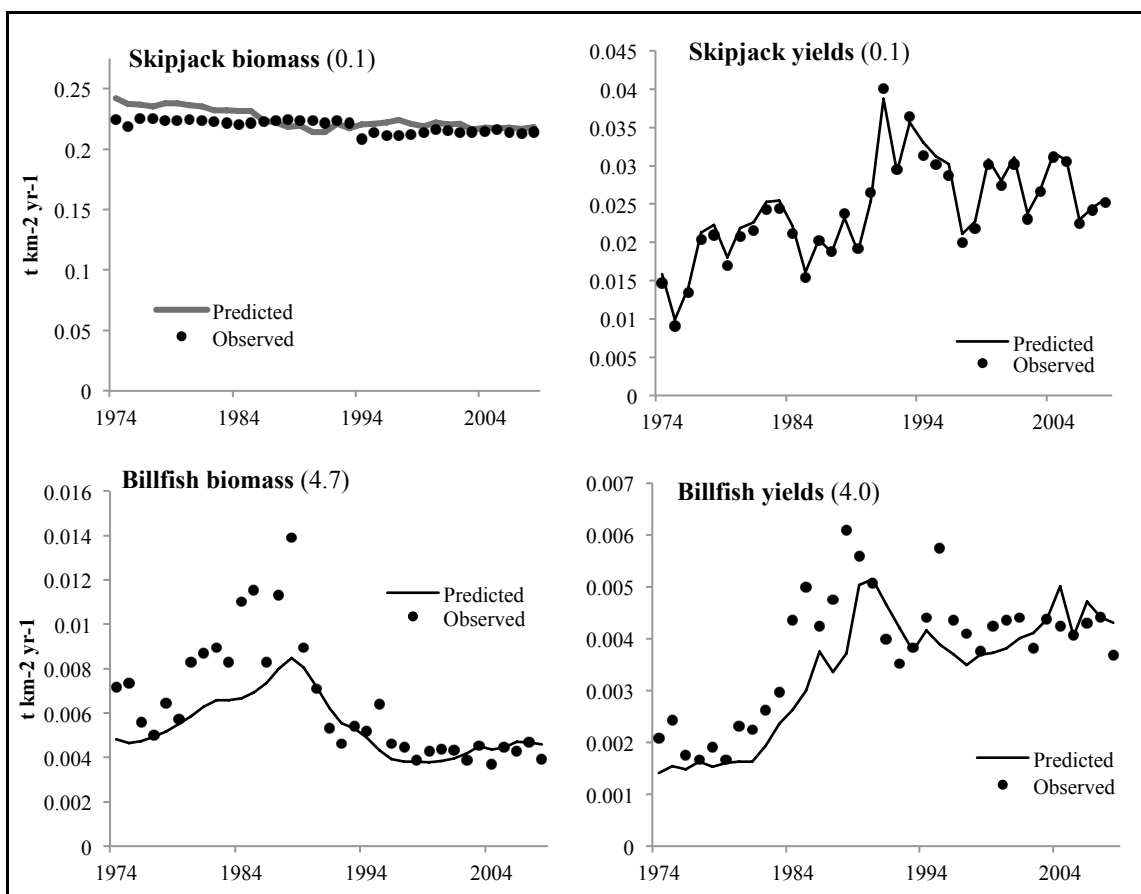

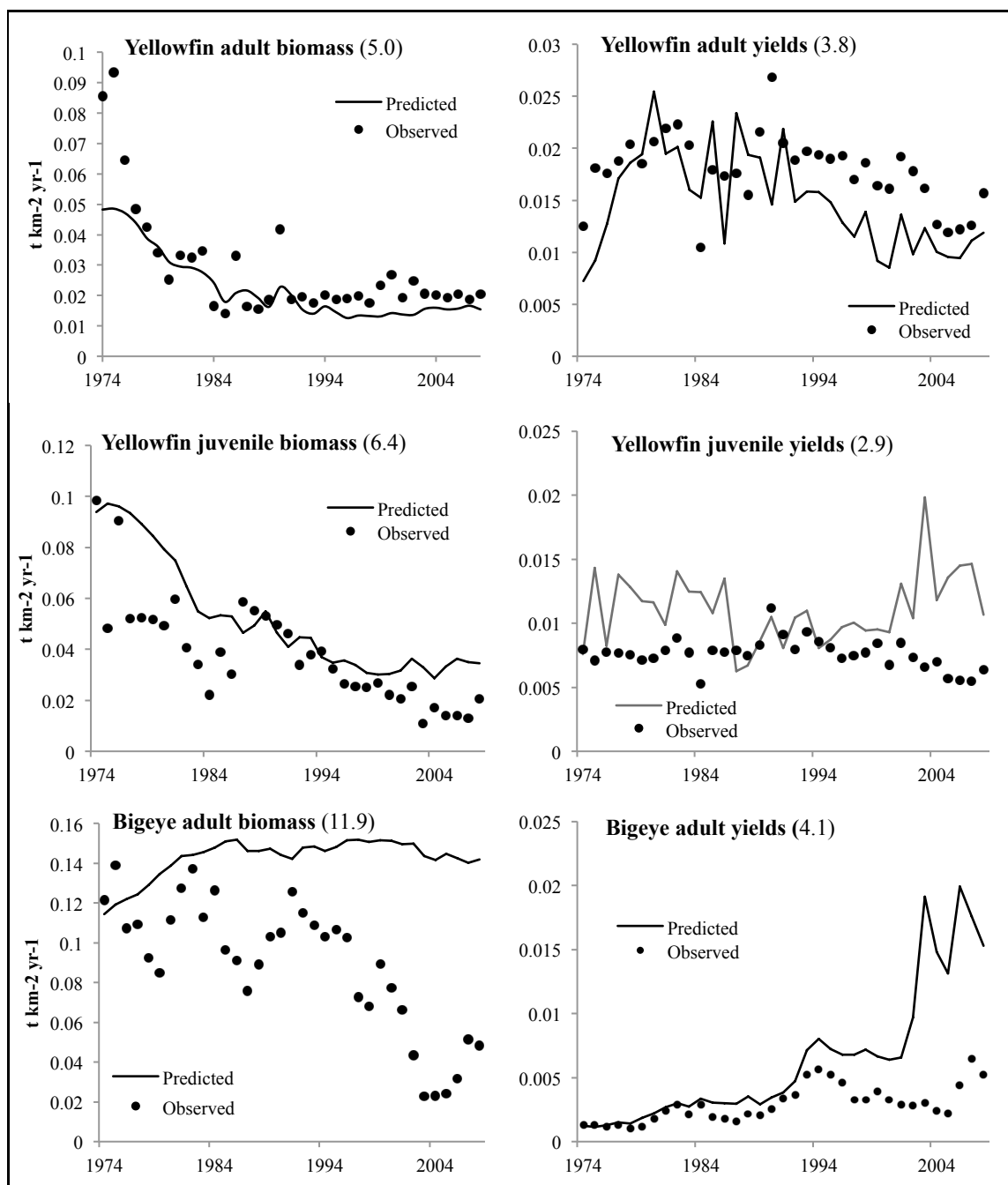

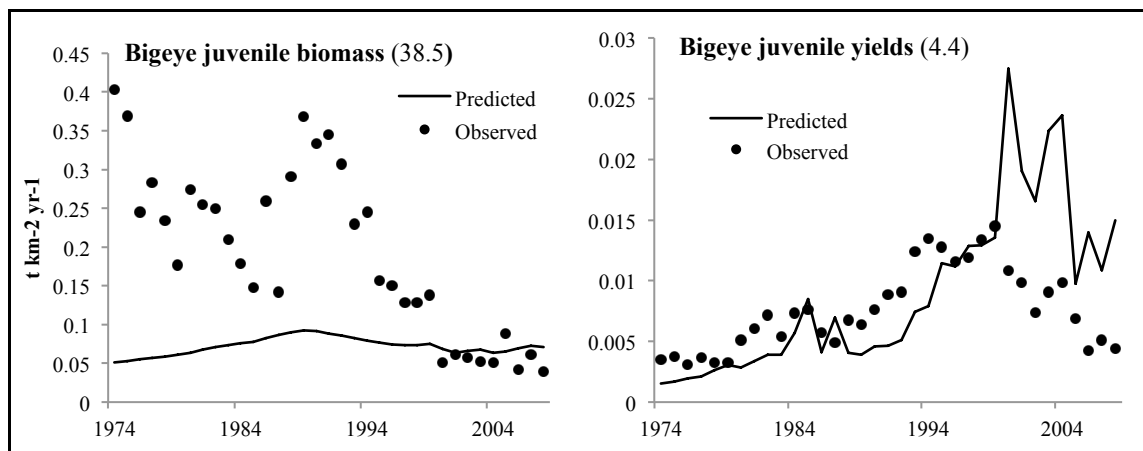

Figure 45. Model outputs fitted to time series data. Value within parentheses are the sum of squares. Time series run from 1974-2009.

The best fits of the model to the observed time series patterns were skipjack catches (SS = 0.046) and skipjack biomass (SS = 0.66). The poorest fits of the observed time series patterns to the simulated model outputs were seen with bigeye tuna adult biomass and bigeye tuna juvenile biomass. Juvenile biomass model estimates converged towards the most recent values of observed biomass while the beginning of the simulated model outputs was a very poor fit. The yellowfin time series had reasonable fits according to the sum of squares, however the juvenile yellowfin tuna catches from the simulated outputs contained jagged shifts that were not observed in the reported catches. Billfish catches and biomass had reasonable fits, except in the middle of the time series around the 1990s. While the AIC was lower for the model that only adjusted the vulnerabilities for groups with time series, a smaller SS and better visual fits were achieved allowing all vulnerabilities of functional groups to be adjusted.

There were clear shifts in the patterns observed across three measured indicators starting in 1991, which corresponds to an increase and an expansion in the purse seine fishing effort in the Gulf of Guinea (Menard *et al.*, 2000). The FIB index increased after

1991 with more extreme peaks and troughs while the TL of the catch flattened out and began to decline. The Kempton's Q index exhibited large fluctuations after 1991 compared to the prior period (Figure 2).

Scenarios: Biomass and Yield

The patterns of biomass changes in functional groups in the five scenarios were the same for the two models, discarded and retained bycatch (Table 45). Bycatch changes between the fished functional groups and the functional groups caught as bycatch are shown for the discarded bycatch model (Figure 46). The biomass changes were the same for both the discarded bycatch model and the retained bycatch model, for parsimony, only the discarded bycatch model results are presented.

Baseline

The baseline scenario kept fishing effort fixed through time. There were changes in biomass across five functional groups, the largest observed in the epipelagic group II (-16%). Billfish decreased by 3%, followed by Coryphaenidae and Balistidae groups (-1%). There was a slight increase in yield of skipjack and sharks in the baseline scenario (<1% and 6%).

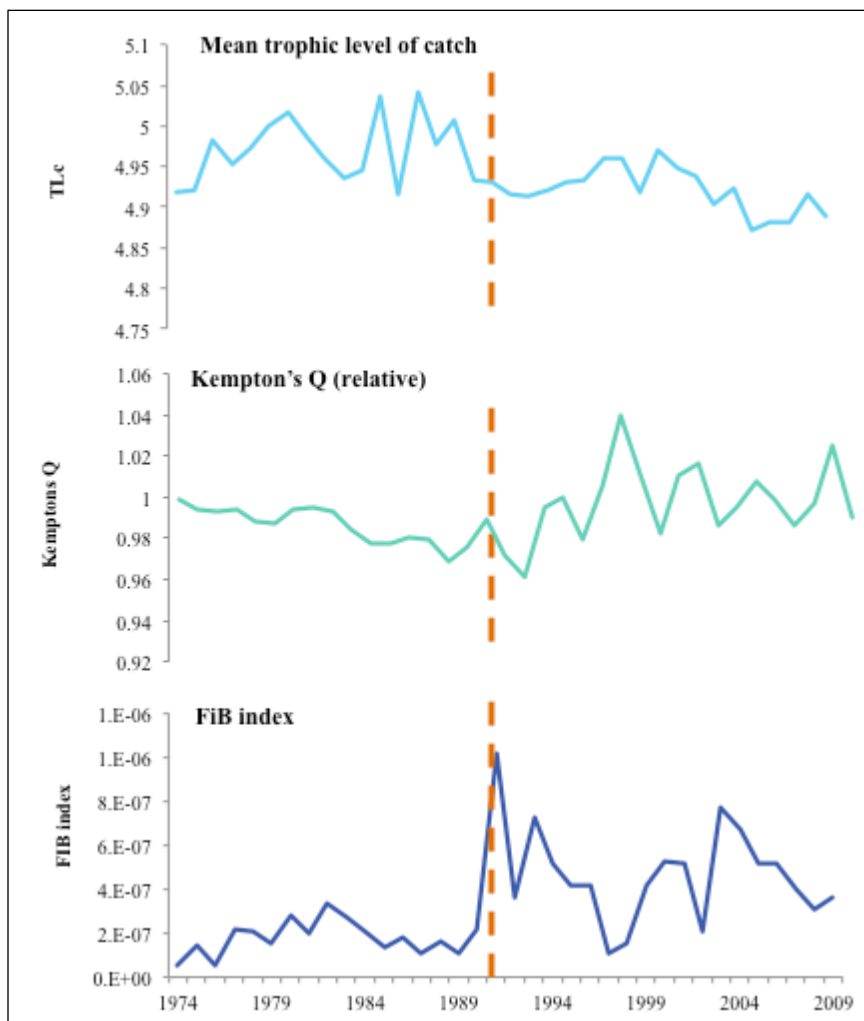

Figure 46. Annual estimates of three ecosystem indicators from 1974-2009. Dashed line at 1991.

Scenario 1

This scenario linearly increased fishing effort by 50% for both the FAD and free purse seine fleets from 2009 to 2059. The largest increase in biomass was seen within Scombridae (49%), followed by sharks (36%). The largest decrease in biomass was observed in the epipelagic I group (-65%). The main target group of the purse seine fleets, skipjack, decreased by 4%, while bigeye tuna juveniles showed no change and yellowfin tuna juveniles increased by 2%.

The yield of skipjack increased by 35%, yellowfin adult by 55%, yellowfin tuna juvenile by 44%, bigeye tuna adult by 9% and the yellowfin tuna juvenile by 36%. The yield of the functional groups caught as bycatch also increased in this scenario. The largest increases were the Scombridae group (122%) and Coryphaenidae (52%) (Table 44).

Scenario 2

This scenario linearly increased fishing effort of the FAD purse seine fleet by 50% and held free purse seine fishing effort constant from the first year. The largest increase in biomass for this scenario was observed in the Scombridae functional group (7%) followed by sharks (3%). The largest decrease in biomass was observed in the epipelagic I group (-16%) followed by bigeye adult and juvenile functional groups (-5%).

Increases in yield were observed in skipjack, yellowfin juvenile and bigeye juvenile functional groups while a decrease was seen in the yellowfin adult tuna group. Increases in yield for all the bycatch species increased for this scenario, with the exception of epipelagic I (-62%).

Scenario 3

The effort directed to free schools by the purse seine fleet was increased linearly by 50% while the effort directed to FAD associated schools was held constant from 2009. The largest increase in biomass was seen in sharks (39%), bigeye tuna adults (9%) and scombridae (40%). The largest decreases in biomass were observed in epipelagic I (-64%) and billfish (-5%) functional groups.

Skipjack yields did not greatly increase under this scenario (6%) while the largest increases in yield was observed in adult yellowfin tuna (52%) and juvenile yellowfin tuna (22%). Bycatch group yields increased for sharks (41%) and Scombridae (47%) and decreased in epipelagic I (-18%).

Scenario 4

The purse seine fleet fishing effort directed to FAD associated and free schools in scenario 4 were linearly decreased by 25% by 2059. Biomass increased the most for epipelagic I group (9%). The largest decrease was observed in Scombridae (-23%). Yields decreased for all the target groups, with the largest decreases seen in yellowfin tuna adult (-27%) and juveniles (-22%).

Scenario 5

This scenario decreased FAD fishing effort by 25% and held fishing effort for free purse seine fleets constant. Shark biomass increased by 8% while epipelagic I functional group decreased by 16%. Yields decreased for all the groups with the exception of bigeye adult, which increased by 2%. Bycatch yields decreased with the exception of sharks (7%).

Scenarios: Ecological Indicators

All measured system statistics examining flows and ecosystem indicators are listed in Table 46. Trends in ecosystem indicators relative to the baseline values were compared across models and scenarios (Table 47). Trends that are indicative of ecosystem degradation were observed : increases in system throughput (scenarios D1, D2, D3 and R1), decreases in Finn's Cycling Index (FCI) (scenarios D4, D5 and R4),

decreases in path length (scenarios D1, D2, D3), increases in export (scenarios D1, D2 and D3), increases in respiration (scenarios D1, D2, D3, R1, R2 and R3), increases in production (scenarios D4, D5, R4 and R5), increases in catch (scenarios D1, D2, D3, R1, R2 and R3), increased proportion of flow to detritus (scenarios D1, D2, and D3), increases in ascendancy (scenarios D4, D5, R4 and R5), reduction in mean TL of catch (scenarios D1, D2, R1 and R2) and a decrease in Kempton's Q (scenarios D1, D3, D5, R1, R3 and R5) (Christensen *et al.*, 2005; Forrester *et al.*, 2012; Fulton *et al.*, 2005).

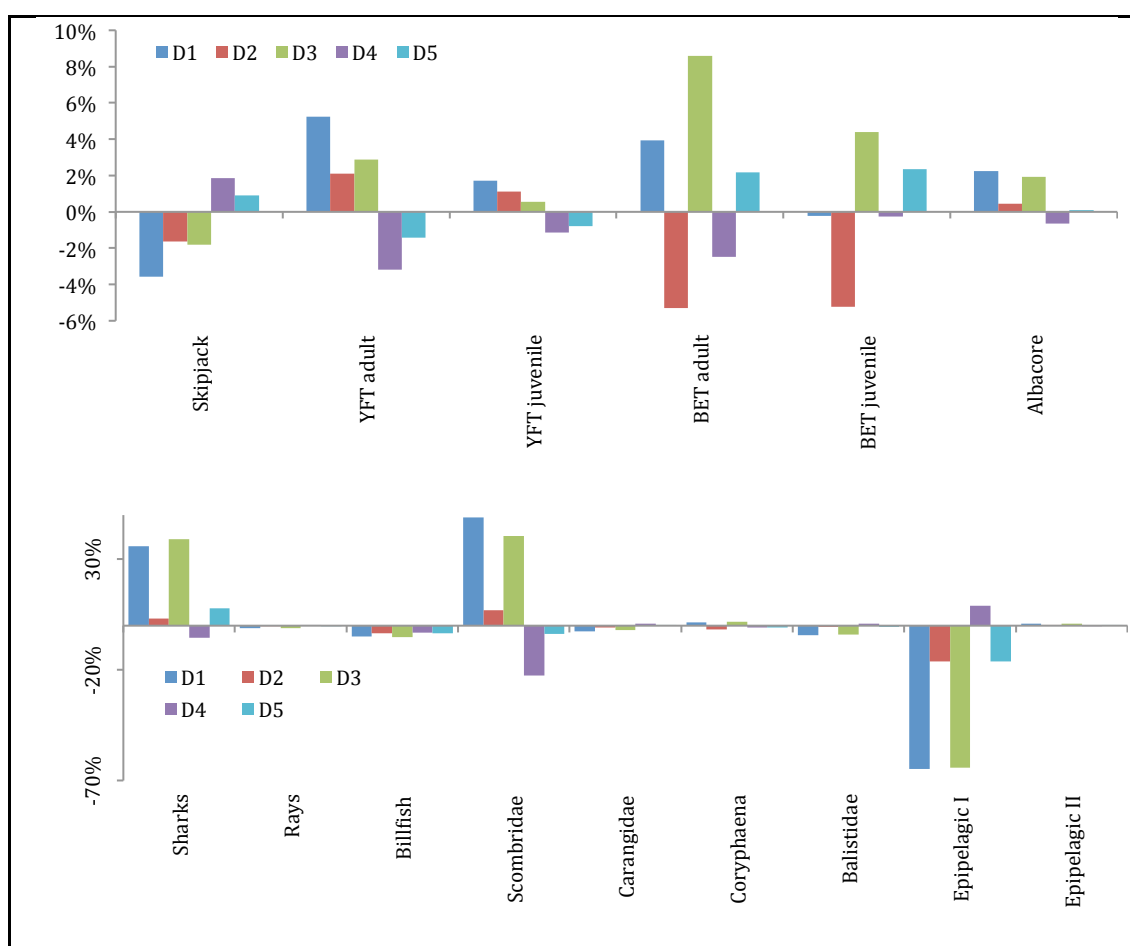

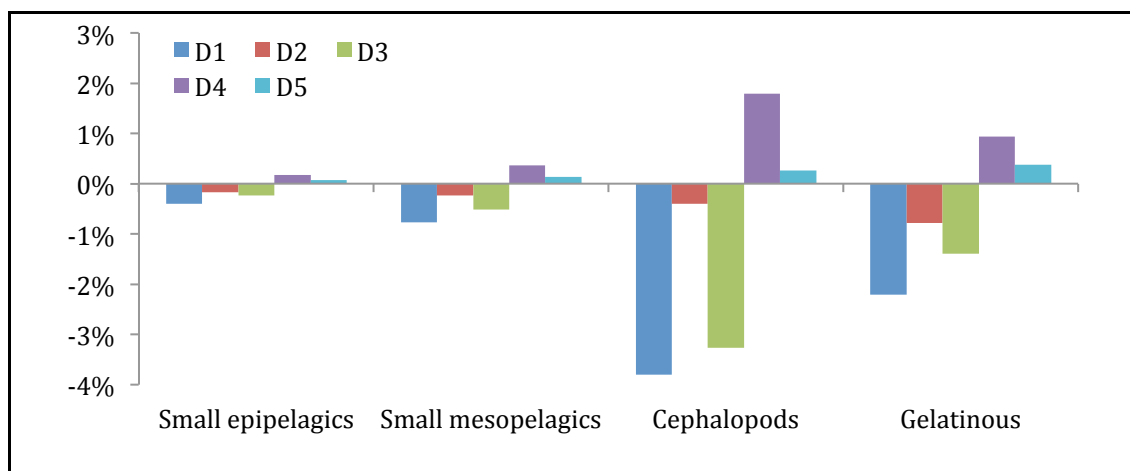

Figure 47. Percent changes in biomass across the five scenarios for discarded bycatch model (results same for retained bycatch model). Top panel shows functional groups targeted by free and FAD purse seine fleets, middle panel shows groups caught as bycatch and bottom panel shows biomass changes in lower trophic level forage fish. D1-D5 represent different discard scenarios.

Table 44. Changes (%) to yield (t/km²/yr) for target groups and bycatch groups. Groups shaded for changes above 4%. D1-D5 represent different discard scenarios.

TARGET SPP.	Baseline	D1	D2	D3	D4	D5
Skipjack	0.08	34.69	30.13	5.54	-18.61	-15.53
YFT adult	-0.27	54.99	2.10	51.51	-26.41	-1.43
YFT juvenile	-0.16	43.75	21.57	21.92	-21.83	-10.87
BET adult	-0.25	9.11	-5.27	13.97	-4.91	2.16
BET juvenile	-0.12	35.69	24.21	9.63	-18.42	-13.69
BYCATCH SPP.	Baseline	D1	D2	D3	D4	D5
Sharks	6.28	39.56	4.48	40.95	-6.63	7.15
Billfish	-3.42	14.36	11.15	-0.29	-12.90	-10.75
Scombridae	-0.16	122.34	55.14	46.95	-41.96	-25.72
Carangidae	-0.16	45.65	43.82	2.58	-24.45	-22.70
Coryphaena	-1.06	51.60	42.72	6.57	-25.67	-23.44
Balistidae	-0.56	43.27	47.17	-2.72	-24.42	-24.81
Epipelagic I	-34.76	20.55	-62.04	-18.39	-34.76	-18.39

Table 45. Percent change in biomass of functional groups from 2009-2059 for the two models (discarded or retained bycatch) and 5 scenarios. Scenarios D4, D5, R4, R5 represent a reduction in purse seine catches. Changes are shaded (blue: +; orange: -).

	Baseline	D1	D2	D3	D4	D5	Baseline	R1	R2	R3	R4	R5
Seabirds	0%	-2%	0%	-2%	1%	0%	0%	-2%	0%	-2%	1%	0%
Sharks	6%	36%	3%	39%	-5%	8%	6%	36%	3%	39%	-5%	8%
Marine mammals	0%	0%	0%	0%	0%	0%	0%	0%	0%	0%	0%	0%
Rays	0%	-1%	0%	-1%	0%	0%	0%	-1%	0%	-1%	0%	0%
Sea turtles	0%	-2%	-1%	-1%	1%	0%	0%	-2%	-1%	-1%	1%	0%
Billfish	-3%	-5%	-3%	-5%	-3%	-3%	-3%	-5%	-3%	-5%	-3%	-3%
Skipjack	0%	-4%	-2%	-2%	2%	1%	0%	-4%	-2%	-2%	2%	1%
YFT adult	0%	5%	2%	3%	-3%	-1%	0%	5%	2%	3%	-3%	-1%
YFT juvenile	0%	2%	1%	1%	-1%	-1%	0%	2%	1%	1%	-1%	-1%
BET adult	0%	4%	-5%	9%	-2%	2%	0%	4%	-5%	9%	-2%	2%
BET juvenile	0%	0%	-5%	4%	0%	2%	0%	0%	-5%	4%	0%	2%
Albacore	0%	2%	0%	2%	-1%	0%	0%	2%	0%	2%	-1%	0%
Scombridae	0%	49%	7%	40%	-23%	-4%	0%	49%	7%	40%	-23%	-4%
Carangidae	0%	-3%	-1%	-2%	1%	0%	0%	-3%	-1%	-2%	1%	0%
Coryphaena	-1%	1%	-2%	2%	-1%	-1%	-1%	1%	-2%	2%	-1%	-1%
Balistidae	-1%	-4%	-1%	-4%	1%	-1%	-1%	-4%	-1%	-4%	1%	-1%
Epipelagic I	-16%	-65%	-16%	-64%	9%	-16%	-16%	-65%	-16%	-64%	9%	-16%
Epipelagic II	0%	1%	0%	1%	0%	0%	0%	1%	0%	1%	0%	0%
Sm. epipelagics	0%	0%	0%	0%	0%	0%	0%	0%	0%	0%	0%	0%
Sm. mesopelagics	0%	-1%	0%	-1%	0%	0%	0%	-1%	0%	-1%	0%	0%
Cephalopods	0%	-4%	0%	-3%	2%	0%	0%	-4%	0%	-3%	2%	0%
Gelatinous	0%	-2%	-1%	-1%	1%	0%	0%	-2%	-1%	-1%	1%	0%
Macrozooplankton	0%	0%	0%	0%	0%	0%	0%	0%	0%	0%	0%	0%
Mesozooplankton	0%	0%	0%	0%	0%	0%	0%	0%	0%	0%	0%	0%
Microzooplankton	0%	0%	0%	0%	0%	0%	0%	0%	0%	0%	0%	0%
Phytoplankton	0%	0%	0%	0%	0%	0%	0%	0%	0%	0%	0%	0%
Free PS discards	0%	66%	-1%	66%	-29%	0%	-100%	-100%	-100%	-100%	-100%	-100%
FAD PS discards	0%	59%	49%	6%	-28%	-25%	-100%	-100%	-100%	-100%	-100%	-100%
Detritus	0%	0%	0%	0%	0%	0%	0%	0%	0%	0%	0%	0%

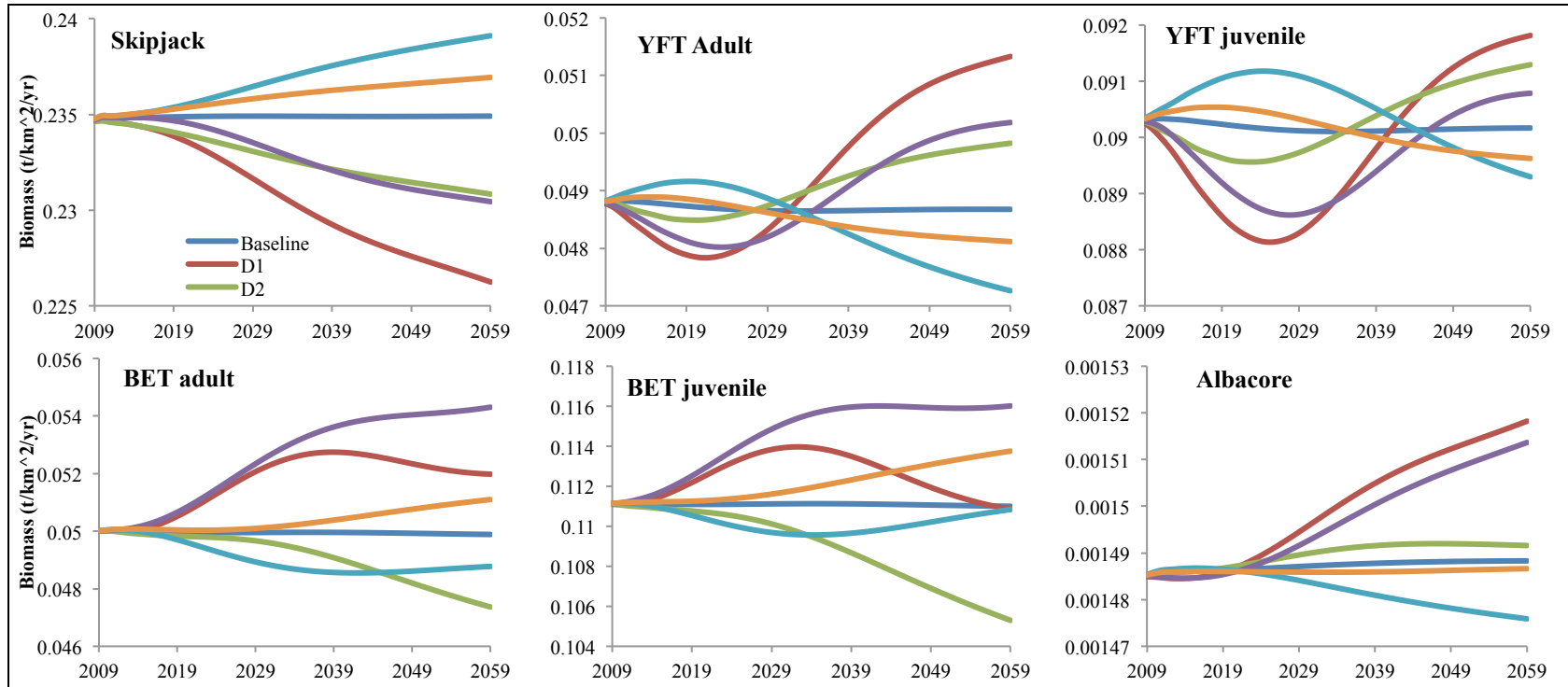

Figure 48. Biomass changes in t/km²/yr for targeted tuna species. Baseline has constant fishing pressure, D1: 50% increase in both FAD and free school fishing pressure, D2: 50% increase in FAD fishing pressure, no change in free, D3: no change in FAD, 50% increase in free school fishing pressure, D4: 25% reduction in both FAD and free school, D5: 25% decrease in FAD fishing pressure, free school pressure remained constant. Models run under discarded bycatch model, patterns in biomass changes same in retained bycatch model.

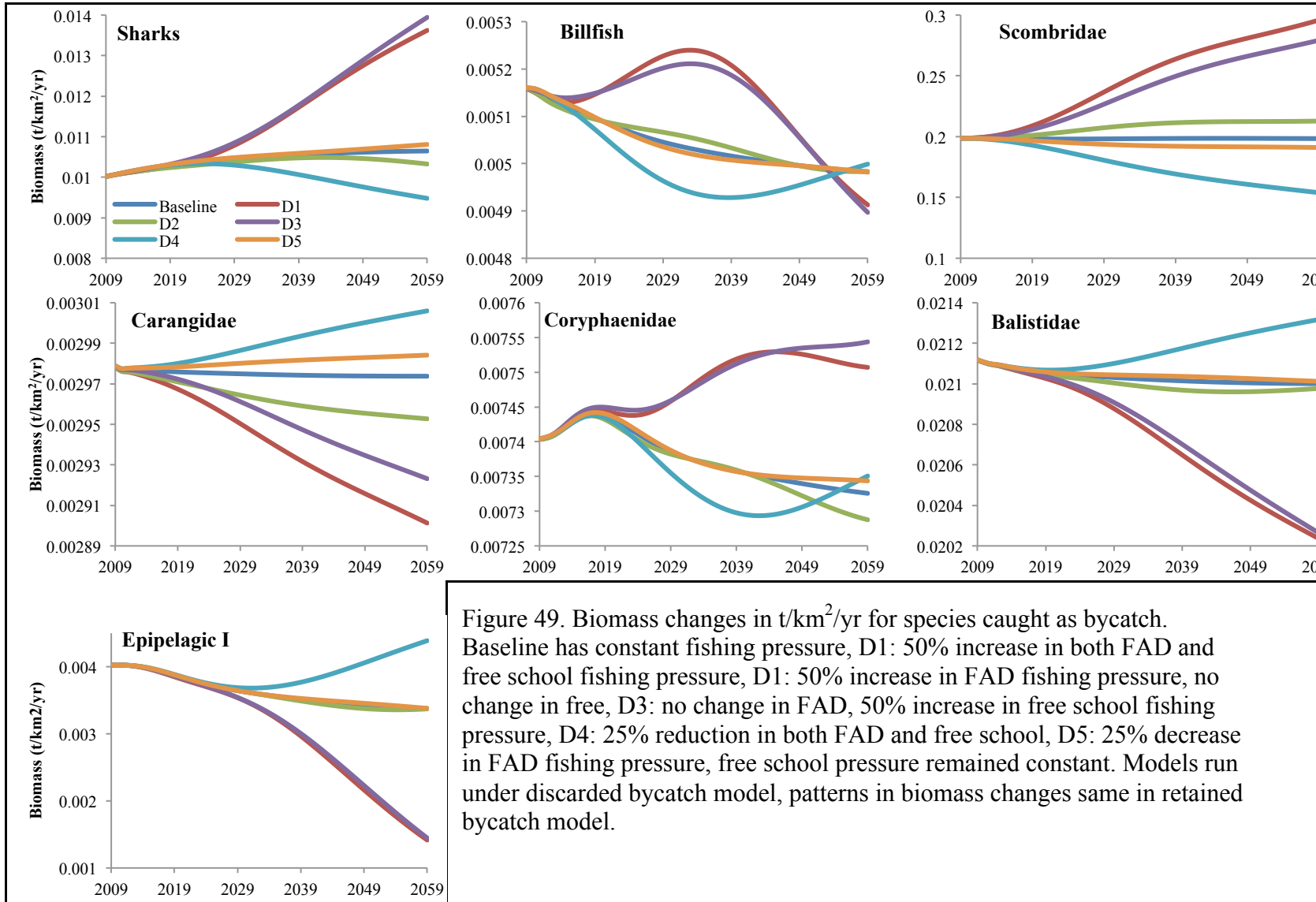

Figure 49. Biomass changes in $t/km^2/yr$ for species caught as bycatch. Baseline has constant fishing pressure, D1: 50% increase in both FAD and free school fishing pressure, D2: 50% increase in FAD fishing pressure, no change in free, D3: no change in FAD, 50% increase in free school fishing pressure, D4: 25% reduction in both FAD and free school, D5: 25% decrease in FAD fishing pressure, free school pressure remained constant. Models run under discarded bycatch model, patterns in biomass changes same in retained bycatch model.

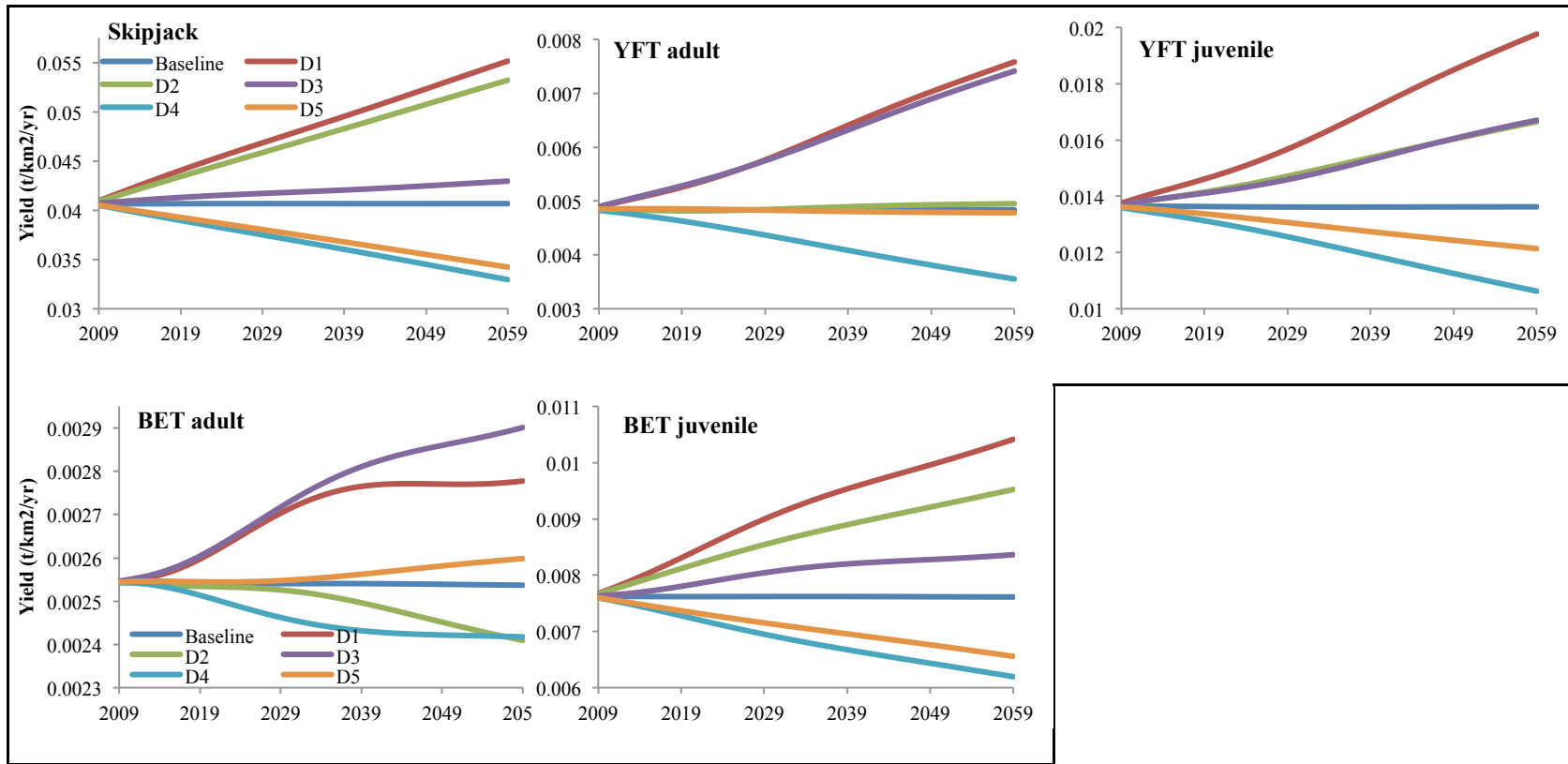

Figure 50. Yield changes in t/km²/yr for target species in all 5 scenarios. Baseline has constant fishing pressure, D1: 50% increase in both FAD and free school fishing pressure, D2: 50% increase in FAD fishing pressure, no change in free, D3: no change in FAD, 50% increase in free school fishing pressure, D4: 25% reduction in both FAD and free school, D5: 25% decrease in FAD fishing pressure, free school pressure remained constant.

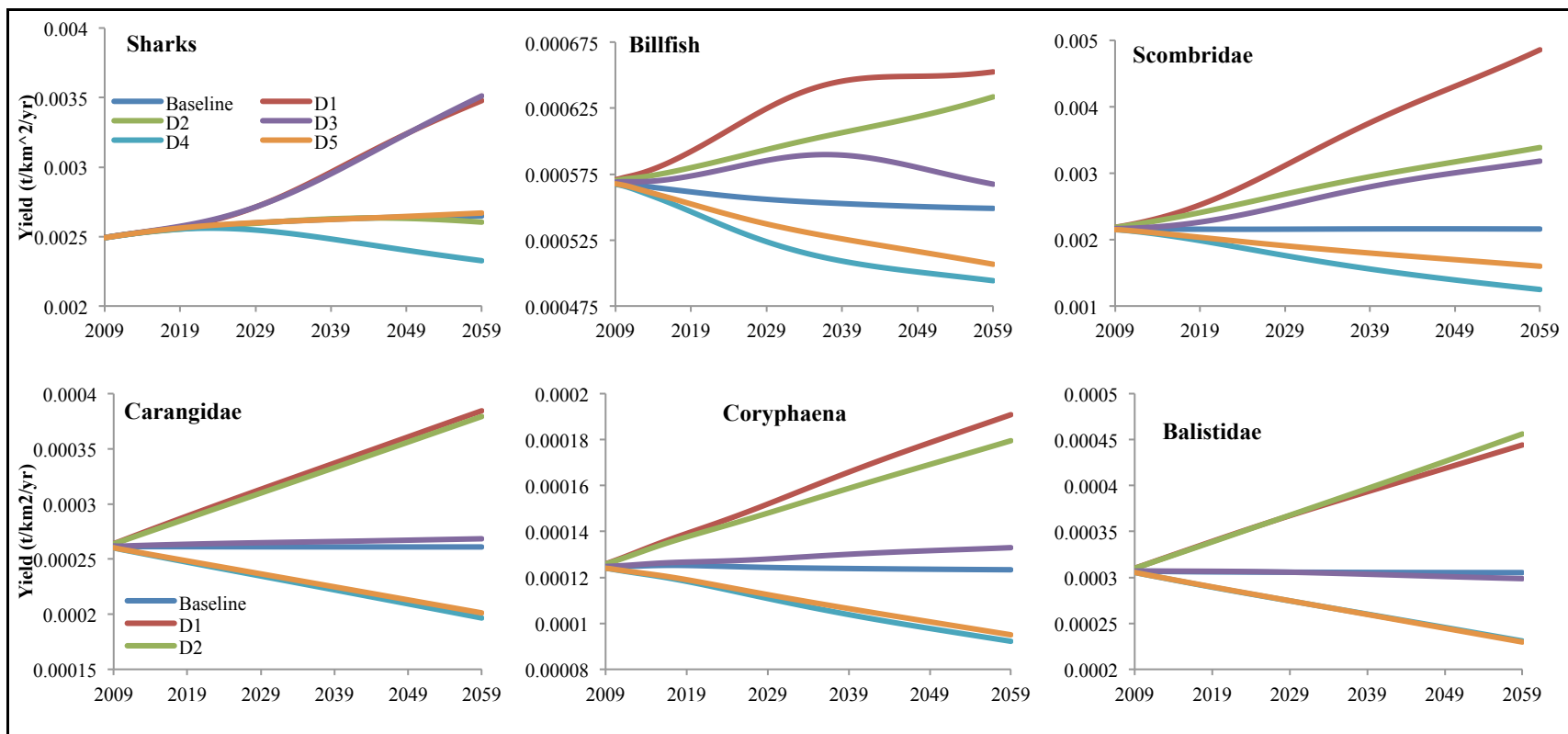

Figure 51. Yield changes in t/km²/yr for bycatch species in all 5 scenarios. Baseline has constant fishing pressure, D1: 50% increase in both FAD and free school fishing pressure, D2: 50% increase in FAD fishing pressure, no change in free, D3: no change in FAD, 50% increase in free school fishing pressure, D4: 25% reduction in both FAD and free school, D5: 25% decrease in FAD fishing pressure, free school pressure remained constant

Table 46. All measured system statistics for all scenarios and models at the completion of the simulation (Year 2059). D1-D5 represent different discard scenarios R1-R5 represent different bycatch retention scenarios.

	Baseline	D1	D2	D3	D4	D5	R1	R2	R3	R4	R5
Throughput	21,316	21,319	21,317	21,318	21,315	21,316	21,317	21,315	21,316	21,313	21,314
PCI	2.31	2.29	2.30	2.30	2.31	2.31	2.29	2.30	2.30	2.31	2.31
FCI	20.00	20.00	20.00	20.00	19.99	20.00	20.01	20.00	20.00	20.00	20.00
Path length	4.43	4.43	4.43	4.43	4.43	4.43	4.43	4.43	4.43	4.43	4.43
Export	12.10	12.13	12.12	12.11	12.08	12.09	10.13	10.11	10.11	10.08	10.08
Resp	4,799	4,800	4,799	4,800	4,798	4,799	4,800	4,799	4,800	4,798	4,799
Prim prod	8,766	8,757	8,763	8,761	8,770	8,768	8,757	8,763	8,761	8,770	8,768
Prod	11,517	11,508	11,514	11,511	11,520	11,518	11,508	11,514	11,511	11,520	11,518
Biomass	112.25	111.97	112.14	112.08	112.38	112.30	111.96	112.14	112.08	112.38	112.30
Catch	0.08	0.11	0.10	0.09	0.06	0.07	0.11	0.10	0.09	0.06	0.07
Prop flow det	0.33	0.33	0.33	0.33	0.33	0.33	0.33	0.33	0.33	0.33	0.33
Ascendency	15,812	15,810	15,811	15,811	15,813	15,813	15,810	15,811	15,811	15,813	15,813
Capacity	74,649	74,593	74,628	74,615	74,673	74,660	74,569	74,604	74,592	74,649	74,636
A/C	0.2118	0.2120	0.2119	0.2119	0.2118	0.2118	0.2120	0.2119	0.2120	0.2118	0.2119
Entropy	3.50	3.50	3.50	3.50	3.50	3.50	3.50	3.50	3.50	3.50	3.50
TLc	4.74	4.73	4.72	4.75	4.75	4.76	4.73	4.72	4.75	4.75	4.76
Kemptions Q (relative)	0.99	0.98	1.00	0.97	1.03	0.98	0.98	1.00	0.97	1.03	0.98
FiB index	0	1.86E-06	1.45E-06	2.59E-07	-4.14E-07	-4.14E-07	1.86E-06	1.45E-06	2.59E-07	-4.14E-07	-4.14E-07
Transfer Eff (Total)	1.98	1.96	1.98	1.96	1.99	1.98	1.96	1.98	1.96	1.99	1.98

Table 47. Trends in system statistics relative to baseline scenario. D1-D5 represent different discard scenarios R1-R5 represent different bycatch retention scenarios.. Negative trends in orange, positive in blue.

	D1	D2	D3	D4	D5	R1	R2	R3	R4	R5
Throughput	0.01	0.00	0.01	-0.01	-0.00	0.00	-0.01	-0.00	-0.01	-0.01
PCI	-0.46	-0.12	-0.33	0.21	0.06	-0.46	-0.12	-0.33	0.21	0.06
FCI	0.04	0.01	0.02	-0.02	-0.01	0.05	0.02	0.03	-0.01	0.00
Path length	-0.01	-0.00	-0.01	0.01	0.00	0.02	0.03	0.02	0.04	0.03
Export	0.26	0.16	0.10	-0.13	-0.09	-16.30	-16.41	-16.47	-16.71	-16.66
Resp	0.02	0.01	0.02	-0.01	-0.00	0.02	0.01	0.02	-0.01	-0.00
Prim prod	-0.10	-0.03	-0.07	0.04	0.02	-0.10	-0.03	-0.07	0.04	0.02
Prod	-0.07	-0.02	-0.05	0.03	0.01	-0.07	-0.02	-0.05	0.03	0.01
Biomass	-0.25	-0.10	-0.15	0.11	0.05	-0.25	-0.10	-0.16	0.11	0.05
Catch	40.01	25.12	14.44	-19.76	-12.82	40.00	25.12	14.44	-19.76	-12.82
Prop flow det	0.01	0.00	0.01	-0.01	-0.00	-0.01	-0.01	-0.01	-0.02	-0.02
Ascendency	-0.01	-0.01	-0.01	0.01	0.00	-0.01	-0.01	-0.01	0.01	0.00
Capacity	-0.08	-0.03	-0.05	0.03	0.01	-0.11	-0.06	-0.08	0.00	-0.02
A/C	0.06	0.02	0.04	-0.03	-0.01	0.09	0.05	0.07	0.00	0.02
Entropy	-0.09	-0.03	-0.05	0.04	0.02	-0.11	-0.05	-0.08	0.02	-0.01
TLc	-0.30	-0.47	0.22	0.18	0.34	-0.30	-0.47	0.22	0.19	0.34
Kempton's Q (rel.)	-0.43	1.42	-1.59	4.00	-0.64	-0.44	1.42	-1.59	4.01	-0.65
TE (Total)	-0.96	0.08	-0.99	0.51	-0.04	-0.95	0.08	-0.99	0.51	-0.03

Discussion

Changes to Biomass of Functional Groups

Despite the lack of detailed time series data specific to the region for all functional groups, reasonable fits of the model were achieved. The base model was also able show changes to the FiB index, Kempton's Q index and the mean trophic level of the catch consistent with a shift in the ecosystem in response to an expansion of the fishery and the introduction of FADs to the Gulf of Guinea,. The increase in the FiB index demonstrates that the fishery is not in balance, with larger catches of higher trophic level species (Coll *et al.*, 2008a). This pattern was also observed in the Ecopath with Ecosim model of the Warm Pool in the Pacific Ocean, where the major tuna purse seine fishery operates in the Western and Central Pacific (Griffiths, 2013). The mean TL of

catch within the Gulf of Guinea decreased during the time period in which FADs were introduced to the system. FAD sets tend to catch smaller size classes of tuna while free sets catch larger size classes of tuna on average as large yellowfin are caught in free sets (Amandè *et al.*, 2010; Fonteneau *et al.*, 2000b).

Increasing fishing pressure in both the FAD and free purse seine fleets caused the largest changes in biomass observed across the scenarios examined. This increase in fishing pressure resulted in increased biomasses of sharks, the two adult tuna functional groups and Scombridae. As scombrids and sharks are both caught as biomass in the FAD purse seine fishery and the adult tuna groups are caught in very small proportions in the free purse seine fishery, initially these results seem counter-intuitive, however when paired with the results of scenario 2 and scenario 3, which takes the two purse seine fishing modes separately, a clearer picture emerges. With just an increase in the FAD fishery, the shark and scombrid biomasses only increase slightly, 3% and 7% while increasing the free school effort causes their biomass to greatly increase (39% and 40%, respectively). This suggests that the fishing mortality resulting from being caught as bycatch in the FAD fishery prevents the biomass of some functional groups from increasing to high levels (Stevens, 2000).

When FAD fishing pressure is held constant and only the free purse seine fishing pressure is increased, the biomass of the groups caught as bycatch in the FAD fishery greatly increases, as was observed with sharks, scombrids and juvenile bigeye. Scombrids are caught in a much larger proportion by the FAD fishery than any other group as demonstrated in Chapter 2 and reported from other studies of FAD bycatch (Monin J Amandè *et al.*, 2011b; Monin *et al.*, 2008). When scombrids are released from fishing

pressure, the shark biomass can also increase as scombrids make up a major portion of the shark functional group diet. This is seen in a lag between the increases of scombrid biomass and that of the shark biomass over time (Figure 46). Biomass of scombrids under increased FAD fishing pressure (D1 and D2) begin increase in 2019 and the biomass of sharks start to increase a few years later. The shark biomass does not increase as significantly under scenario 2 as it is being caught as bycatch, even as its prey items increase slightly under scenario 2.

The increases of adult yellowfin in scenarios with increased fishing pressure is most likely also explained by the large increase in their prey species, scombrids, which in turn would cause an increase in their offspring, even with fishing pressure. For bigeye tuna, increases are seen with the exception of scenario 2. FAD fisheries catch juvenile bigeye and juvenile yellowfin in roughly the same proportions as both bycatch and catch, however, the biomass pool of the juvenile bigeye tuna is smaller than that of the yellowfin tuna.

As noted above, the biomass pools of each functional group also need to be considered when looking at shifts in biomass. Biomass of the Scombridae functional group is an order of magnitude larger than the shark functional group, making sharks much more sensitive to perturbations to their prey pool and changes in fishing effort (see Figure 7 in chapter 5 for relative biomass nodes).

It must also be noted that when the model was calibrated to the historic time series, the fits for the adult and juvenile bigeye tuna biomass had the largest SS (11.92 and 38.51, respectively). Yellowfin tuna did appear to have relatively good fits to the time series data, compared to the bigeye tuna groups. Just comparing ending and starting

biomasses does leave out certain details, most notably the initial decrease in biomass for adult and juvenile yellowfin tuna biomass with the three scenarios that increased fishing effort and an increase in biomass with the two scenarios that decreased fishing effort.

The increase in biomass from increases in FAD fishing may also be tied to competition with other predators within the model for the large bigeye tuna and yellowfin tuna groups, as there is a large reduction in the biomass of the epipelagic I functional group. This group contains other piscivores in the model, *Ruvettus pretiosus* and *Sphyraena barracuda*, so an increase in higher trophic level predators has the potential to reduce the biomass of smaller predators with a small biomass pool as productivity of functional groups dependent on their biomass size (Polovina, 1984). However, this group decreased in biomass by 16% in the absence of any fishing pressure in the baseline model, suggesting its vulnerability to predation pressure may be set too high.

The extreme changes in biomass of functional groups was not observed in Scenario 4, which represent a reduction in both free and FAD purse seine effort by 25% over 50 years. This is a more gradual reduction in fishing pressure when compared to the rate of increase of fishing pressure in scenarios 1-3. The same species with increases in biomass in response to an increase in fishing pressure slightly decreased in biomass. Interestingly, the biomass of epipelagic I did increase under scenario 4, as did carangids and skipjack tuna, suggesting that competition may be a factor with these predators on similar trophic levels (Morissette *et al.*, 2010; Trites *et al.*, 1997).

Ecopath and Ecosim models are extremely sensitive to the initial diet matrix as the settings determine the starting predation mortality rates and the effective search rate for prey within Equation 21 (Cox *et al.*, 2002a, 2002b). The diet matrix for the majority

of the functional groups relied upon data from outside the system as there have been few detailed studies examining the stomach content . More robust predictions about the changes seen in biomass of the functional groups could potentially be obtained through a more complete diet composition matrix. Diet studies have been conducted on tunas caught by the purse seine fleet in the South Sherbro Area, which found the majority of the diet of small tunas came from mesopelagic fish species (Bard *et al.*, 2002; Ménard and Marchal, 2003; M Potier *et al.*, 2007). The diet composition of the small tunas, skipjack, juvenile yellowfin and bigeye, was similar across size classes, regardless of species. The major species of mesopelagic fish identified in the stomachs, *Vinciguerria nimbaria*, undergoes a vertical diel migration. The base model did take into account this vertical migration for some components of the functional groups, however the model is parameterized for the epipelagic zone and does not take into account all the biomass of the mesopelagic species that undergo diel, vertical migrations.

Large tuna are opportunistic predators and their diet depends on what is encountered depending on the season and area. From the South Sherbro diet study, the major component of the diet of large yellowfin tuna was scombrid species (Ménard and Marchal, 2003). Yellowfin above 90 cm were found to feed almost exclusively on scombrids, including frigate tuna. The scombrid biomass in the model greatly increased when fishing effort was increased while the biomass of adult yellowfin tuna and bigeye tuna increased slightly, suggesting that the productivity of the scombrid species are far higher than that of the targeted tuna.

Changes to Ecosystem

Ecosystem statistics and ecosystem indices were different between models where bycatch was discarded and those where bycatch was retained. The amount of bycatch exported from the system as a result of fishing, however, was small compared to the overall biomass and flows within the system. The changes observed in the system indices were small but differed between the discarded/retained models. Some of the indices that were consistent with degraded ecosystem within the discarded model exhibited opposite patterns in the retained model, most notably proportion of flow to detritus and the export within the system. The flow to detritus increased in the discarded model, which is an indicator of a declining ecosystem (Coll *et al.*, 2008b; Shannon *et al.*, 2009), however this is most likely the result of the discard, detritus groups increasing in biomass in the discard model. In the retained discard model, this biomass is exported from the system and does not enter back into the detritus pool.

Exports increased in the discarded model when fishing pressure increased which is the expected response as fisheries export energy from the ecosystem that cannot be recycled (Coll *et al.*, 2008a). When fishing pressure was reduced in the discard model, exports decreased. However, in the retention model, exports decreased across all scenarios, which may be a factor with how exports are calculated within the Ecopath routines.

The path length also exhibited a positive trend within the retained model for all scenarios, in contrast to the discard models. Path length is a measure of how much energy is recycled within the system. Ecosystems with higher amounts of recycling are thought

to better able to withstand outside pressure to the system from fishing (Vasconcellos *et al.*, 1997), suggesting bycatch retention and throwing dead discards back to sea could theoretically improve ecosystem functioning.

Increasingly, the need for managing the impact of fishing at the ecosystem level is being recognized and the traditional management paradigm of increasing selectivity is being re-examined (Garcia *et al.*, 2003; Zhou *et al.*, 2010). As fishing gears become more advanced, it is easier to select only the species and sizes that are desirable to fishers and the market. This selectivity can be beneficial to prevent growth overfishing, minimize catches of undersized/juvenile individuals, reducing waste associated with bycatch and discards as well as minimizing the impacts on sensitive species like sharks and turtles (Zhou *et al.*, 2010). However, fishing gear can select sizes and sexes in differing proportion to what would be killed through predation or natural mortality (Garcia *et al.*, 2012). This can create changes in the targeted population and eventually throughout the ecosystem. Interest has turned to the concept of balanced fishing, fishing across different sizes and species, as a way to mitigate these impacts. Rochet and Benoit (2012) simulated impacts from selective fishing along a size spectrum and found these effects were larger when fishing pressure was more selective as well as when larger size classes were targeted.

The traditional method of selectivity is termed “6-S” selection: species, stock, size, sex, season and space. It is now being thought that this management technique may be increasing the negative impacts on populations and ecosystem functions rather than lessening it (Zhou *et al.*, 2010). Species selection by fisheries targeting single populations could lead to increased natural mortality by increasing the probability of predator-prey

interactions as well as increased competition with comparable trophic level populations occupying overlapping niches. The removals by the longline and purse seine fleets in the ETP EwE model of large predators, tuna, billfish and sharks, were followed by increases in *Auxis* and mahi-mahi while removal of large predators in the CNP model caused declines in small scombrid species as well as mahi-mahi (Hinke *et al.*, 2004; Olson and Watters, 2003).

The purpose of comparing the fate of bycatch species through the discarded and retained model was two-fold. The first objective was to examine the response of the ecosystem to the development of incentives (through measures such as encouraging full retention of bycatch) for fishermen to avoid catching bycatch. The second objective was to examine the concept of balanced fishing by removing a cross-section of different functional groups completely from an ecosystem. A final caveat in the modeling approach used for this study is that the only fishing effort used to drive the model was from purse seine fleets. While this allowed the effects from the two modes of purse seine fishing to be examined in isolation, the interactive effects of the other two fisheries were not considered. The purse seine fleets are the largest fishing fleets in the region, however, there is also an artisanal fleet that targets some of the same species that was not included in the model due to lack of data and because the artisanal fleet operates closer to the coastline. The baitboat fishery in the region provides a large source of fishing mortality, however this fleet can also act as a de facto FAD purse seine fleet as baitboat vessels are

used as the actual FAD and catches are made around them by purse seiners (Hallier and Delgado de Molina, 2000). In the base Ecopath model, this was accounted for in the landings for FAD purse seine fleet as some country's bait boat landings were assigned to the FAD fishery.

Conclusions

The Gulf of Guinea ECOSIM model had reasonable fits to historic trends observed in catches and biomass for the region. The model was able to simulate the catches and biomass of skipjack extremely well, which is promising for future applications of the model. Shifts in the biomass of the catches of the Gulf of Guinea were captured by the FiB, TL_c and Kempton's Q indices, further validating the major assumptions of the model. The scenarios used to represent potential shifts in fishing effort provided further insight into how different modes of purse seine fishing may be interacting with the predator-prey dynamics of the ecosystem. This model can be also be modified to take into account other fisheries in the region and to further explore management recommendation proposed or newly adopted by ICCAT.

Building the Gulf of Guinea Ecopath and Ecosim models highlights the lack of information on an ecosystem that is undergoing an expansion in resource utilization, not only in terms of fisheries but also with in term of an expansion of oil extraction at sea from oil platforms. The fact remains that this ecosystem may have undergone changes without us having an opportunity to have examined its baseline conditions. Regardless, this study shows that there is an opportunity for study of the pelagic ecosystem of this region so as to support future fishery management decisions.

Chapter 7: Conclusion

The shift towards an ecosystems approach to fisheries management has resulted in more attention focused on both the amounts and fate of bycatch species. The major questions this dissertation sought to answer for the Gulf of Guinea were: 1) how do the different modes of purse seine fishing affect the species caught by this gear? 2) how do such gear/species interactions then affect the ecosystem? This dissertation shows that the chief driver of changes to the overall ecosystem function and structure is the amount of bycatch caught by purse seine vessels and this amount largely depends on the type of fishing set employed, FAD or free.

The Bayesian imputation methods to find missing ratio estimators was a statistically rigorous method to estimate total bycatch in sets that are not observed. The estimated bycatch biomass was larger for FAD sets than for free sets, as a result, more teleosts that are part of the bycatch are affected by fishing on FADs than by fishing on free schools. As more fish encounter the purse seine in FAD sets, a greater number suffer immediate mortality because they are retained on board. At the same time a greater proportion of the bycatch caught on FADs is discarded and thus a higher number of fish suffer delayed mortality as a consequence of FAD sets in comparison to free schools sets.

Estimated historical shifts in biomass and yields of certain functional groups and on ecosystem function, were mainly the result of changes in fishing effort by the purse seine fleets, and the increasing ratio FAD vs free sets, rather than as a consequence on how the bycatch was treated once caught. The use of impaired reflexes, however,

provides a rapid and effective way for total mortality to be estimated by both scientists and observers. This method should be applied to many more bycatch species to confirm that estimated impacts of purse seine fishing are not that sensitive to the fate of discards.

The issue of food security in relation to the discards of bycatch has been raised by Pacific Island Nations in the western and central Pacific Ocean, where the largest tuna purse seine fishery operates (Bell *et al.*, 2015; Pilling *et al.*, 2015). If bycatch species are caught in the fishing process, it is perhaps more beneficial to retain the bycatch as a food source, as there is little observable benefit for the ecosystem to discard the bycatch into the detritus pool. The strategy of reducing bycatch through required retention of all catches has been adopted, most notably by Norway, Iceland and recently the European Union; however the retention of all species brought onboard can cause the mortality of species that could otherwise survive the fishing process as was seen with triggerfish in chapter 3. In the Gulf of Guinea model, the ecosystem function indicators change little whether the bycatch is discarded at sea or retained. This may be related to the widespread practice in the eastern tropical Atlantic of landing many species normally discarded at sea in other regions. These fish, sold for local consumption in the markets of West Africa and known as “*faux poisson*”, are already retained on board by many Atlantic purse seiners.

The challenges faced in developing both the equilibrium Ecopath model and the time dynamic Ecosim model of the Gulf of Guinea highlight the paucity of data available for a region that supports a major fishery and is an important nesting and breeding ground for several ecologically sensitive species. While the model was able to capture some important shifts within the ecosystem, the data used to parameterize both

capture some important shifts within the ecosystem, the data used to parameterize both the Ecopath and Ecosim models were for the most part fisheries dependent. There is a strong need for high quality, basic research in the region so as to better describe the ecosystem and improve our understanding of the impacts that the tuna fishery exerts upon it. Without substantial improvements on abundance estimates and additional time series data for the lower trophic levels in the region, it is unlikely that the uncertainty of the predictions on the effects of fishing on the Gulf of Guinea ecosystem can be reduced.

Placed in the larger context of bycatch rates of other fisheries, notably trawl fisheries and longlines, the bycatch caught through the use of purse seines is relatively low. The ocean, however, contains a finite amount of interconnected resources and any biomass removal through fishing can have unintended and undesirable consequences that, like it is done for the Gulf of Guinea in this dissertation, needs to be evaluated.

References

- Aggrey-Fynn J (2009) Distribution and growth of grey triggerfish, *Balistes capriscus* (Family: Balistidae), in western Gulf of Guinea. *West African J Applied Ecol* 15.
- Ainsworth CH, Pitcher TJ (2006) Modifying Kempton's species diversity index for use with ecosystem simulation models. *Ecol Indic* 6: 623–630.
- Allen R, Joseph J, and Squires D (eds) (2010) Conservation and Management of Transnational Tuna Fisheries, Wiley-Blackwell, Oxford, UK.
- Allesina S, Ulanowicz RE (2004) Cycling in ecological networks: Finn's index revisited. *Comput Biol Chem* 28: 227–233.
- Amandè MJ, Ariz J, Chassot E, Chavance P, de Molina AD, Gaertner D, Murua H, Pianet R, Ruiz J (2011) Bycatch of the European purse seine tuna fishery in the Atlantic Ocean: estimation and characteristics for 2008 and 2009. *Collect Vol Sci Pap ICCAT* 66: 2113–2120.
- Amandè MJ, Ariz J, Chassot E, Chavance P, Molina AD De, Gaertner D, Murua H, Pianet R, Ruiz J (2011) By-catch and discards of the European purse seine tuna fishery in the Atlantic Ocean: estimation and characteristics for 2008 and 2009. *Collect Vol Sci Pap ICCAT* 66: 2113–2120.
- Amandè MJ, Ariz J, Chassot E, Molina AD De, Gaertner D, Murua H, Pianet R, Ruiz J, Chavance P (2010) Bycatch of the European purse seine tuna fishery in the Atlantic Ocean for the 2003 – 2007 period. *Aquat Living Resour* 4: 353–362.
- Amandè MJ, Chassot E, Chavance P, Murua H, de Molina a. D, Bez N (2012) Precision in bycatch estimates: the case of tuna purse-seine fisheries in the Indian Ocean. *ICES J Mar Sci* 69: 1501–1510.
- Amandè MJ, Lennert-Cody CE, Bez N, Hall M, Chassot E (2010) How much sampling coverage affects bycatch estimates in purse seine fisheries? *IOTC WP Ecosysteme Bycatch*.
- Anonymous (2000) A review of the biology of the family Carangidae , with emphasis on species found in Hawaiian waters. *October* 1–43.
- Anonymous (2009) Report of the 2008 ICCAT yellowfin and skipjack stock assessment meeting. *Collect VolSci Pap ICCAT* 64: 669–927.
- Anonymous (2010a) Report of the 2009 sailfish stock assessment. *Collect Vol Sci Pap ICCAT* 65: 1507–1632.

- Anonymous (2010b) Report of the 2010 ICCAT bigeye tuna stock assessment session. *BET Stock Assess Pasaia, Gi.*
- Anonymous (2011a) Report of the 2011 blue marlin stock assessment and white marlin data preparatory meeting. *Collect Vol Sci Pap ICCAT.*
- Anonymous (2011b) Report of the 2011 ICCAT yellowfin tuna stock assessment session. *Collect Vol Sci Pap ICCAT 68: 655–817.*
- Anonymous (2011c) Report of the 2010 ICCAT bigeye tuna stock assessment session. *Collect Vol Sci Pap ICCAT 66: 1–186.*
- Anonymous (2013) Report of the 2013 Atlantic swordfish stock assessment session. *Collect Vol Sci Pap ICCAT.*
- Anonymous (2014a) Report of the 2013 Atlantic swordfish stock assessment session. *Collect VolSci Pap ICCAT 70: 1484–1678.*
- Anonymous (2014b) Report of the 2014 ICCAT east and west Atlantic skipjack stock assessment meeting. *Collect Vol Sci Pap ICCAT.*
- Anonymous (2014c) Report of the 2013 ICCAT data preparatory meeting for Atlantic albacore. *Collect Vol Sci Pap ICCAT 70: 717–829.*
- Archer FI, Gerrodette T, Chivers SJ, Jackson A (2002) Annual estimates of the unobserved incidental kill of pantropical spotted dolphin in the tuna purse-seine fishery of the eastern tropical Pacific. *Fish Sci 233–244.*
- Arrizabalaga H, Ortiz M, Moreno G, Kell LT, Rodri C (2003) Standardization of bluefin tuna , *Thunnus thynnus* , catch per unit effort in the baitboat fishery of the Bay of Biscay (Eastern Atlantic). *ICES J Mar Sci 60: 1216–1231.*
- Babcock E a, Pikitch EK (2003) How much observer coverage is enough to adequately estimate bycatch? *Methodology 1–36.*
- Bakun A (2006) Fronts and eddies as key structures in the habitat of marine fish larvae : opportunity , adaptive response. *Sci Mar 70S2: 105–122.*
- Bamy IL, Van Waerebeek K, Bah SS, Dia M, Kaba B, Keita N, Konate S (2010) Species occurrence of cetaceans in Guinea, including humpback whales with southern hemisphere seasonality. *Mar Biodivers Rec 3: 1–10.*
- Bard FX, Kouame B, Herve A (2002) Schools of large yellowfin (*Thunnus Albacares*) concentrated by foraging on a monospecific layer of *Cubiceps Pauciradiatus* observed in the eastern tropical Atlantic. *Collect Vol Sci Pap ICCAT 54: 33–41.*

- Barrett RT, Camphuysen K, Anker-Nilssen T, Chardine JW, Furness RW, Garthe S, Hüppop O, Leopold MF, Montevecchi WA, Veit RR (2007) Diet studies of seabirds: A review and recommendations. *ICES J Mar Sci* 64: 1675–1691.
- Bartholomew A, Bohnsack JA (2005) A review of catch-and-release angling mortality with implications for no-take reserves. *Rev Fish Biol Fish* 15: 129–154.
- Barton BA (2002) Stress in fishes: a diversity of responses with particular reference to changes in circulating corticosteroids. *Integr Comp Biol* 42: 517–25.
- Baum JK, Blanchard W (2010) Inferring shark population trends from generalized linear mixed models of pelagic longline catch and effort data. *Fish Res* 102: 229–239.
- Bell JD, Allain V, Allison EH, Andréfouët S, Andrew NL, Batty MJ, Blanc M, Dambacher JM, Hampton J, Hanich Q, *et al.* (2015) Diversifying the use of tuna to improve food security and public health in Pacific Island countries and territories. *Mar Policy* 51: 584–591.
- Bohnsack J a. (2000) A comparison of the short-term impacts of no-take marine reserves and minimum size limits. *Bull Mar Sci* 66: 635–650.
- Borges L, Zuur a. F, Rogan E, Officer R (2005) Choosing the best sampling unit and auxiliary variable for discards estimations. *Fish Res* 75: 29–39.
- Branstetter S (1987) Age, growth and reproductive biology of the silky shark, *Carcharhinus falciformis*, and the scalloped hammerhead, *Sphyrna lewini*, from the northwest Gulf of Mexico. *Environ Biol Fishes* 19: 161–173.
- Branstetter S (1987) Age and Growth Estimates for Blacktip, *Carcharhinus limbatus*, and Spinner, *C. brevipinna*, Sharks from the Northwestern Gulf of Mexico. *Copeia* 4: 964–974.
- Bromhead D, Foster J, Attard R, Findlay J, Kalish J (2003) A Review of the impact of fish aggregating devices (FADs) on tuna fisheries: Final Report to Fisheries Resource Research Fund. *Fish Resour Res Fund, Commonw Aust* 1–121.
- Brown RG., Barker SP, Gaskin DE, Sandeman MR (1981) The foods of great and sooty shearwaters *Puffinus gravis* and *P. griseus* in eastern Canadian waters. *Br Ornithol Union* 19–30.
- Burgess GH, Beerkircher, Lawerance R, Cailliet GM, Carlson JK, Cortés E, Goldman KJ, Grubbs RD, Musick J a., Musyl MK, Simpfendorfer C a. (2005) Is the collapse of shark populations in the Northwest Gulf of Mexico Atlantic. *Fisheries* 30: 19–26.
- Burnham, KP, Anderson DR. (2002) *Model selection and multimodel inference: a practical information-theoretic approach*. Springer Science & Business Media.

- Butler PJ, Taylor EW, Davison W (1979) The effect of long term, moderate hypoxia on acid-base balance, plasma catecholamines and possible anaerobic end products in the unrestrained dogfish *Scyliorhinus canicula*. *J Comp Physiol* 132: 279–303.
- Cabrera-Chávez-Costa A., Galván-Magaña F, Escobar-Sánchez O (2010) Food habits of the silky shark *Carcharhinus falciformis* (Müller & Henle, 1839) off the western coast of Baja California Sur, Mexico. *J Appl Ichthyol* 26: 499–503.
- Cailliet GM, Martin LK, Harvey JT, Kusher D, Weldon B (1983) Preliminary studies on the age and growth of blue, *Prionace glauca*, Common Thresher, *Alopias vulpinus*. In: Prince ED & LM Pulos (eds). Proceedings of the International Workshop on Age Determination of Oceanic Pelagic Fishes: Tunas, Billfishes and Sharks. NOAA Technical Report NMFS. pp 179–188.
- Cameron JN (1978) Regulation of blood pH in teleost fish. *Respir Physiol* 33: 129–144.
- Campbell MD, Patino R, Tolan J, Strauss R, Diamond SL (2010) Sublethal effects of catch-and-release fishing : measuring capture stress , fish impairment , and predation risk using a condition index. *ICES* 67: 513–521.
- Carranza A, Domingo A, Estrades A (2006) Pelagic longlines: A threat to sea turtles in the Equatorial Eastern Atlantic. *Biol Conserv* 131: 52–57.
- Castro JJ, Santiago JA, Pla C (1999) Growth and reproduction of the dolphinfish (*Coryphaena equiselis* and *Coryphaena hippurus*) in the Canary Islands, Central-East Atlantic (preliminary results). *Sci Mar* 63: 317–325.
- Castroviejo J, Juste J, Val JP del, Castelo R, Gil R (1994a) Diversity and status of sea turtle species in the Gulf of Guinea islands. *Biodivers Conserv* 836: 828–836.
- Castroviejo J, Juste J, Val JP del, Castelo R, Gil R (1994b) Diversity and status of sea turtle species in the Gulf of Guinea islands. *Biodivers Conserv* 3: 828–836.
- Chassot E, Dewals P, Floch L, Lucas V, Morales-Vargas M, Kaplan D (2010) Analysis of the effects of Somali piracy on the European tuna purse seine fisheries of the Indian Ocean. *IOTC Sci Comm* IOTC-2010-.
- Chavance P, Baptiste J, Kothias A, Dewals P, Pianet R (2011) Statistics on tuna surface fishery's bycatch landed in Abidjan, Côte d'Ivoire, for the 1982-2009 period. *Collect Vol Sci Pap ICCAT* 66: 2104–2112.
- Chavance P, Dewals P, Amande MJ, Delgado de Molina A, Damiano A, Tamegnon A (2015) Tuna fisheries catch landed in Abidjan (Côte d'Ivoire) and sold on local fish market for the period 1982-2013 (preliminary data). *Collect Vol Sci Pap ICCAT* 71: 183–188.
- Christensen V (2004) Placing fisheries in their ecosystem context, an introduction. *Ecol Modell* 172: 103–107.

- Christensen V, Beattie A, Buchanan C, Ma H, Martell SJD, Latour RJ, Preikshot D, Sigrist MB, Uphoff JH, Walters CJ, *et al.* (2009) Fisheries ecosystem model of the Chesapeake Bay: Methodology, parameterization, and model exploration. *NOAA Tech Memo*.
- Christensen V, Walters CJ (2004) Ecopath with Ecosim: methods, capabilities and limitations. *Ecol Modell* 172: 109–139.
- Christensen V, Walters CJ, Pauly D (2005) Ecopath with Ecosim: A User's Guide. Fisheries (Bethesda).
- Chyan-huei Lo N, Jacobson LD, Squire JL (1992) Indices of relative abundance from fish spotter data based on delta-lognormal models. *Can J Fish Aquat Sci* 49: 2515–2526.
- Clarke SC, McAllister MK, Michielsens CGJ (2005) Estimates of shark species composition and numbers associated with the shark fin trade based on Hong Kong auction data. *J Northwest Atl Fish Sci* 35: 453–465.
- Clarke SC, McAllister MK, Milner-Gulland EJ, Kirkwood GP, Michielsens CGJ, Agnew DJ, Pikitch EK, Nakano H, Shivji MS (2006) Global estimates of shark catches using trade records from commercial markets. *Ecol Lett* 9: 1115–26.
- Coelho R, Fernandez-Carvalho J, Amorim S, Santos MN (2011) Age and growth of the smooth hammerhead shark, *Sphyrna zygaena*, in the Eastern Equatorial Atlantic Ocean, using vertebral sections. *Aquat Living Resour* 24: 351–357.
- Coll M, Bundy A, Shannon LJ (2009) Computers in Fisheries Research.
- Coll M, Libralato S, Tudela S, Palomera I, Pranovi F (2008a) Ecosystem overfishing in the ocean. *PLoS One* 3: e3881.
- Coll M, Navarro J, Olson RJ, Christensen V (2013) Assessing the trophic position and ecological role of squids in marine ecosystems by means of food-web models. *Deep Res Part II Top Stud Oceanogr* 95: 21–36.
- Coll M, Palomera I, Tudela S, Dowd M (2008b) Food-web dynamics in the South Catalan Sea ecosystem (NW Mediterranean) for 1978–2003. *Ecol Modell* 217: 95–116.
- Coll M, Palomera I, Tudela S, Sarda F (2006) Trophic flows, ecosystem structure and fishing impacts in the South Catalan Sea, Northwestern Mediterranean. *J Mar Syst* 59: 63–96.
- Coll M, Santojanni A, Palomera I, Tudela S, Arneri E (2007) An ecological model of the Northern and Central Adriatic Sea: Analysis of ecosystem structure and fishing impacts. *J Mar Syst* 67: 119–154.

- Collette BB, Carpenter KE, Polidoro B a, Juan-Jordá MJ, Boustany A, Die DJ, Elfes C, Fox W, Graves J, Harrison LR, *et al.* (2011) High value and long life-double jeopardy for tunas and billfishes. *Science (80)* 333: 291–2.
- Cortés E, Arocha F, Beerkircher L, Carvalho F, Domingo A, Heupel M, Holtzhausen H, Santos MN, Ribera M, Simpfendorfer C (2010) Ecological risk assessment of pelagic sharks caught in Atlantic pelagic longline fisheries. *Aquat Living Resour* 23: 25–34.
- Cotter AJR, Pilling GM (2007) Landings, logbooks and observer surveys: improving the protocols for sampling commercial fisheries. *Fish Fish* 8: 123–152.
- Couturier LIE, Marshall AD, Jaine FRA, Kashiwagi T, Pierce SJ, Townsend KA, Weeks SJ, Bennett MB, Richardson AJ (2012) Biology, ecology and conservation of the Mobulidae. *J Fish Biol* 80: 1075–1119.
- Cox SP, Essington TE, Kitchell JF, Martell SJD, Walters CJ, Boggs C, Kaplan I (2002a) Reconstructing ecosystem dynamics in the central Pacific Ocean , 1952 – 1998. II. A preliminary assessment of the trophic impacts of fishing and effects on tuna dynamics. *Fish Sci* 59: 1736–1747.
- Cox SP, Martell SJD, Walters CJ, Essington TE, Kitchell JF, Boggs C, Kaplan I (2002b) Reconstructing ecosystem dynamics in the central Pacific Ocean , 1952 – 1998 . I . Estimating population biomass and recruitment of tunas and billfishes. *Can J Fish Aquat Sci* 59: 1724–1735.
- Criales-Hernandez M, Duarte L, Garcia C, Manjarres L (2006) Ecosystem impacts of the introduction of bycatch reduction devices in a tropical shrimp trawl fishery: Insights through simulation. *Fish Res* 77: 333–342.
- Crowder LB, Murawski SA (1998) Fisheries bycatch: Implications for management. *Fish Manag* 23: 8–17.
- Croxall JP, Prince PA (1996) Cephalopods as prey I. Seabirds. *Philos Trans R Soc B Biol Sci* 351: 1023–1043.
- Dagorn L, Filmalter JD, Forget F, Amandè MJ, Hall MA, Williams P, Murua H, Ariz J, Chavance P, Bez N (2012) Targeting bigger schools can reduce ecosystem impacts of fisheries. *Can J Fish Aquat Sci* 69: 1463–1467.
- Dagorn L, Holland KN, Filmalter J (2010) Are drifting FADs essential for testing the ecological trap hypothesis ? *Fish Res* 106: 60–63.
- Dagorn, L et al (in prep). Effects of fish aggregating devices (DFADs) on the behavior and biology of tropical tunas.

- Damiano A, Molinaa D De, Murua H, Ruiz J, Santana JC (2014) Notes on billfishes caught during observer program on European purse seiners in the Atlantic Ocean (2003-2012). *Collect Vol Sci Pap ICCAT* 70: 2481–2485.
- Danylchuk AJ, Suski CD, Mandelman JW, Murchie KJ, Haak CR, Brooks AML, Cooke SJ (2014) Hooking injury, physiological status and short-term mortality of juvenile lemon sharks (*Negaprion brevirostris*) following catch-and-release recreational angling. *Conserv Physiol* 2: 1–10.
- Danylchuk SE, Danylchuk AJ, Cooke SJ, Goldberg TL, Koppelman J, Philipp DP (2007) Effects of recreational angling on the post-release behavior and predation of bonefish (*Albula vulpes*): The role of equilibrium status at the time of release. *J Exp Mar Bio Ecol* 346: 127–133.
- Davies RWD, Cripps SJ, Nickson a., Porter G (2009) Defining and estimating global marine fisheries bycatch. *Mar Policy* 33: 661–672.
- Davis M (2001) Stress induced by hooking, net towing, elevated sea water temperature and air in sablefish: lack of concordance between mortality and physiological measures of stress. *J Fish Biol* 58: 1–15.
- Davis MW (2002) Key principles for understanding fish bycatch discard mortality. *Can J Fish Aquat Sci* 59: 1834–1843.
- Davis MW (2007) Simulated fishing experiments for predicting delayed mortality rates using reflex impairment in restrained fish. *ICES J Mar Sci* 64: 1535–1542.
- Davis MW (2010) Fish stress and mortality can be predicted using reflex impairment. *Fish Fish* 11: 1–11.
- Davis MW, Ottmar ML (2006) Wounding and reflex impairment may be predictors for mortality in discarded or escaped fish. *Fish Res* 82: 1–6.
- Dayton PK, Thrush SF, Agardy MT, Hofman RJ (1995) Environmental effects of marine fishing. *Aquat Conserv Mar Freshw Ecosyst* 5: 205–232.
- Dempster T, Kingsford MJ (2003) Homing of pelagic fish to fish aggregation devices (FADs): the role of sensory cues. *Mar Ecol Prog Ser* 258: 213–222.
- Dempster T, Taquet M (2004) Fish aggregation device (FAD) research : gaps in current knowledge and future directions for ecological studies. *Rev Fish Biol Fish* 14: 21–42.
- Depestele J, Vandemaele S, Vanhee W, Polet H, Torreele E, Leirs H, Vincx M (2011) Quantifying causes of discard variability: an indispensable assistance to discard estimation and a paramount need for policy measures. *ICES J Mar Sci* 68: 1719–1725.

- Dragovich A (1966) The food of skipjack and yellowfin tunas. *Fish Bull* 68: 445–460.
- Dulvy NK, Baum JK, Clarke S, Compagno LJ V, Cortés E, Domingo A, Fordham S, Fowler S, Francis MP, Gibson C, *et al.* (2008) You can swim but you can't hide: The global status and conservation of oceanic pelagic sharks and rays. *Aquat Conserv Mar Freshw Ecosyst* 18: 459–482.
- Essington TE (2007) Evaluating the sensitivity of a trophic mass- balance model (Ecopath) to imprecise data inputs. *Can J Fish Aquat Sci* 64: 628–637.
- Essington TE, Schindler DE, Olson RJ, Kitchell JF, Boggs C, Hilborn R (2002) Alternative fisheries and the predation rate of yellowfin tuna in the eastern Pacific ocean. *Ecol Appl* 12: 724–734.
- FAO (2014) The State of World Fisheries and Aquaculture. Food and Agriculture Organization of the United Nations.
- Fetahi T, Mengistou S (2007) Trophic analysis of Lake Awassa (Ethiopia) using mass-balance Ecopath model. *Ecol Modell* 201: 398–408.
- Filmalter JD, Capello M, Deneubourg JL, Cowley PD, Dagorn L (2013) Looking behind the curtain: Quantifying massive shark mortality in fish aggregating devices. *Front Ecol Environ* 11: 291–296.
- Fonteneau A, Ariz J, Gaertner D, Nordstrom V, Pallares P (2000a) Observed changes in the species composition of tuna schools in the Gulf of Guinea between 1981 and 1999, in relation with the Fish Aggregating Device fishery. *Aquat Living Resour* 13: 253–257.
- Fonteneau A, Ariz J, Gaertner D, Nordstrom V, Pallares P (2000b) Observed changes in the species composition of tuna schools in the Gulf of Guinea between 1981 and 1999 , in relation with the Fish Aggregating. *Aquat Living Resour* 13: 253–257.
- Fonteneau A, Chassot E, Bodin N (2013) Global spatio-temporal patterns in tropical tuna purse seine fisheries on drifting fish aggregating devices (DFADs): Taking a historical perspective to inform current challenges. *Aquat Living Resour* 26: 37–48.
- Forget FG, Capello M, Filmalter JD, Govinden R, Soria M, Cowley PD, Dagorn L (2015) Behaviour and vulnerability of target and non-target species at drifting fish aggregating devices (FADs) in the tropical tuna purse seine fishery determined by acoustic telemetry. *Can J Fish Aquat Sci* 72: 1398–1405.
- Forrestal F, Coll M, Die D, Christensen V (2012) Ecosystem effects of bluefin tuna *Thunnus thynnus thynnus* aquaculture in the NW Mediterranean Sea. *Mar Ecol Prog Ser* 456: 215–231.
- Franks JS, Vanderkooy KE, Garber NM (2003) Diet of tripletail, *Lobotes surinamensis*, from Mississippi coastal waters. *Gulf Caribb Res* 15: 27–32.

- Freon P, Dagorn L (2000) Review of fish associative behaviour : toward a generalisation of the meeting point hypothesis. *Rev Fish Biol Fish* 183–207.
- Froese R, Pauly eds. (2015) FishBase. World Wide Web electronic publication. www.fishbase.org, accessed 10/2015.
- Fulton E, Smith A, Punt A (2005) Which ecological indicators can robustly detect effects of fishing? *ICES J Mar Sci* 62: 540–551.
- Gabriel WL, Mace PM (1999) A review of biological reference points in the context of the precautionary approach. *Proc fifth Natl NMFS Stock Assess Work Provid Sci advice to implement precautionary approach under Magnuson-Stevens Fish Conserv Manag act NOAA Tech Memo NMFS-F/SPO-40* 34–45.
- Gaertner D, Menard F, Develter C, Ariz J, Delgado de Molina A (2002) Bycatch of billfishes by the European tuna purse-seine fishery in the Atlantic Ocean. *Fish Bull* 100: 683–689.
- Gallagher AJ, Frick LH, Bushnell PG, Brill RW, Mandelman JW (2010) Blood gas, oxygen saturation, pH, and lactate values in elasmobranch blood measured with a commercially available portable clinical analyzer and standard laboratory instruments. *J Aquat Anim Health* 22: 229–34.
- Garcia ER, Potts JC, Rulifson R, Manooch CS (2003) Age and Growth of Yellowtail Snapper , *Ocyurus Chrysurus* , From the Southeastern United States. *Bull Mar Sci* 72: 909–921.
- Garcia SM (Ed) (2010) Selective Fishing and Balanced Harvest in Relation to Fisheries and Ecosystem Sustainability. *IUCN*.
- Garcia SM, Zerbi A, Aliaume C, Do Chi T, Lasserre G (2003) The ecosystem approach to fisheries. Issues, terminology, principles, institutional foundation, implementation and outlook. *FAO Fish Tech Pap* No. 443: 71p.
- Gardner B, Sullivan PJ, Epperly S, Morreale SJ (2008) Hierarchical modeling of bycatch rates of sea turtles in the western North Atlantic. *Endanger Species Res* 5: 279–289.
- Gasalla MA, Rossi-Wongtschowski CLDB (2004) Contribution of ecosystem analysis to investigating the effects of changes in fishing strategies in the South Brazil Bight coastal ecosystem. *Ecol Modell* 172: 283–306.
- Gerrodette T, Olson R, Reilly S, Watters G, Perrin W (2012) Ecological metrics of biomass removed by three methods of purse-seine fishing for tunas in the eastern tropical Pacific Ocean. *Conserv Biol* 26: 248–56.
- Gezelius SS (2008) Management responses to the problem of incidental catch in fishing: A comparative analysis of the EU, Norway, and the Faeroe Islands. *Mar Policy* 32: 360–368.

- Gibbs RH, Collette BB (1959) On the identification, distribution, and the biology of the dolphins, *Coryphaena hippurus* and *C. euiselis*. *Bull Mar Sci Gulf Caribb* 9: 117–152.
- Gilman E, Suuronen P, Hall M, Kennelly S (2013) Causes and methods to estimate cryptic sources of fishing mortality. *J Fish Biol* 83: 766–803.
- Gilman EL (2011) Bycatch governance and best practice mitigation technology in global tuna fisheries. *Mar Policy* 35: 590–609.
- Gingerich AJ, Cooke SJ, Hanson KC, Donaldson MR, Hasler CT, Suski CD, Arlinghaus R (2007) Evaluation of the interactive effects of air exposure duration and water temperature on the condition and survival of angled and released fish. *Fish Res* 86: 169–178.
- Goñi N, Logan J, Arrizabalaga H, Jarry M, Lutcavage M (2011) Variability of albacore (*Thunnus alalunga*) diet in the Northeast Atlantic and Mediterranean Sea. *Mar Biol* 158: 1057–1073.
- Goodwin JM, Johnson AG (1986) Age, growth, and mortality of blue runner, *Caranx crysos* from the northern Gulf of Mexico. *Northeast Gulf Sci* 8: 107–114.
- Graham BS, Grubbs D, Holland K, Popp BN (2006) A rapid ontogenetic shift in the diet of juvenile yellowfin tuna from Hawaii. *Mar Biol* 150: 647–658.
- Griffiths SP (2013) Simulated ecological effects of purse seine fisheries on the Pacific Warm Pool ecosystem. *Final Rep Prep Secr Pacific Community*.
- Guénette S, Christensen V, Pauly D (2001) Fisheries impacts on North Atlantic ecosystems: models and analyses. *Fisheries Centre Research Reports*, 9(4), 111–127.
- Gunn JS (1990) A revision of selected genera of the family Carangidae (Pisces) from Australian waters. *Rec Aust Museum, Suppl* 12: 1–77.
- Hall M, Roman M (2013) Bycatch and non-tuna catch in the tropical tuna purse seine fisheries of the world. *FAO Fish Aquac Pap* 586: 249.
- Hall MA (1995) Strategies to Reduce the Incidental Capture of Marine Mammals and Other Species in Fisheries. In: *East Coast Bycatch Proceedings*. p 3.
- Hall MA, Alverson DL, Metuzals KI (2000) By-Catch: Problems and Solutions. *Mar Pollut Bull* 41: 204–219.
- Hall SJ, Mainprize B (2004) Towards ecosystem-based fisheries management. *Fish Fish* 5: 1–20.
- Hallier J, Gaertner D (2008) Drifting fish aggregation devices could act as an ecological trap for tropical tuna species. *Mar Ecol Prog Ser* 353: 255–264.

- Hallier Jean-Pierre, Delgado De Molina A (2000). Baitboat as a tuna aggregating device. Pêche thonière et dispositifs de concentration de poissons, Caribbean-Martinique, 15-19 Oct 1999.
- Harter TS, Shartau RB, Brauner CJ, Farrell AP (2014) Validation of the i-STAT system for the analysis of blood parameters in fish. *Conserv Physiol* 2: cou037–cou037.
- Hays GC, Hobson VJ, Metcalfe JD, Righton D, Sims W, Hays C, Hobson J, Metcalfe D (2014) Flexible foraging movements of leatherback turtles across the North Atlantic Ocean. *Ecology* 87: 2647–2656.
- Hazevoet CJ, Wenzel FW (2000) Whales and dolphins (Mammalia, Cetacea) of the Cape Verde Islands, with special reference to the humpback whale *Megaptera novaeangliae* (Borowski, 1781). *Contrib To Zool* 69(3)197-211 2000 69: 15.
- Hernández-García V (1995) The diet of the swordfish *Xiphias gladius* Linnaeus, 1758, in the central east Atlantic, with emphasis on the role of cephalopods. *Fish Bull* 93: 403–411.
- Hinke JT, Kaplan IC, Aydin K, Watters GM, Olson RJ, Kitchell JF (2004) Visualizing the Food-Web Effects of Fishing for Tunas in the Pacific Ocean. *Ecol Soc* 9.
- Hobbs TR, O'Malley JP, Khouangsathiene S, Dubay CJ (2010) Comparison of lactate, base excess, bicarbonate, and pH as predictors of mortality after severe trauma in rhesus macaques (*Macaca mulatta*). *Comp Med* 60: 233–239.
- Hobday A, Smith ADM, Stobutzki IC, Bulman C, Daley R, Dambacher JM, Deng R a., Dowdney J, Fuller M, Furlani D, *et al.* (2011) Ecological risk assessment for the effects of fishing. *Fish Res* 108: 372–384.
- Holeton GF, Randall DJ (1967) The effect of hypoxia upon the partial pressure of gases in the blood and water afferent and efferent to the gills of rainbow trout. *J Exp Biol* 46: 317–327.
- Humborstad O-B, Davis MW, Lokkeborg S (2009) Reflex impairment as a measure of vitality and survival potential of Atlantic cod (*Gadus morhua*). *Fish Bull* 107: 395–402.
- ICCAT. Rec. 10-10 Recommendation By ICCAT To Establish Minimum Standards For Fishing Vessel Scientific Observer Programs.
- ICCAT. Rec. 11-10 Recommendation By Iccat On A Multi-Annual Conservation and Management Program For Bigeye And Yellowfin Tunas
- ICCAT. Rec. 14-01 Recommendation By ICCAT On A Multi-Annual Conservation and Management Program For Tropical Tunas

- ICCAT (2006-2015) *ICCAT Manual. International Commission for the Conservation of Atlantic Tuna. In: ICCAT Publications* [on-line]. Updated 2015.
- i-STAT Technical Bulletin (2013b) PCO₂ and Calculated Values for HCO₃, Base Excess and Anion Gap. Abbott Point of Care Inc., Abbott Park, IL, USA.
- Jaquemet S, Potier M, Ménard F (2011) Do drifting and anchored Fish Aggregating Devices (FADs) similarly influence tuna feeding habits? A case study from the western Indian Ocean. *Fish Res* 107: 283–290.
- Jenkins KLM, McBride RS (2009) Reproductive biology of wahoo, *Acanthocybium solandri*, from the Atlantic coast of Florida and the Bahamas. *Mar Freshw Res* 60: 893–897.
- Jennings S, Kaiser MJ (1998) The effects of fishing on marine ecosystems. *Adv Mar Biol* 34: 203–352.
- Jun Y, Prates M (2013) rbugs: Fusing R and OpenBugs and Beyond. R package version 0.5-9. <http://CRAN.R-project.org/package=rbugs>
- Kahraman AE, Göktürk D, Karakulak FS (2011) Age and growth of bullet tuna, *Auxis rochei* (Risso), from the Turkish Mediterranean coasts. *African J Biotechnol* 10: 3009–3013.
- Kalogirou S, Mittermayer F, Pihl L, Wennhage H (2012) Feeding ecology of indigenous and non-indigenous fish species within the family Sphyraenidae. *J Fish Biol* 80: 2528–2548.
- Kavanagh P, Newlands N, Christensen V, Pauly D (2004) Automated parameter optimization for Ecopath ecosystem models. *Ecol Modell* 172: 141–149.
- Lawson TA (1997) Estimation of Bycatch and Discards in Central and Western Pacific Tuna Fisheries: Preliminary Results. SPC.
- Lebourges-Dhaussy A, Marchal É, Menkes C, Champalbert G, Biessy B (2000) *Vinciguerria nimbaria* (micronekton), environment and tuna: their relationships in the Eastern Tropical Atlantic. *Oceanol Acta* 23: 515–528.
- Lessa R, Santana FM, Paglerani R (1999) Age, growth and stock structure of the oceanic whitetip shark, *Carcharhinus longimanus*, from the southwestern equatorial Atlantic. *Fish Res* 42: 21–30.
- Levin PS, Fogarty MJ, Murawski S a., Fluharty D (2009) Integrated ecosystem assessments: Developing the scientific basis for ecosystem-based management of the ocean. *PLoS Biol* 7.

- Lewison R, Soykan C, Cox T, Peckham H, Pilcher N, LeBoeuf N, McDonald S, Moore J, Safina C, Crowder L (2011) Ingredients for addressing the challenges of fisheries bycatch. *Bull Mar Sci* 87: 235–250.
- Libralato S, Pastres R, Pranovi F, Raicevich S, Granzotto A, Giovanardi O, Torricelli P (2002) Comparison between the energy flow networks of two habitats in the Venice Lagoon. *Mar Ecol* 23: 228–236.
- Libralato, S, et al. (2004) Mixed trophic impact and transfer efficiency as indicators of species' role and ecosystem state. *Biol Mar Med*. A 11.2: 255-264.
- Link JS, Brodziak JKT, Edwards SF, Overholtz WJ, Mountain D, Jossi JW, Smith TD, Fogarty MJ (2002) Marine ecosystem assessment in a fisheries management context. *Can J Fish Aquat Sci* 59: 1429–1440.
- Little, R. J., & Rubin, D. B. (2014). *Statistical analysis with missing data*. John Wiley & Sons.
- Lunn DJ, Thomas A, Best N, Spiegelhalter D (2000) WinBUGS – A Bayesian modelling framework: Concepts, structure, and extensibility. *Stat Comput* 10: 325–337.
- Lupes SC, Davis MW, Olla BL, Schreck CB (2006) Capture-related stressors impair immune system function in sablefish. *Trans Am Fish Soc* 135: 129–138.
- Lushchak VI, Bagnyukova T V (2006) Effects of different environmental oxygen levels on free radical processes in fish. *Comp Biochem Physiol B Biochem Mol Biol* 144: 283–9.
- Majkowski, J. (2007). *Global fishery resources of tuna and tuna-like species* (No. 483). Food & Agriculture Org..
- Marcalo A, Marques TA, Araujo J, Pousao-Ferraira P, Erzini K, Stratoudakis Y (2010) Fishing simulation experiments for predicting the effects of purse-seine capture on sardine (*Sardina pilchardus*). *ICES J Mar Sci* 67: 334–344.
- Marçalo A, Mateus L, Correia JHD, Serra P, Fryer R, Stratoudakis Y (2006) Sardine (*Sardina pilchardus*) stress reactions to purse seine fishing. *Mar Biol* 149: 1509–1518.
- Margalef, R (1968) "Diversity and stability: a practical proposal and a model of interdependence." In *Brookhaven symposia in biology*, vol. 22, pp. 25-37.
- Marsac F, Fonteneau A, Ménard F (2000) Drifting FADs used in tuna fisheries: an ecological trap? *Proc Ist Symp Tuna Fish FADs, Martinique, Oct 1999* 537–552.
- Marsac F, Fonteneau A, Ménard F, Hea L, Cedex M (n.d.) Drifting FADs used in tuna fisheries : an ecological trap? 34032–34032.

- McCarthy, Michael A. *Bayesian methods for ecology*. Cambridge University Press, 2007.
- Menard F, Fonteneau A, Gaertner D, Nordstrom V, Stequert B, Marchal É (2000) Exploitation of small tunas by a purse-seine fishery with fish aggregating devices and their feeding ecology in an eastern tropical Atlantic ecosystem. *ICES J Mar Sci* 57: 525–530.
- Ménard F, Lorrain A, Potier M, Marsac F (2007) Isotopic evidence of distinct feeding ecologies and movement patterns in two migratory predators (yellowfin tuna and swordfish) of the western Indian Ocean. *Mar Biol* 153: 141–152.
- Ménard F, Marchal E (2003) Foraging behaviour of tuna feeding on small schooling *Vinciguerria nimbaria* in the surface layer of the equatorial Atlantic Ocean. *Aquat Living Resour* 16: 231–238.
- Ménard F, Stéquert B, Rubin A, Herrera M, Marchal É (2000) Food consumption of tuna in the Equatorial Atlantic ocean: FAD-associated versus unassociated schools. *Aquac Res* 13: 233–240.
- Minami M, Lennert-Cody CE, Gao W, Román-Verdesoto M (2007) Modeling shark bycatch: The zero-inflated negative binomial regression model with smoothing. *Fish Res* 84: 210–221.
- Monin AJ, Javier A, Emmanuel C, Chavance P, Delgado de Molina A, Gaertner D, Murua H, Pianet R, Ruiz J (2008) By-catch and discards of the European purse-seine tuna fishery in the Indian Ocean. Estimation and characteristics for the 2003–2007 period. *IOTC-2008-WPEB* 26.
- Moore D (1967) Triggerfishes (Balistidae) of the western Atlantic. *Bull Mar Sci* 17: 689–722.
- Moreno G, Dagorn L, Sancho G, Itano D (2007a) Fish behaviour from fishers' knowledge: the case study of tropical tuna around drifting fish aggregating devices (DFADs). *Can J Fish Aquat Sci* 64: 1517–1528.
- Moreno G, Josse E, Brehmer P, Nøttestad L (2007b) Echotrace classification and spatial distribution of pelagic fish aggregations around drifting fish aggregating devices (DFAD). *Aquat Living Resour* 20: 343–356.
- Morissette L (2007) Complexity, Cost and Quality of Ecosystem Models and Their Impact on Resilience: A Comparative Analysis with Emphasis on Marine Mammals and the Gulf of Laurence. Ph.D. thesis, University of British Columbia, Vancouver, BC.
- Morissette L, Kaschner K, Gerber LR (2010) Ecosystem models clarify the trophic role of whales off Northwest Africa. *Mar Ecol Prog Ser* 404: 289–302.

- Muller RG, Murphy MD, Silva J De, Barbieri LR (2003) A stock assessment of yellowtail snapper, *Ocyurus chrysurus*, in the Southeast United States. *FWC-FMRI Rep IHR 2003-10 Florida*.
- Nilsson SG, Nilsson IN (1976) Numbers, food consumption, and fish predation by birds in Lake Möckeln, southern Sweden. *Ornis Scand* 7: 61–70.
- Notarbartolo-di-Sciara G (1987) Natural history of the rays of the genus *Mobula* in the Gulf of California. *Bull Mar Sci* 86: 45–66.
- Odum, EP (1969) The strategy of ecosystem development. *Sustainability: Sustainability*, 164, 58.
- Olla BL, Davis MW, Shreck CB (1995) Stress-induced impairment of predator evasion and non-predator mortality in Pacific salmon. *Aquac Res* 26: 393–398.
- Olson RJ, Watters GM (2003) A model of the pelagic ecosystem in the eastern tropical Pacific Ocean. *IATTC Bull* 22.
- Ortiz M, Arocha F (2004) Alternative error distribution models for standardization of catch rates of non-target species from a pelagic longline fishery: billfish species in the Venezuelan tuna longline fishery. *Fish Res* 70: 275–297.
- Opitz, S. (1996). *Trophic interactions in Caribbean coral reefs* (No. 1085). WorldFish.
- Oxenford HA, Hunte W (1999) Feeding habits of the dolphinfish (*Coryphaena hippurus*) in the eastern Caribbean. *Sci Mar* 63: 303–315.
- Pallarés P, Hallier JP (1997) Analyse du schéma d'échantillonnage multispécifique des thonidés tropicaux. *Rapport scientifique. IEO/ORSTOM, Programme, (95/37)*.
- Palomares ML, Pauly D (1989) A multiple regression model for predicting the food consumption of marine fish populations. *Aust J Mar Freshw Res* 40: 259–273.
- Patrício J, Ulanowicz R, Pardal M a., Marques JC (2006) Ascendency as ecological indicator for environmental quality assessment at the ecosystem level: A case study. *Hydrobiologia* 555: 19–30.
- Pauly D (1980) On the interrelationships between natural mortality, growth parameters, and mean environmental temperature in 175 fish stocks. *ICES J Mar Sci* 39: 175–192.
- Pauly D (1980) On the interrelationships between natural mortality, growth parameters, and mean environmental temperature in 175 fish stocks. *J Cons int Explor Mer* 39: 175–192.
- Pauly D (1998) Fishing down marine food webs. *Science (80)* 279: 860–863.

- Pauly D, Christensen V, Dalsgaard J, Froese R, Torres F (1998) Fishing down marine food webs. *Science* (80) 279: 860–863.
- Pauly D, Christensen V, Guénette S, Pitcher TJ, Sumaila UR, Walters CJ, Watson R, Zeller D (2002) Towards sustainability in world fisheries. *Nature* 418: 689–695.
- Pauly D, Christensen V, Walters C (2000) Ecopath, Ecosim, and Ecospace as tools for evaluating ecosystem impact of fisheries. *ICES J Mar Sci* 57: 697–706.
- Pauly D, Graham W, Libralato S, Morissette L, Deng Palomares ML (2009) Jellyfish in ecosystems, online databases, and ecosystem models. *Hydrobiologia* 616: 67–85.
- Pauly D, Trites A, Capuli E, Christensen V (1998) Diet composition and trophic levels of marine mammals. *ICES J Mar Sci* 55: 467–481.
- Petter Johnsen J, Eliassen S (2011) Solving complex fisheries management problems: What the EU can learn from the Nordic experiences of reduction of discards. *Mar Policy* 35: 130–139.
- Piercy AN, Carlson JK, Passerotti MS (2010) Age and growth of the great hammerhead shark, *Sphyrna mokarran*, in the north-western Atlantic Ocean and Gulf of Mexico. *Mar Freshw Res* 61: 992–998.
- Pikitch EK, Santora C, Babcock EA, Bakun A, Bonfil R, Conover DO, Dayton P, Doukakis P, Fluharty D, Heneman B, *et al.* (2004) Ecosystem-based fishery management. *Science* (80-) 305: 346–347.
- Pilling GM, Harley SJ, Nicol S, Williams P, Hampton J (2015) Can the tropical Western and Central Pacific tuna purse seine fishery contribute to Pacific Island population food security? *Food Secur* 7: 67–81.
- Plummer M, Best N, Cowles K, Vines K (2006). CODA: Convergence Diagnosis and Output Analysis for MCMC, R News, vol 6, 7-11
- Plummer M (2015). rjags: Bayesian Graphical Models using MCMC. R package version 3-15. <http://CRAN.R-project.org/package=rjags>
- Pollock KH, Pine WE (2007) The design and analysis of field studies to estimate catch-and-release mortality. *Fish Manag Ecol* 14: 123–130.
- Polovina JJ (1984) Model of a Coral Reef Ecosystem I. The Ecopath Model and its application to French Frigate Shoals. *Coral Reefs* 3: 1–11.
- Polovina JJ, Balazs GH, Howell E a, Parker DM, Seki MP, Dutton PH (2004) Forage and migration habitat of loggerhead (*Caretta caretta*) and olive ridley (*Lepidochelys olivacea*) sea turtles in the central North Pacific Ocean. *Fish Oceanogr* 13: 36–51.

- Potier M, Marsac F, Cherel Y, Lucas V, Sabatie R, Maury O, Menard F (2007) Forage fauna in the diet of three large pelagic fishes (lancetfish, swordfish and yellowfin tuna) in the western equatorial Indian Ocean. *Fish Res* 83: 60–72.
- Potier M, Marsac F, Cherel Y, Lucas V, Sabatie R, Maury O, Menard F (2007) Forage fauna in the diet of three large pelagic fishes (lancetfish, swordfish and yellowfin tuna) in the western equatorial Indian Ocean. *Fish Res* 83: 60–72.
- Punt AE, Smith DC, Tuck GN, Methot RD (2006) Including discard data in fisheries stock assessments: Two case studies from south-eastern Australia. *Fish Res* 79: 239–250.
- R Development Core Team (2008). R: A language and environment for statistical computing. R Foundation for Statistical Computing, Vienna, Austria. ISBN 3-900051-07-0, URL <http://www.R-project.org>.
- RStudio Team (2015). RStudio: Integrated Development for R. RStudio, Inc., Boston, MA URL <http://www.rstudio.com/>.
- Raby GD, Donaldson MR, Hinch SG, Patterson D a., Lotto AG, Robichaud D, English KK, Willmore WG, Farrell AP, Davis MW, *et al.* (2012) Validation of reflex indicators for measuring vitality and predicting the delayed mortality of wild coho salmon bycatch released from fishing gears. *J Appl Ecol* 49: 90–98.
- Rajruchithong S, Prajakjitt P, Siriraksophon S (2005) Bycatch from Tuna Purse Seine and Longline Fishing Gears in the Eastern Indian Ocean by MV SEAFDEC. *IOtC-2005-WPBy-07* 1–8.
- Ramirez CBG, Camila Posada (2014) First approach to the trophic ecology and diet of the rainbow runner, *Elagatis bipinnulata* (Quoy & Gaimard, 1825) (Pisces: Carangidae) in the central Colombian Caribbean. *Acta Biol Colomb* 19: 309–314.
- Rao, PSRS (2000) *Sampling methodologies*. Chapman & Hall/CRC.
- Restrepo V, Prince ED, Scott GP, Uozumi Y (2003) ICCAT stock assessments of Atlantic billfish. *Mar Freshw Res* 54: 361–367.
- Rochet M, Trenkel VM (2005) PERSPECTIVE / PERSPECTIVE Factors for the variability of discards : assumptions and field evidence. *Can J Fish Aquat Sci* 62: 224–235.
- Rochet M-J, Benoît E (2012) Fishing destabilizes the biomass flow in the marine size spectrum. *Proc Biol Sci* 279: 284–92.
- Rochet M-J, Trenkel VM (2005) Factors for the variability of discards: assumptions and field evidence. *Can J Fish Aquat Sci* 62: 224–235.

- Rubin D B, Little RJ (2002) Statistical analysis with missing data. *Hoboken, NJ: J Wiley & Sons*.
- Rummer JL (2007) Factors affecting catch and release (CAR) mortality in fish: Insight into CAR mortality in red snapper and the influence of catastrophic decompression. *Red Snapper Ecol Fish US Gulf Mex* 60: 123–144.
- Saillant E a., Renshaw MA, Cummings NJ, Gold JR (2012) Conservation genetics and management of yellowtail snapper, *Ocyurus chrysurus*, in the US Caribbean and South Florida. *Fish Manag Ecol* 19: 301–312.
- Santini F, Sorenson L, Alfaro ME (2013) A new multi-locus timescale reveals the evolutionary basis of diversity patterns in triggerfishes and filefishes (Balistidae, Monacanthidae; Tetraodontiformes). *Mol Phylogenet Evol* 69: 165–76.
- Schultz C (2001) Modélisation des flux trophiques dans une zone hauturière de l'Atlantique Equatorial Est: une application d'ECOPATH with ECOSIM
Modélisation des flux trophiques dans une zone hauturière de l'Atlantique Equatorial Est: une application d'ECOPATH with Ecosim.
- Schultz C, Menard F (2003) A model of trophic flows in a pelagic area of the Gulf of Guinea during the 1990's. *Collect Vol Sci Pap ICCAT* 55: 1940–1950.
- Schwalme K, Mackay WC (1985) The influence of exercise handling stress on blood lactate, acid-base, and plasma glucose status of northern pike (*Esox lucius* L.). *Can J Zool* 63: 1125–1129.
- Schwenke KL, Buckel J a. (2008) Age, growth, and reproduction of dolphinfish (*Coryphaena hippurus*) caught off the coast of North Carolina. *Fish Bull* 106: 82–92.
- Scott MD, Lennert-cody WHBCE, Schaefer KM (1992) Proceedings of the International Workshop of the Ecology and Fisheries for Tunas Associated with Floating Objects. *IATTC Spec Rep 11* 480 pg.
- Shannon LJ, Coll M, Neira S (2009) Exploring the dynamics of ecological indicators using food web models fitted to time series of abundance and catch data. *Ecol Indic* 9: 1078–1095.
- Shuford RL, Dean JM, Stequert B, Morize E (2007) Age and growth of yellowfin tuna in the Atlantic Ocean. *Collect Vol Sci Pap ICCAT* 60: 330–341.
- Skomal GB (2007) Evaluating the physiological and physical consequences of capture on post-release survivorship in large pelagic fishes. *Fish Manag Ecol* 14: 81–89.
- Stephen J a., Harris PJ (2010) Commercial catch composition with discard and immediate release mortality proportions off the southeastern coast of the United States. *Fish Res* 103: 18–24.

- Stevens J (2000) The effects of fishing on sharks, rays, and chimaeras (chondrichthyans), and the implications for marine ecosystems. *ICES J Mar Sci* 57: 476–494.
- Stillwell CE, Kohler NE (1982) Food, feeding habits, and estimates of daily ration of the shortfin mako (*Isurus oxyrinchus*) in the Northwest Atlantic. *Can J Fish Aquat Sci* 39: 407–414.
- Stoner AW (2012) Evaluating vitality and predicting mortality in spot prawn, *Pandalus platyceros*, using reflex behaviors. *Fish Res* 119-120: 108–114.
- Stoot LJ, Cairns NA, Cull F, Taylor JJ, Jeffrey JD, Morin F, Mandelman JW, Clark TD, Cooke SJ (2014) Use of portable blood physiology point-of-care devices for basic and applied research on vertebrates: a review. *Conserv Physiol* 2: cou011.
- Stratoudakis Y, Fryer RJ, Cook RM, Pierce GJ (1999) Fish discarded from Scottish demersal vessels: Estimators of total discards and annual estimates for targeted gadoids. *ICES J Mar Sci* 56: 592–605.
- Sturtz S, Ligges U, Gelman, A (2005) R2WinBUGS: A package for running WinBUGS from R. *Journal of Statistical Software*, 12(3), 1-16.
- Suski CD, Cooke SJ, Danylchuk AJ, O'Connor CM, Gravel MA, Redpath T, Hanson KC, Gingerich AJ, Murchie KJ, Danylchuk SE, *et al.* (2007) Physiological disturbance and recovery dynamics of bonefish (*Albula vulpes*), a tropical marine fish, in response to variable exercise and exposure to air. *Comp Biochem Physiol - A Mol Integr Physiol* 148: 664–673.
- Suter JM, Suter JM (2003) The potential use of time-area closures to reduce catches of bigeye tuna. *Fish* 49–61.
- Tamsett D, Janacek G (1999) Sampling trips for measuring discards in commercial fishing based on multilevel modelling of measurements in the North Sea from NE England. *Fish Res* 42.
- Taquet M, Dagorn L, Gaertner J, Girard C, Aumerruddy R, Sancho G, Itano D (2007) Behavior of dolphinfish (*Coryphaena hippurus*) around drifting FADs as observed from automated acoustic receivers. *Aquat Living Resour* 20: 323–330.
- Taquet M, Sancho G, Dagorn L, Gaertner J, Itano D, Aumeeruddy R, Wendling B, Peignon C (2008) Characterizing fish communities associated with drifting fish aggregating devices (FADs) in the Western Indian Ocean using underwater visual surveys. *Aquat Living Resour* 341: 331–341.
- Taylor P, Barton BA, Schreck CB, Sigismondi LA (1986) Multiple acute disturbances evoke cumulative physiological stress responses in juvenile Chinook salmon. *Trans Am Fish Soc* 115: 245–251.

- Thomas (1994). BUGS: a statistical modelling package. RTA/BCS Modular Languages Newsletter (Volume 2) pp. 36--38
- Torres-Irineo E, Amade JM, Gaertner D, Delgado de Molina A, Murua H, Chavance P, Javier A, Ruiz J, Lezam-Ochoa N (2014) Bycatch species composition over time by tuna purse-seine fishery in the eastern tropical Atlantic Ocean. *Biodivers Conserv* 23: 1157–1173.
- Torres-Irineo E, Gaertner D, de Molina AD, Ariz J (2011) Effects of time-area closure on tropical tuna purse-seine fleet dynamics through some fishery indicators. *Aquat Living Resour* 24: 337–350.
- Trites AW, Christensen V, Pauly D (1997) Competition between fisheries and marine mammals for prey and primary production in the Pacific Ocean. *J Northwest Atl Fish Sci* 22: 173–187.
- Tudela S, Coll M, Palomera I (2005) Developing an operational reference framework for fisheries management on the basis of a two-dimensional index of ecosystem impact. *ICES J Mar Sci* 62: 585–591.
- Ulanowicz RE (1980) An hypothesis on the development of natural communities. *J Theor Biol* 85: 223–245.
- Ulanowicz, R. E. (2012). *Growth and development: ecosystems phenomenology*. Springer Science & Business Media.
- Valle M, Legault CM, Ortiz M (2001) A stock assessment for gray triggerfish (*Balistes capriscus*) in the Gulf of Mexico. In: Sustainable Fisheries Division Contribution SFD-00/01-124.
- Valle S, Barros N, Wanless RM (n.d.) Status and Trends of the Seabirds Breeding at Tinhosa Grande Island, São Tomé E Príncipe. Birdlife International.
- Vasconcellos M, Mackinson S, Sloman K, Pauly D (1997) The stability of trophic mass-balance models of marine ecosystems: A comparative analysis. *Ecol Modell* 100: 125–134.
- Vasconcellos M, Watson R (2004) Mass-balance models of oceanic systems in the Atlantic. In: West African Marine Ecosystems: Models and Fisheries Impacts. Fisheries Centre Research Report (12)7. pp 171–214.
- Vasilakopoulos P, Pavlidis M, Tserpes G (2010) On the diet and reproduction of the oilfish *Ruvettus pretiosus* (Perciformes: Gempylidae) in the eastern Mediterranean. *J Mar Biol Assoc United Kingdom* 91: 873–881.
- Vaske Júnior T, Vooren CM, Lessa RP (2003) Feeding habits of yellowfin tuna (*Thunnus albacares*), and wahoo (*Acanthocybium solandri*) in the Saint Peter and Saint Paul Archipelago, Brazil. *B Inst Pesca* 29: 173–181.

- Venables, WN, Ripley BD (2002) *Modern applied statistics with S*. Fourth Edition. Springer, New York. ISBN 0-387-95457-0
- Vose FE, Nelson WG (1994) Gray triggerfish (*Balistes capriscus* Gmenlin) feeding from artificial and natural substrate in shallow Atlantic waters of Florida. *Bull Mar Sci* 55: 1316–1323.
- Weir CR (2010) A review of cetacean occurrence in West African waters from the Gulf of Guinea to Angola. *Mamm Rev* 40: 2–39.
- Weir CR (2011) Distribution and seasonality of cetaceans in tropical waters between Angola and the Gulf of Guinea. *African J Mar Sci* 33: 1–15.
- Wendelaar Bonga SE (1997) The stress response in fish. *Physiol Rev* 77.
- Wiafe G, Yaqub HB, Mensah MA, Frid CLJ (2008) Impact of climate change on long-term zooplankton biomass in the upwelling region of the Gulf of Guinea. *ICES J Mar Sci* 65: 318–324.
- Wigley SE, Rago PJ, Sosebee KA, Palka DL (2007) The analytic component to the standardized bycatch reporting methodology omnibus amendment: Sampling design, and estimation of precision and accuracy (2nd Edition). US Dep. Commer., Northeast Fish. Sci. Cent. Ref. Doc. 07-09; 156 p.
- Winter A, Jiao Y, Browder JA (2011) Modeling low rates of seabird bycatch in the U.S. Atlantic longline fishery modeling low rates of seabird bycatch in the U.S. Atlantic longline fishery. *Waterbirds* 34: 289–303.
- Wintner SP, Cliff G (1999) Age and growth determination of the white shark, *Carcharodon carcharias*, from the east coast of South Africa. *Fish Bull* 97: 153–169.
- Wintner SP, Dudley SFJ (2000) Age and growth estimates for the tiger shark, *Galeocerdo cuvier*, from the east coast of South Africa. *Mar Freshw Res* 51: 43.
- Wu RSS (2002) Hypoxia: from molecular responses to ecosystem responses. *Mar Pollut Bull* 45: 35–45.
- Su Y, Yajima M (2015) R2jags: Using R to Run 'JAGS'. R package version 0.5-6. <http://CRAN.R-project.org/package=R2jags>
- Zhou S, Smith ADM, Punt AE, Richardson AJ, Gibbs M, Fulton EA, Pascoe S, Bulman C, Bayliss P, Sainsbury K (2010) Ecosystem-based fisheries management requires a change to the selective fishing philosophy. *Proc Natl Acad Sci U S A* 107: 9485–9.
- Zhu G, Xu L, Zhou Y, Song L, Dai X (2009) Length-Weight Relationships for Bigeye Tuna (*Thunnus Obesus*), Yellowfin Tuna (*Thunnus Albacares*) and Albacore (*Thunnus Alalunga*) (Perciformes: Scombrinae) in the Atlantic, Indian and Eastern Pacific Oceans. *Collect Vol Sci Pap ICCAT* 65: 717–724.